



Programming Guide

VLT[®] AutomationDrive FC 360



Contents

1 Introduction	3
1.1 How to Read This Programming Guide	3
1.2 Definitions	4
1.3 Electrical Wiring - Control Cables	7
2 Safety	11
2.1 Safety Symbols	11
2.2 Qualified Personnel	11
2.3 Safety Precautions	11
3 Programming	13
3.1 Local Control Panel Operations	13
3.2 Basic Programming	21
4 Parameter Descriptions	24
4.1 Parameters: 0-** Operation and Display	24
4.2 Parameters: 1-** Load and Motor	33
4.3 Parameters: 2-** Brakes	45
4.4 Parameters: 3-** Reference/Ramps	48
4.5 Parameters: 4-** Limits/Warnings	54
4.6 Parameters: 5-** Digital In/Out	57
4.7 Parameters: 6-** Analog In/Out	71
4.8 Parameters: 7-** Controllers	74
4.9 Parameters: 8-** Communications and Options	79
4.10 Parameters: 9-** PROFIdrive	84
4.11 Parameters: 12-** Ethernet	90
4.12 Parameters: 13-** Smart Logic Control	93
4.13 Parameters: 14-** Special Functions	100
4.14 Parameters: 15-** Drive Information	106
4.15 Parameters: 16-** Data Readouts	108
4.16 Parameters: 17-** Feedback Options	112
4.17 Parameters: 18-** Data Readouts 2	112
4.18 Parameters: 21-** Ext. Closed Loop	113
4.19 Parameters: 22-** Application Functions	115
4.20 Parameters: 30-** Special Features	117
4.21 Parameters: 32-** Motion Control Basic Settings	117
4.22 Parameters: 33-** Motion Control Adv. Settings	117
4.23 Parameters: 34-** Motion Control Data Readouts	118
4.24 Parameters: 37-** Application Settings	120

5 Parameter Lists	125
5.1 Introduction	125
5.2 Parameter Lists	128
6 Troubleshooting	149
6.1 Warnings and Alarms	149
6.1.1 Alarms	149
6.1.2 Warnings	149
Index	159

1 Introduction

1.1 How to Read This Programming Guide

1.1.1 Purpose of the Manual

This programming guide provides information about controlling the frequency converter, parameter access, programming, and troubleshooting. The programming guide is intended for use by qualified personnel who are familiar with VLT® AutomationDrive FC 360. Read the instructions before programming and follow the procedures in this manual. VLT® is a registered trademark.

1.1.2 Additional Resources

Additional resources include:

- VLT® AutomationDrive FC 360 Quick Guide provide the necessary information for getting the frequency converter up and running.
- VLT® AutomationDrive FC 360 Design Guide provides detailed technical information about the frequency converter and customer design and applications.

Contact the local Danfoss supplier or go to www.danfoss.com/fc360 to download the documentations.

1.1.3 Document and Software Version

This manual is regularly reviewed and updated. All suggestions for improvement are welcome. Table 1.1 shows the document version and the corresponding software version.

Edition	Remarks	Software version
MG06C7	Update due to new software version release.	1.7x

Table 1.1 Document and Software Version

°C	Degrees Celsius
°F	Fahrenheit
AC	Alternating current
AEO	Automatic energy optimization
ACP	Application control processor
AWG	American wire gauge
AMA	Automatic motor adaptation
DC	Direct current
EEPROM	Electrically erasable programmable read-only memory
EMC	Electromagnetic compatibility
EMI	Electromagnetic interference
ESD	Electrostatic discharge
ETR	Electronic thermal relay
f _{M,N}	Nominal motor frequency
FC	Frequency converter
IGBT	Insulated-gate bipolar transistor
IP	Ingress protection
I _{LIM}	Current limit
I _{INV}	Rated inverter output current
I _{M,N}	Nominal motor current
I _{VLT,MAX}	Maximum output current
I _{VLT,N}	Rated output current supplied by the frequency converter
L _d	Motor d-axis inductance
L _q	Motor q-axis inductance
LCP	Local control panel
LED	Light-emitting diode
MCP	Motor control processor
N.A.	Not applicable
NEMA	National Electrical Manufacturers Association
P _{M,N}	Nominal motor power
PCB	Printed circuit board
PE	Protective earth
PELV	Protective extra low voltage
PWM	Pulse width modulation
R _s	Stator resistance
Regen	Regenerative terminals
RPM	Revolutions per minute
RFI	Radio frequency interference
SCR	Silicon controlled rectifier
SMPS	Switch mode power supply
T _{LIM}	Torque limit
U _{M,N}	Nominal motor voltage
X _h	Motor main reactance

Table 1.2 Abbreviations

1.1.4 Approvals and Certifications

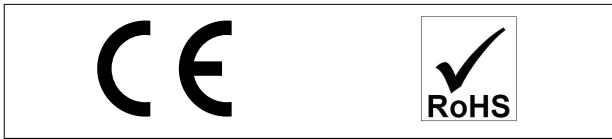

1.2 Definitions

1.2.1 Frequency Converter

Coast

The motor shaft is in free mode. No torque on the motor.

$I_{VLT,MAX}$

Maximum output current.

$I_{VLT,N}$

Rated output current supplied by the frequency converter.

$U_{VLT,MAX}$

Maximum output voltage.

1.2.2 Input

Control commands

Start and stop the connected motor with the LCP and digital inputs.

Functions are divided into 2 groups.

Functions in group 1 have higher priority than functions in group 2.

Group 1	Coast stop, reset and coast stop, quick stop, DC braking, stop, and [OFF].
Group 2	Start, latched start, start reversing, jog, freeze output, and [Hand On].

Table 1.3 Function Groups

1.2.3 Motor

Motor running

Torque generated on the output shaft and speed from 0 RPM to maximum speed on the motor.

f_{JOG}

Motor frequency when the jog function is activated (via digital terminals or bus).

f_M

Motor frequency.

f_{MAX}

Maximum motor frequency.

f_{MIN}

Minimum motor frequency.

$f_{M,N}$

Rated motor frequency (nameplate data).

I_M

Motor current (actual).

$I_{M,N}$

Nominal motor current (nameplate data).

$n_{M,N}$

Nominal motor speed (nameplate data).

n_s

Synchronous motor speed.

$$n_s = \frac{2 \times \text{Parameter 1-23} \times 60 \text{ s}}{\text{Parameter 1-39}}$$

n_{slip}

Motor slip.

$P_{M,N}$

Rated motor power (nameplate data in kW or hp).

$T_{M,N}$

Rated torque (motor).

U_M

Instantaneous motor voltage.

$U_{M,N}$

Rated motor voltage (nameplate data).

Break-away torque

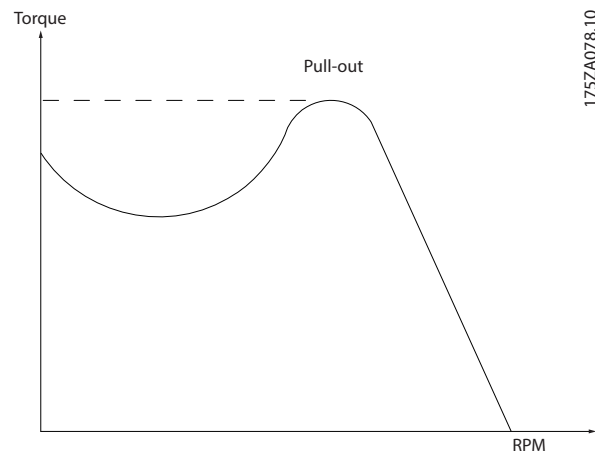

175ZA078.10

Illustration 1.1 Break-away Torque

η_{VLT}

The efficiency of the frequency converter is defined as the ratio between the power output and the power input.

Start-disable command

A start-disable command belonging to the control commands in group 1. See Table 1.3 for more details.

Stop command

A stop command belonging to the control commands in group 1. See Table 1.3 for more details.

1.2.4 References

Analog reference

A signal transmitted to the analog inputs 53 or 54 can be voltage or current.

Binary reference

A signal transmitted via the serial communication port.

Preset reference

A defined preset reference to be set from -100% to +100% of the reference range. Selection of 8 preset references via the digital terminals. Selection of 4 preset references via the bus.

Pulse reference

A pulse frequency signal transmitted to the digital inputs (terminal 29 or 33).

Ref_{MAX}

Determines the relationship between the reference input at 100% full scale value (typically 10 V, 20 mA) and the resulting reference. The maximum reference value is set in *parameter 3-03 Maximum Reference*.

Ref_{MIN}

Determines the relationship between the reference input at 0% value (typically 0 V, 0 mA, 4 mA) and the resulting reference. The minimum reference value is set in *parameter 3-02 Minimum Reference*.

1.2.5 Miscellaneous

Analog inputs

The analog inputs are used for controlling various functions of the frequency converter.

There are 2 types of analog inputs:

- Current input: 0–20 mA and 4–20 mA.
- Voltage input: 0–10 V DC.

Analog outputs

The analog outputs can supply a signal of 0–20 mA, or 4–20 mA.

Automatic motor adaptation, AMA

The AMA algorithm determines the electrical parameters for the connected motor at standstill.

Brake resistor

The brake resistor is a module capable of absorbing the brake power generated in regenerative braking. This regenerative brake power increases the DC-link voltage and a brake chopper ensures that the power is transmitted to the brake resistor.

CT characteristics

Constant torque characteristics used for all applications such as conveyor belts, displacement pumps, and cranes.

Digital inputs

The digital inputs can be used for controlling various functions of the frequency converter.

Digital outputs

The frequency converter features 2 solid-state outputs that can supply a 24 V DC (maximum 40 mA) signal.

ETR

Electronic thermal relay is a thermal load calculation based on present load and time. Its purpose is to estimate the motor temperature.

FC standard bus

Includes RS485 bus with FC protocol or MC protocol. See *parameter 8-30 Protocol*.

Initializing

If initializing is carried out (*parameter 14-22 Operation Mode* or 2 finger reset), the frequency converter returns to the default setting.

Intermittent duty cycle

An intermittent duty rating refers to a sequence of duty cycles. Each cycle consists of an on-load and an off-load period. The operation can be either periodic duty or non-periodic duty.

LCP

The local control panel makes up a complete interface for control and programming of the frequency converter. The LCP is detachable. With the installation kit option, the LCP can be installed up to 3 m (9.8 ft) from the frequency converter in a front panel.

GLCP

The graphic local control panel (LCP 102) interface for control and programming of the frequency converter. The display is graphic and the panel is used to show process values. The GLCP has storing and copy functions.

NLCP

The numerical local control panel (LCP 21) interface for control and programming of the frequency converter. The display is numerical and the panel is used to show process values. The NLCP has storing and copy functions.

lsb

Least significant bit.

msb

Most significant bit.

MCM

Short for mille circular mil, an American measuring unit for cable cross-section. 1 MCM = 0.5067 mm².

On-line/off-line parameters

Changes to on-line parameters are activated immediately after the data value is changed. To activate changes to off-line parameters, press [OK].

Process PID

The PID control maintains speed, pressure, and temperature by adjusting the output frequency to match the varying load.

PCD

Process control data.

Power cycle

Switch off the mains until the display (LCP) is dark, then turn power on again.

Power factor

The power factor is the relation between I_1 and I_{RMS} .

$$\text{Power factor} = \frac{\sqrt{3} \times U \times I_1 \cos\phi}{\sqrt{3} \times U \times I_{RMS}}$$

For VLT® AutomationDrive FC 360 frequency converters, $\cos\phi_1 = 1$, therefore:

$$\text{Power factor} = \frac{I_1 \times \cos\phi_1}{I_{RMS}} = \frac{I_1}{I_{RMS}}$$

The power factor indicates to which extent the frequency converter imposes a load on the mains supply.

The lower the power factor, the higher the I_{RMS} for the same kW performance.

$$I_{RMS} = \sqrt{I_1^2 + I_5^2 + I_7^2 + \dots + I_n^2}$$

In addition, a high-power factor indicates that the different harmonic currents are low.

The built-in DC coils produce a high-power factor, minimizing the imposed load on the mains supply.

Pulse input/incremental encoder

An external, digital pulse transmitter used for feeding back information on motor speed. The encoder is used in applications where great accuracy in speed control is required.

RCD

Residual current device.

Set-up

Save parameter settings in 2 set-ups. Change between the 2 parameter set-ups and edit 1 set-up while another set-up is active.

SFAVM

Acronym describing the switching pattern stator flux-oriented asynchronous vector modulation.

Slip compensation

The frequency converter compensates for the motor slip by giving the frequency a supplement that follows the measured motor load, keeping the motor speed almost constant.

Smart logic control (SLC)

The SLC is a sequence of user-defined actions executed when the smart logic controller evaluates the associated user-defined events as true (*parameter group 13-*** Smart Logic Control*).

STW

Status word.

THD

Total harmonic distortion states the total contribution of harmonic distortion.

Thermistor

A temperature-dependent resistor placed where the temperature is monitored (frequency converter or motor).

Trip

A state entered in fault situations, for example if the frequency converter is subject to overvoltage or when it is protecting the motor, process, or mechanism. Restart is prevented until the cause of the fault has disappeared, and the trip state is canceled by activating reset or, sometimes, by being programmed to reset automatically. Do not use trip for personal safety.

Trip lock

Trip lock is a state entered in fault situations when the frequency converter is protecting itself and requiring physical intervention. An example causing a trip lock is the frequency converter being subject to a short circuit on the output. A locked trip can only be canceled by cutting off mains, removing the cause of the fault, and reconnecting the frequency converter. Restart is prevented until the trip state is canceled by activating reset or, sometimes, by being programmed to reset automatically. Do not use trip lock for personal safety.

VT characteristics

Variable torque characteristics used for pumps and fans.

VVC+

If compared with standard voltage/frequency ratio control, voltage vector control (VVC+) improves the dynamics and stability, both when the speed reference is changed and in relation to the load torque.

60° AVM

Refers to the switching pattern *60° asynchronous vector modulation*.

1.3 Electrical Wiring - Control Cables

1.3.1 Overview

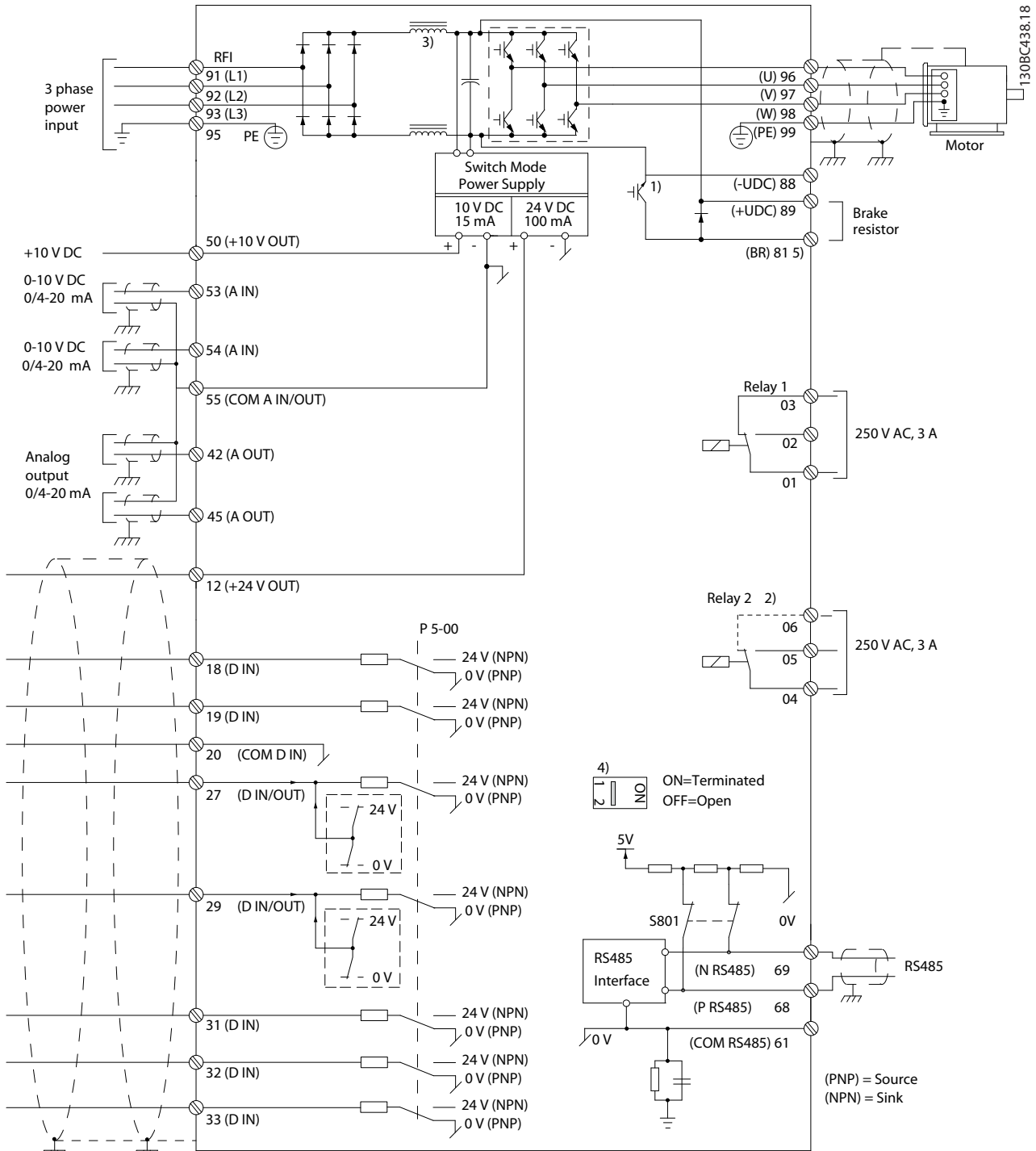

Illustration 1.2 Basic Wiring Schematic Drawing

A=Analog, D=Digital

1) Built-in brake chopper available from J1-J5.

2) Relay 2 is 2-pole for J1-J3 and 3-pole for J4-J7. Relay 2 of J4-J7 with terminals 4, 5, and 6 has same NO/NC logic as relay 1. Relays are pluggable in J1-J5 and fixed in J6-J7.

1

- 3) Single DC choke in J1–J5; Dual DC choke in J6–J7.
- 4) Switch S801 (bus terminal) can be used to enable termination on the RS485 port (terminals 68 and 69).
- 5) No BR for J6–J7.

In rare cases, long control cables and analog signals could result in 50/60 Hz ground loops due to noise from mains supply cables. If this occurs, break the shield or insert a 100 nF capacitor between shield and chassis.

The digital and analog inputs and outputs must be connected separately to the common inputs (terminal 20 and 55) of the frequency converter to avoid ground currents from both groups to affect other groups. For example, switching on the digital input could disturb the analog input signal.

Input polarity of control terminals

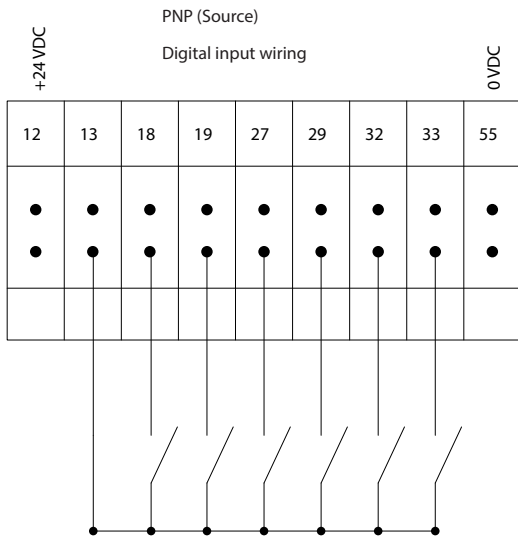

Illustration 1.3 PNP (Source)

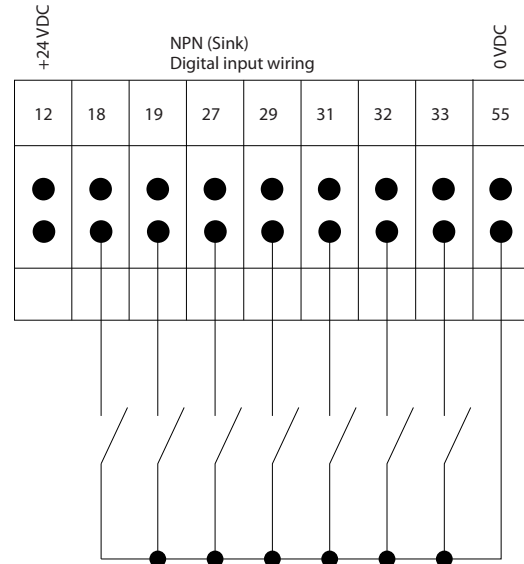

Illustration 1.4 NPN (Sink)

NOTICE

Control cables must be shielded/armored.

See the section *Using Shielded Control Cables* in the *design guide* for the correct termination of control cables.

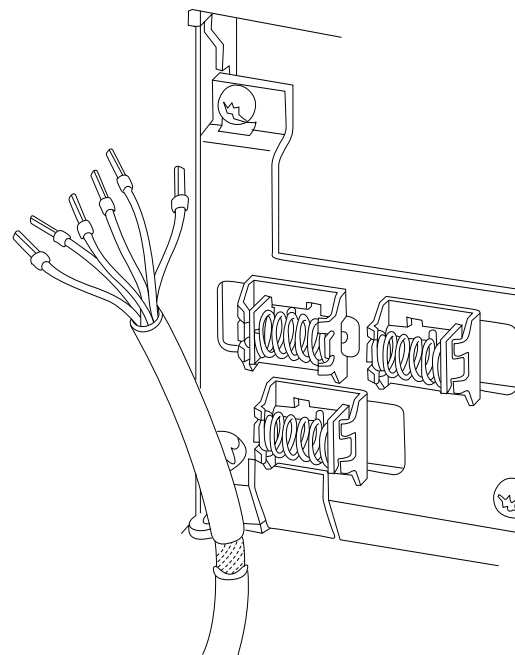

Illustration 1.5 Grounding of Shielded/Armored Control Cables

1.3.2 Start/Stop

Terminal 18 = Parameter 5-10 Terminal 18 Digital Input [8] Start.

Terminal 27 = Parameter 5-12 Terminal 27 Digital Input [0] No operation (Default coast inverse).

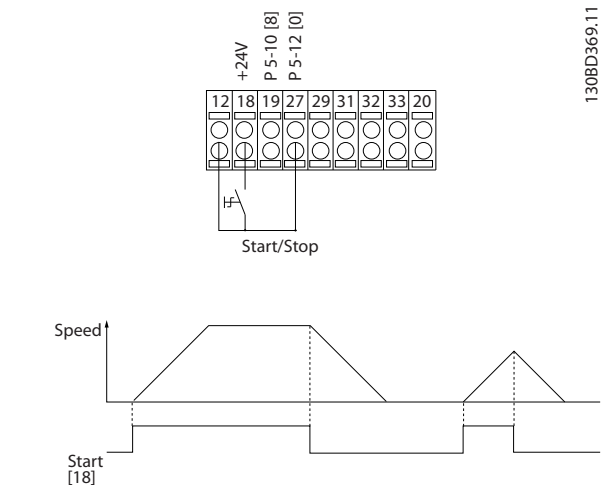

Illustration 1.6 Start/Stop

1.3.3 Latched Start/Stop Inverse

Terminal 18 = Parameter 5-10 Terminal 18 Digital Input [9] Latched start.

Terminal 27 = Parameter 5-12 Terminal 27 Digital Input [6] Stop inverse.

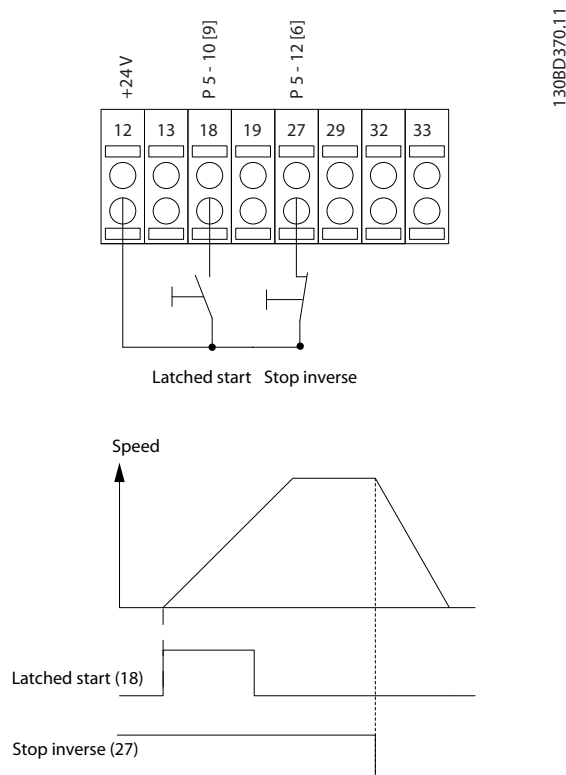

Illustration 1.7 Latched Start/Stop Inverse

1.3.4 Speed Up/Down

Terminals 29/32=Speed up/down

Terminal 18 = *Parameter 5-10 Terminal 18 Digital Input [8] Start* (default).

Terminal 27 = *Parameter 5-12 Terminal 27 Digital Input [19] Freeze reference*.

Terminal 29 = *Parameter 5-13 Terminal 29 Digital Input [21] Speed up*.

Terminal 32 = *Parameter 5-14 Terminal 32 Digital Input [22] Speed down*.

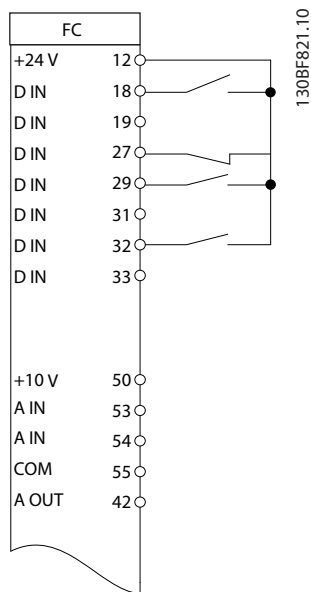

Illustration 1.8 Speed Up/Down

1.3.5 Potentiometer Reference

Voltage reference via a potentiometer

Reference source 1=[1] *Analog input 53* (default).

Terminal 53, low voltage=0 V.

Terminal 53, high voltage=10 V.

Terminal 53, low ref./feedback=0.

Terminal 53, high ref./feedback=50.

Parameter 6-19 Terminal 53 mode=[1] Voltage.

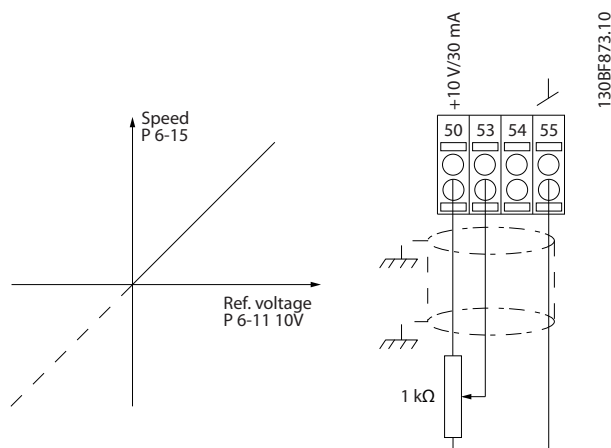

Illustration 1.9 Potentiometer Reference

2 Safety

2.1 Safety Symbols

The following symbols are used in this guide:

⚠ WARNING

Indicates a potentially hazardous situation that could result in death or serious injury.

⚠ CAUTION

Indicates a potentially hazardous situation that could result in minor or moderate injury. It can also be used to alert against unsafe practices.

NOTICE

Indicates important information, including situations that can result in damage to equipment or property.

2.2 Qualified Personnel

Correct and reliable transport, storage, installation, operation, and maintenance are required for the trouble-free and safe operation of the frequency converter. Only qualified personnel are allowed to install and operate this equipment.

Qualified personnel are defined as trained staff, who are authorized to install, commission, and maintain equipment, systems, and circuits in accordance with pertinent laws and regulations. Also, the qualified personnel must be familiar with the instructions and safety measures described in this manual.

2.3 Safety Precautions

⚠ WARNING

HIGH VOLTAGE

Frequency converters contain high voltage when connected to AC mains input, DC supply, or load sharing. Failure to perform installation, start-up, and maintenance by qualified personnel can result in death or serious injury.

- Only qualified personnel must perform installation, start-up, and maintenance.
- Before performing any service or repair work, use an appropriate voltage measuring device to make sure that there is no remaining voltage on the drive.

⚠ WARNING

UNINTENDED START

When the frequency converter is connected to AC mains, DC supply, or load sharing, the motor may start at any time. Unintended start during programming, service, or repair work can result in death, serious injury, or property damage. The motor can start via an external switch, a serial bus command, an input reference signal from the LCP, or after a cleared fault condition.

To prevent unintended motor start:

- Disconnect the frequency converter from the mains.
- Press [Off/Reset] on the LCP before programming parameters.
- Completely wire and assemble the frequency converter, motor, and any driven equipment before connecting the frequency converter to AC mains, DC supply, or load sharing.

⚠ WARNING

DISCHARGE TIME

The frequency converter contains DC-link capacitors, which can remain charged even when the frequency converter is not powered. High voltage can be present even when the warning LED indicator lights are off. Failure to wait the specified time after power has been removed before performing service or repair work can result in death or serious injury.

- Stop the motor.
- Disconnect AC mains and remote DC-link power supplies, including battery back-ups, UPS, and DC-link connections to other frequency converters.
- Disconnect or lock PM motor.
- Wait for the capacitors to discharge fully. The minimum duration of waiting time is specified in *Table 2.1* and is also visible on the product label on top of the frequency converter.
- Before performing any service or repair work, use an appropriate voltage measuring device to make sure that the capacitors are fully discharged.

Voltage [V]	Power range [kW (hp)]	Minimum waiting time (minutes)
380–480	0.37–7.5 kW (0.5–10 hp)	4
380–480	11–75 kW (15–100 hp)	15

Table 2.1 Discharge Time

⚠ WARNING**LEAKAGE CURRENT HAZARD**

Leakage currents exceed 3.5 mA. Failure to ground the frequency converter properly can result in death or serious injury.

- Ensure the correct grounding of the equipment by a certified electrical installer.

⚠ WARNING**EQUIPMENT HAZARD**

Contact with rotating shafts and electrical equipment can result in death or serious injury.

- Ensure that only trained and qualified personnel perform installation, start-up, and maintenance.
- Ensure that electrical work conforms to national and local electrical codes.
- Follow the procedures in this guide.

⚠ CAUTION**INTERNAL FAILURE HAZARD**

An internal failure in the frequency converter can result in serious injury when the frequency converter is not properly closed.

- Ensure that all safety covers are in place and securely fastened before applying power.

NOTICE**HIGH ALTITUDES**

For installation at altitudes above 2000 m (6562 ft), contact Danfoss regarding PELV.

NOTICE**USE ON ISOLATED MAINS**

For details about the use of the frequency converter on isolated mains, refer to the section *RFI Switch* in the *design guide*.

Follow the recommendations regarding the installation on IT mains. Use relevant monitoring devices for IT mains to avoid damage.

3 Programming

3.1 Local Control Panel Operations

VLT® AutomationDrive FC 360 supports numerical local control panel (NLCP) LCP 21, graphic local control panel (GLCP) LCP 102, and blind cover. This chapter describes the operations with LCP 21 and LCP 102.

NOTICE

The frequency converter can also be programmed from the MCT-10 Set-up Software on PC via RS485 com-port. This software can be ordered using code number 130B1000 or downloaded from the Danfoss website: drives.danfoss.com/downloads/pctools/#/.

3.1.1 Numerical Local Control Panel

The numerical local control panel LCP 21 is divided into 4 functional sections.

- A. Numeric display.
- B. Menu key.
- C. Navigation keys and indicator lights (LEDs).
- D. Operation keys and indicator lights (LEDs).

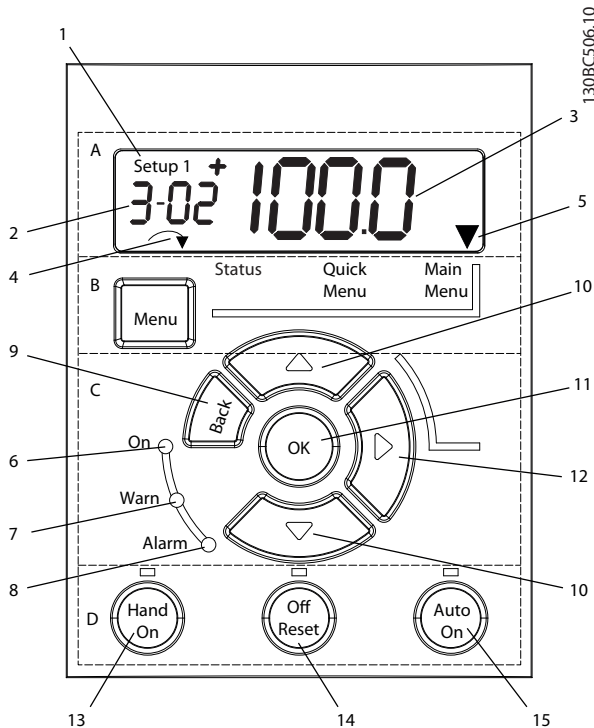

Illustration 3.1 View of the LCP 21

A. Numeric display

The LCD display is backlit with 1 numeric line. All data is shown in the LCP.

1	The set-up number shows the active set-up and the edit set-up. If the same set-up acts as both active and edit set-up, only that set-up number is shown (factory setting). When active and edit set-ups differ, both numbers are shown in the display (set-up 12). The number flashing indicates the edit set-up.
2	Parameter number.
3	Parameter value.
4	Motor direction is shown at the bottom left of the display. A small arrow indicates the direction.
5	The triangle indicates whether the LCP is in Status, Quick Menu, or Main Menu.

Table 3.1 Legend to Illustration 3.1, Section A



Illustration 3.2 Display Information

B. Menu key

To select between Status, Quick Menu, or Main Menu, press [Menu].

C. Indicator lights (LEDs) and navigation keys

	Indicator	Light	Function
6	On	Green	ON turns on when the frequency converter receives power from the mains voltage, a DC bus terminal, or a 24 V external supply.
7	Warn	Yellow	When warning conditions are met, the yellow WARN LED turns on, and text appears in the display area identifying the problem.
8	Alarm	Red	A fault condition causes the red alarm LED to flash and an alarm text is shown.

Table 3.2 Legend to Illustration 3.1, Indicator Lights (LEDs)

	Key	Function
9	[Back]	For moving to the previous step or layer in the navigation structure.
10	[▲] [▼]	For switching between parameter groups, parameters, and within parameters, or increasing/decreasing parameter values. Arrows can also be used for setting local reference.
11	[OK]	Press to access parameter groups or to enable a selection.
12	[▶]	Press to move from left to right within the parameter value to change each digit individually.

Table 3.3 Legend to *Illustration 3.1, Navigation Keys*

D. Operation keys and indicator lights (LEDs)

	Key	Function
13	Hand On	Starts the frequency converter in local control. <ul style="list-style-type: none"> An external stop signal by control input or serial communication overrides the local hand on.
14	Off/Reset	Stops the motor but does not remove power to the frequency converter, or resets the frequency converter manually after a fault has been cleared. If in alarm mode, the alarm is reset if the alarm condition is removed.
15	Auto On	Puts the system in remote operational mode. <ul style="list-style-type: none"> Responds to an external start command by control terminals or bus communication.

Table 3.4 Legend to *Illustration 3.1, Section D*

⚠ WARNING

HIGH VOLTAGE

Touching the frequency converter after pressing the [Off/Reset] key is still dangerous, because the key does not disconnect the frequency converter from the mains.

- Disconnect the frequency converter from the mains and wait for the frequency converter to fully discharge. See the discharge time in *Table 2.1*.

3.1.2 The Right-key Function on NLCP

Press [▶] to edit any of the 4 digits on the display individually. When pressing [▶] once, the cursor moves to the first digit and the digit starts flashing as shown in *Illustration 3.3*. Press the [▲] [▼] to change the value. Pressing [▶] does not change the value of the digits or move the decimal point.

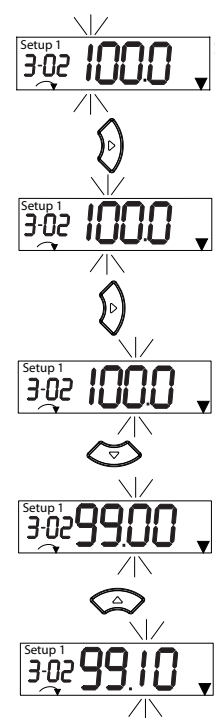

Illustration 3.3 Right-key Function

[▶] can also be used for moving between parameter groups. When in *Main Menu*, press [▶] to move to the first parameter in the next parameter group (for example, move from *parameter 0-03 Regional Settings [0] International* to *parameter 1-00 Configuration Mode [0] Open loop*).

3.1.3 Quick Menu on NLCP

The *Quick Menu* gives easy access to the most frequently used parameters.

- To enter *Quick Menu*, press [Menu] until the indicator in display is placed above *Quick Menu*.
- Press [▲] [▼] to select either QM1 or QM2, then press [OK].
- Press [▲] [▼] to browse through the parameters in *Quick Menu*.
- Press [OK] to select a parameter.
- Press [▲] [▼] to change the value of a parameter setting.
- Press [OK] to accept the change.
- To exit, press either [Back] twice (or 3 times if in QM2 and QM3) to enter *Status*, or press [Menu] once to enter *Main Menu*.

3.1.4 Status Menu on NLCP

After power-up, Status Menu is active. Press [Menu] to toggle between *Status*, *Quick Menu*, and *Main Menu*.

[▲] and [▼] toggle between the options in each menu.

The display indicates the status mode with a small arrow above *Status*.

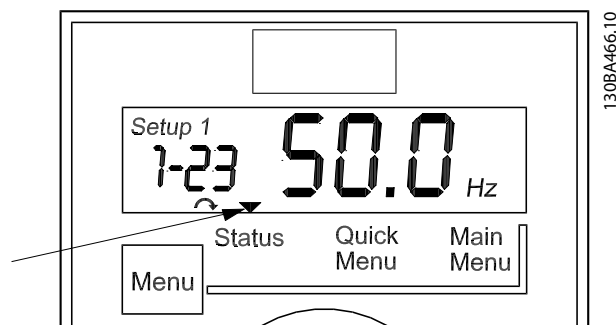

Illustration 3.5 Indicating Status Mode

The following 8 parameters can be accessed from NLCP status menu in auto-on mode:

- Parameter 16-02 Reference [%].
- Parameter 16-09 Custom Readout.
- Parameter 16-10 Power [kW].
- Parameter 16-13 Frequency.
- Parameter 16-14 Motor current.
- Parameter 16-16 Torque [Nm].
- Parameter 16-30 DC Link Voltage.
- Parameter 16-52 Feedback[Unit].

The following 6 parameters can be accessed from NLCP status menu in [Hand On] mode:

- Parameter 16-09 Custom Readout.
- Parameter 16-10 Power [kW].
- Parameter 16-13 Frequency.
- Parameter 16-14 Motor current.
- Parameter 16-16 Torque [Nm].
- Parameter 16-30 DC Link Voltage.

3.1.5 Main Menu on NLCP

The *Main Menu* gives access to all parameters.

1. To enter *Main Menu*, press [Menu] until the indicator in the display is placed above *Main Menu*.
2. [▲] [▼]: Browse through the parameter groups.
3. Press [OK] to select a parameter group.
4. [▲] [▼]: Browse through the parameters in the specific group.
5. Press [OK] to select the parameter.
6. [▶] and [▲] [▼]: Set/change the parameter value.
7. Press [OK] to accept the value.
8. To exit, press either [Back] twice (or 3 times for array parameters) to enter *Main Menu*, or press [Menu] once to enter *Status*.

See *Illustration 3.6*, *Illustration 3.7*, and *Illustration 3.8* for the principles of changing the value of continuous, enumerated, and array parameters, respectively. The actions in the illustrations are described in *Table 3.5*, *Table 3.6*, and *Table 3.7*.

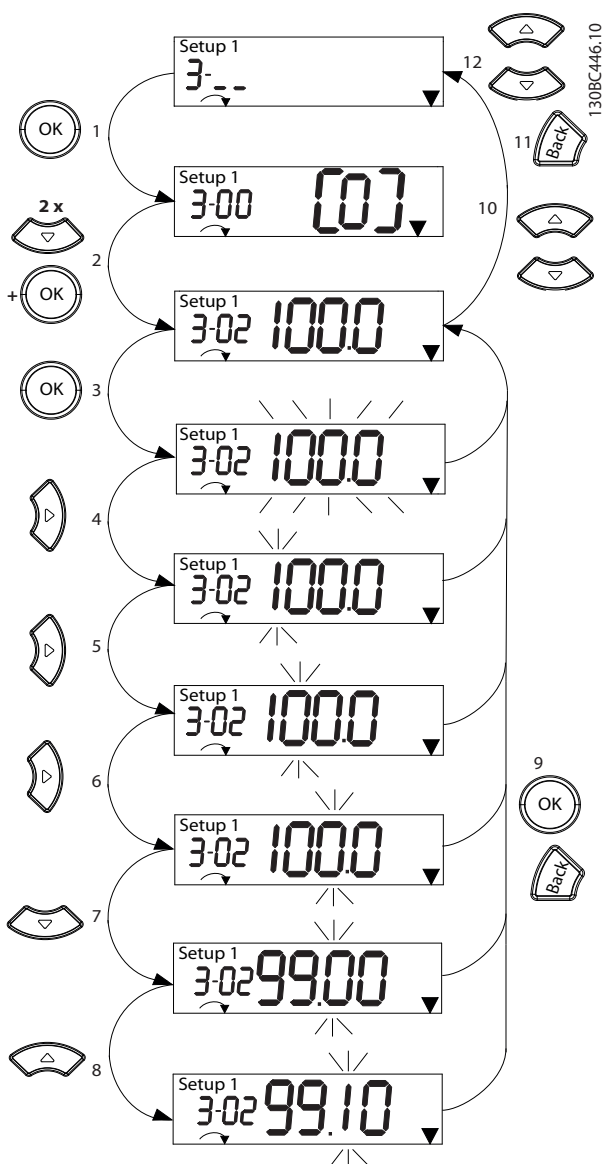

Illustration 3.6 Main Menu Interactions - Continuous Parameters

1	[OK]: The first parameter in the group is shown.
2	Press [▼] repeatedly to move down to the parameter.
3	Press [OK] to start editing.
4	[▶]: First digit flashing (can be edited).
5	[▶]: Second digit flashing (can be edited).
6	[▶]: Third digit flashing (can be edited).
7	[▼]: Decreases the parameter value, the decimal point changes automatically.
8	[▲]: Increases the parameter value.
9	[Back]: Cancel changes, return to 2. [OK]: Accept changes, return to 2.
10	[▲][▼]: Select parameter within the group.
11	[Back]: Removes the value and shows the parameter group.
12	[▲][▼]: Select group.

Table 3.5 Changing Values in Continuous Parameters

For enumerated parameters, the interaction is similar, but the parameter value is shown in brackets because of the LCP 21 digits limitation (4 large digits), and the enum can be greater than 99. When the enum value is greater than 99, the LCP 21 can only show the first part of the bracket.

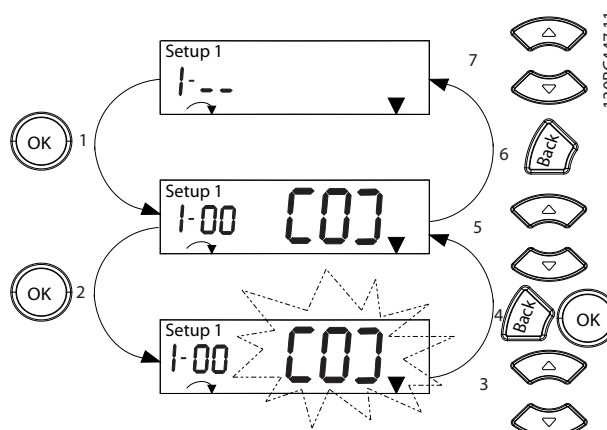

Illustration 3.7 Main Menu Interactions - Enumerated Parameters

1	[OK]: The first parameter in the group is shown.
2	Press [OK] to start editing.
3	[▲][▼]: Change parameter value (flashing).
4	Press [Back] to cancel changes or [OK] to accept changes (return to screen 2).
5	[▲][▼]: Select a parameter within the group.
6	[Back]: Removes the value and shows the parameter group.
7	[▲][▼]: Select a group.

Table 3.6 Changing Values in Enumerated Parameters

Array parameters function as follows:

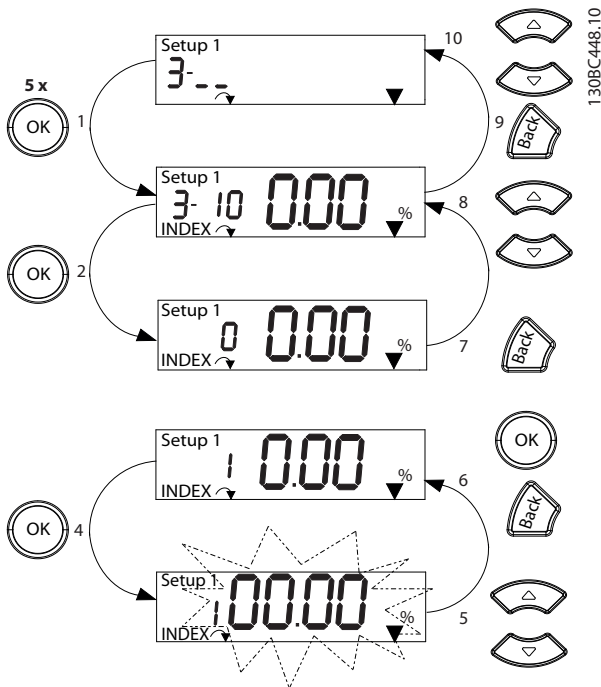

Illustration 3.8 Main Menu Interactions - Array Parameters

1	[OK]: Shows parameter numbers and the value in the first index.
2	[OK]: Index can be selected.
3	[▲][▼]: Select index.
4	[OK]: Value can be edited.
5	[▲][▼]: Change parameter value (flashing).
6	[Back]: Cancels changes. [OK]: Accepts changes.
7	[Back]: Cancels editing index, a new parameter can be selected.
8	[▲][▼]: Select parameter within the group.
9	[Back]: Removes parameter index value and shows the parameter group.
10	[▲][▼]: Select group.

Table 3.7 Changing Values in Array Parameters

3.1.6 Graphical Local Control Panel

The graphical local control panel LCP 102 has a larger display area, which shows more information than LCP 21. LCP 102 supports English, Chinese, and Portuguese displays.

The GLCP is divided into 4 functional groups (see Illustration 3.9).

- A. Display area.
- B. Display menu keys.
- C. Navigation keys and indicator lights (LEDs).
- D. Operation keys and reset.

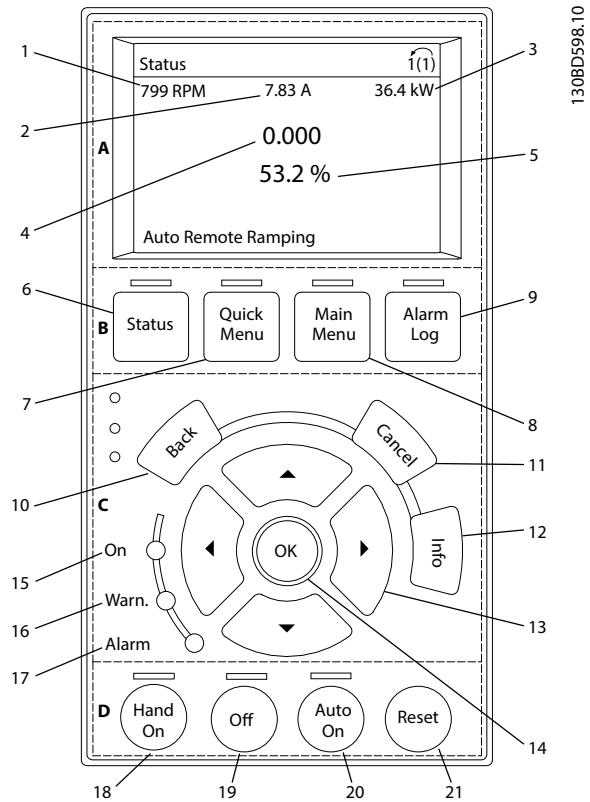

Illustration 3.9 Graphic Local Control Panel (GLCP)

A. Display area

The display area is activated when the frequency converter receives power from the mains voltage or a DC bus terminal.

The information shown on the LCP can be customized for user applications. Select options in the *Quick Menu Q3-13 Display Settings*.

Display	Parameter number	Default setting
1	0-20	[1602] Reference [%]
2	0-21	[1614] Motor Current
3	0-22	[1610] Power [kW]
4	0-23	[1613] Frequency
5	0-24	[1502] kWh Counter

Table 3.8 Legend to Illustration 3.9, Display Area

B. Display menu keys

Menu keys are used for menu access for parameter set-up, toggling through status display modes during normal operation, and viewing fault log data.

	Key	Function
6	Status	Shows operational information.
7	Quick Menu	Allows access to programming parameters for initial set-up instructions and many detailed application instructions.
8	Main Menu	Allows access to all programming parameters.
9	Alarm Log	Shows a list of current warnings, the last 10 alarms, and the maintenance log.

Table 3.9 Legend to *Illustration 3.9, Display Menu Keys*

C. Navigation keys and indicator lights (LEDs)

Navigation keys are used for programming functions and moving the display cursor. The navigation keys also provide speed control in local operation. There are also 3 frequency converter status indicator lights in this area.

	Key	Function
10	Back	Reverts to the previous step or list in the menu structure.
11	Cancel	Cancels the last change or command as long as the display mode has not changed.
12	Info	Press for a definition of the function being shown.
13	Navigation keys	To move between items in the menu, use the 4 navigation keys.
14	OK	Press to access parameter groups or to enable a selection.

Table 3.10 Legend to *Illustration 3.9, Navigation Keys*

	Indicator	Light	Function
15	On	Green	ON turns on when the frequency converter receives power from the mains voltage or a DC bus terminal.
16	Warn	Yellow	When warning conditions are met, the yellow WARN LED turns on, and text appears in the display area identifying the problem.
17	Alarm	Red	A fault condition causes the red alarm LED to flash, and an alarm text is shown.

Table 3.11 Legend to *Illustration 3.9, Indicator Lights (LEDs)*

D. Operation keys and reset

Operation keys are at the bottom of the LCP.

	Key	Function
18	Hand On	Starts the frequency converter in hand-on mode. <ul style="list-style-type: none"> An external stop signal by control input or serial communication overrides the local hand on.
19	Off	Stops the motor but does not remove power to the frequency converter.
20	Auto On	Puts the system in remote operational mode. <ul style="list-style-type: none"> Responds to an external start command by control terminals or serial communication.
21	Reset	Resets the frequency converter manually after a fault has been cleared.

Table 3.12 Legend to *Illustration 3.9, Operation Keys and Reset*

NOTICE

To adjust the display contrast, press [Status] and the [▲]/[▼] keys.

3.1.7 Changing Parameter Settings with GLCP

Access and change parameter settings from the *Quick Menu* or from the *Main Menu*. The *Quick Menu* only gives access to a limited number of parameters.

1. Press [Quick Menu] or [Main Menu] on the LCP.
2. Press [▲] [▼] to browse through the parameter groups, press [OK] to select a parameter group.
3. Press [▲] [▼] to browse through the parameters, press [OK] to select a parameter.
4. Press [▲] [▼] to change the value of a parameter setting.
5. Press [◀] [▶] to shift digit when a decimal parameter is in the editing state.
6. Press [OK] to accept the change.
7. Press either [Back] twice to enter Status, or press [Main Menu] once to enter the Main Menu.

View changes

Quick Menu Q5 - Changes Made lists all parameters changed from default settings.

- The list only shows parameters, which have been changed in the current edit set-up.
- Parameters which have been reset to default values are not listed.
- The message *Empty* indicates that no parameters have been changed.

3.1.8 Mounting the GLCP

Use the GLCP adapter (ordering number: 132B0281) and a cable to connect the LCP 102 to frequency converter, as shown in *Illustration 3.10*.

3

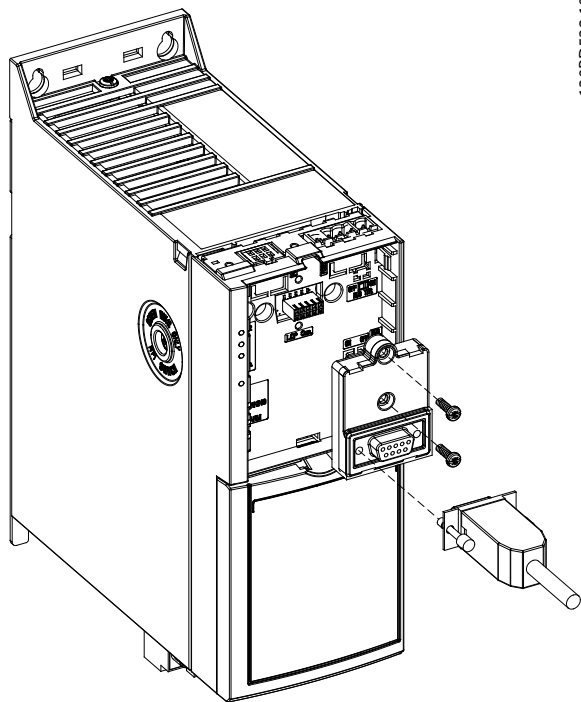

Illustration 3.10 GLCP Adapter and Connecting Cable

3.1.9 Backing Up/Downloading Parameters with LCP

Establishing the correct programming for applications often requires setting functions in several related parameters. Parameter details are provided in *chapter 4 Parameter Descriptions*.

Programming data is stored internally in the frequency converter.

- For back-up, upload data into the LCP memory.
- To download data to another frequency converter, connect the LCP to that unit and download the stored settings.
- Restoring factory default settings does not change data stored in the LCP memory.

Back-up/download process

1. Press [Off] on GLCP or [Off Reset] on NLCP to stop the motor before uploading or downloading data.
2. Press [Main Menu] *parameter 0-50 LCP Copy* and press [OK].
3. Select [1] *All to LCP* to upload data to the LCP, or select [2] *All from LCP* to download data from the LCP, or select [3] *Size indep. from LCP* to download motor size independent parameters from LCP.
4. Press [OK]. A progress bar shows the uploading or downloading progress.
5. Press [Hand On] or [Auto On] to return to normal operation.

3.1.10 Restoring Default Settings with LCP

NOTICE

Risk of losing programming, motor data, localization, and monitoring records by restoration of default settings. To provide a back-up, upload data to the LCP before initialization.

Restoring the default parameter settings is done by initialization of the frequency converter. Initialization is carried out through *parameter 14-22 Operation Mode* (recommended) or manually. Initialization does not reset the settings for *parameter 1-06 Clockwise Direction* and *parameter 0-03 Regional Settings*.

- Initialization using *parameter 14-22 Operation Mode* does not reset frequency converter settings, such as operating hours, serial communication selections, fault log, alarm log, and other monitoring functions.
- Manual initialization erases all motor, programming, localization, and monitoring data, and restores factory default settings.

Recommended initialization procedure, via *parameter 14-22 Operation Mode*

1. Select *parameter 14-22 Operation Mode* and press [OK].
2. Select [2] *Initialisation* and press [OK].
3. Remove power to the unit and wait until the display turns off.
4. Apply power to the unit.

Default parameter settings are restored during start-up. This may take slightly longer than normal.

5. *Alarm 80, Drive initialized to default value* is shown.
6. Press [Reset] to return to operating mode.

Manual initialization procedure

1. Remove power to the unit and wait until the display turns off.
2. Press and hold [Status], [Main Menu], and [OK] at the same time on the GLCP, or press [Menu] and [OK] at the same time on the NLCP while applying power to the unit (approximately 5 s or until a click is heard and the fan starts).

Factory default parameter settings are restored during start-up. This may take slightly longer than normal.

Manual initialization does not reset the following frequency converter information:

- *Parameter 0-03 Regional Settings*
- *Parameter 1-06 Clockwise Direction*
- *Parameter 15-00 Operating hours*
- *Parameter 15-03 Power Up's*
- *Parameter 15-04 Over Temp's*
- *Parameter 15-05 Over Volt's*
- *Parameter 15-30 Alarm Log: Error Code*

3.2 Basic Programming

3.2.1 Asynchronous Motor Set-up

Enter the following motor data in the listed order. Find the information on the motor nameplate.

1. *Parameter 1-20 Motor Power.*
2. *Parameter 1-22 Motor Voltage.*
3. *Parameter 1-23 Motor Frequency.*
4. *Parameter 1-24 Motor Current.*
5. *Parameter 1-25 Motor Nominal Speed.*

For optimum performance in VVC⁺ mode, extra motor data is required to set up the following parameters.

6. *Parameter 1-30 Stator Resistance (Rs).*
7. *Parameter 1-31 Rotor Resistance (Rr).*
8. *Parameter 1-33 Stator Leakage Reactance (X1).*
9. *Parameter 1-35 Main Reactance (Xh).*

The data is found in the motor datasheet (this data is typically not available on the motor nameplate). Run a complete AMA using *parameter 1-29 Automatic Motor Adaption (AMA) [1] Enable Complete AMA* or enter the parameters manually.

Application-specific adjustment when running VVC⁺

VVC⁺ is the most robust control mode. In most situations, it provides optimum performance without further adjustments. Run a complete AMA for best performance.

3.2.2 PM Motor Set-up in VVC⁺

Initial programming steps

1. Set *parameter 1-10 Motor Construction* to the following options to activate PM motor operation:
 - 1a *[1] PM, non salient SPM*
 - 1b *[3] PM, salient IPM*
2. Select *[0] Open Loop* in *parameter 1-00 Configuration Mode*.

NOTICE

Encoder feedback is not supported for PM motors.

Programming motor data

When the initial programming steps are completed, the PM motor-related parameters in *parameter groups 1-2* Motor Data, 1-3* Adv. Motor Data, and 1-4* Adv. Motor Data II* are active.

The information is on the motor nameplate and in the motor datasheet.

Program the following parameters in the listed order:

1. *Parameter 1-24 Motor Current.*
2. *Parameter 1-26 Motor Cont. Rated Torque.*
3. *Parameter 1-25 Motor Nominal Speed.*
4. *Parameter 1-39 Motor Poles.*
5. *Parameter 1-40 Back EMF at 1000 RPM.*
6. *Parameter 1-42 Motor Cable Length.*

Run a complete AMA using *parameter 1-29 Automatic Motor Adaption (AMA)* and select *[1] Enable Complete AMA*. If a complete AMA is not performed successfully, configure the following parameters manually.

1. *Parameter 1-30 Stator Resistance (Rs).*
Enter phase common stator winding resistance (Rs). If only phase-to-phase data is available, divide the phase-to-phase value by 2 to achieve the phase value.
It is also possible to measure the value with an ohmmeter, which also takes the resistance of the cable into account. Divide the measured value by 2 and enter the result.
2. *Parameter 1-37 d-axis Inductance (Ld).*
Enter direct axis inductance of the PM motor. If only phase-to-phase data is available, divide the phase-to-phase value by 2 to achieve the phase value.
It is also possible to measure the value with an inductance meter, which also takes the inductance of the cable into account. Divide the measured value by 2 and enter the result.
3. *Parameter 1-38 q-axis Inductance (Lq).*

This parameter is active only when *parameter 1-10 Motor Construction* is set to [3] PM, salient IPM.

Enter the quadrature axis inductance of the PM motor. If only phase-to-phase data is available, divide the phase-to-phase value by 2 to achieve the phase value.

It is also possible to measure the value with an inductance meter, which also takes the inductance of the cable into account. Make 1 rotation of the motor's rotor and find the maximum phase-to-phase inductance value. Divide the value by 2 and enter the result.

4. *Parameter 1-44 d-axis Inductance Sat. (LdSat).*
This parameter is active only when *parameter 1-10 Motor Construction* is set to [3] PM, salient IPM.

This parameter corresponds to the saturation inductance of d-axis. The default value is the value set in *parameter 1-37 d-axis Inductance (Ld)*. Do not change the default value in most cases. If the motor supplier provides the saturation curve, enter the d-axis inductance value, which is 100% of the nominal current.

5. *Parameter 1-45 q-axis Inductance Sat. (LqSat).*
This parameter is active only when *parameter 1-10 Motor Construction* is set to [3] PM, salient IPM.

This parameter corresponds to the saturation inductance of q-axis. The default value is the value set in *parameter 1-38 q-axis Inductance (Lq)*. In most cases, do not change the default. If the motor supplier provides the saturation curve, enter the q-axis inductance value, which is 100% of the nominal current.

Test motor operation

1. Start the motor at low speed (100–200 RPM). If the motor does not run, check installation, general programming, and motor data.
2. Check if the start function in *parameter 1-70 Start Mode* fits the application requirements.

Rotor detection

This function is the recommended selection for applications where the motor starts from standstill, for example pumps or conveyors. For some motors, a sound is heard when the frequency converter performs the rotor detection. This sound does not harm the motor. Adjust the value in *parameter 1-46 Position Detection Gain* for different motors. If the frequency converter fails to start, or an overcurrent alarm occurs when the frequency converter starts, check if the rotor is blocked or not. If the rotor is not blocked, set *parameter 1-70 Start Mode* to [1] Parking and try again.

Parking

This function is the recommended option for applications where the motor is rotating at low speed, for example windmilling in fan applications. *Parameter 2-06 Parking Current* and *parameter 2-07 Parking Time* are adjustable. Increase the factory setting of these parameters for applications with high inertia.

Start the motor at nominal speed. If the application does not run well, check the VVC+ PM settings. *Table 3.13* shows recommendations in different applications.

Application	Settings
Low inertia applications $I_{Load}^1/I_{Motor}^2 < 5$	<ul style="list-style-type: none"> • Increase the value for <i>parameter 1-17 Voltage filter time const.</i> by factor 5 to 10. • Reduce the value for <i>parameter 1-14 Damping Gain</i>. • Reduce the value (<100%) for <i>parameter 1-66 Min. Current at Low Speed</i>.
Medium inertia applications $50 > I_{Load}/I_{Motor} > 5$	Keep calculated values.
High inertia applications $I_{Load}/I_{Motor} > 50$	Increase the values for <i>parameter 1-14 Damping Gain</i> , <i>parameter 1-15 Low Speed Filter Time Const.</i> , and <i>parameter 1-16 High Speed Filter Time Const.</i>
High load at low speed <30% (rated speed)	Decrease <i>parameter 1-17 Voltage filter time const.</i> Decrease <i>parameter 1-66 Min. Current at Low Speed</i> (>100% for longer time can overheat the motor).

Table 3.13 Recommendations in Different Applications

- 1) I_{Load} = The inertia of load.
- 2) I_{Motor} = The inertia of motor.

If the motor starts oscillating at a certain speed, increase *parameter 1-14 Damping Gain*. Increase the value in small steps.

Adjust the starting torque in *parameter 1-66 Min. Current at Low Speed*. 100% provides nominal torque as starting torque.

3.2.3 Automatic Motor Adaptation (AMA)

It is highly recommended to run AMA because it measures the electrical characteristics of the motor to optimize compatibility between the frequency converter and the motor under VVC⁺ mode.

- The frequency converter builds a mathematical model of the motor for regulating output motor current, thus enhancing motor performance.
- Some motors are unable to run the complete version of the test. In that case, select *Enable reduced AMA* (not for PM).
- If warnings or alarms occur, see *chapter 6.1.3 Warning/alarm Messages*.
- Run this procedure on a cold motor for best results.

To run AMA using the numeric LCP

1. By default parameter setting, connect terminals 12 and 27 before running AMA.
2. Enter the *Main Menu*.
3. Go to *parameter group 1-*** Load and Motor*.
4. Press [OK].
5. Set motor parameters using nameplate data for *parameter group 1-2* Motor Data*.
6. Set *parameter 1-39 Motor Poles* for IM and PM.
7. Set *parameter 1-40 Back EMF at 1000 RPM* for PM.
8. Set motor cable length in *parameter 1-42 Motor Cable Length*.
9. Go to *parameter 1-29 Automatic Motor Adaptation (AMA)*.
10. Press [OK].
11. Select *[1] Enable complete AMA*.
12. Press [OK].
13. Press [Hand On] to activate AMA.
14. The test runs automatically and indicates when it is complete.

Depending on the power size, the AMA takes 3–10 minutes to complete.

NOTICE

The AMA function does not cause the motor to run, and it does not harm the motor.

4 Parameter Descriptions

4.1 Parameters: 0-** Operation and Display

Parameters related to the fundamental functions of the frequency converter, function of the LCP keys, and configuration of the LCP display.

4

4.1.1 0-0* Basic Settings

0-01 Language		
Option:	Function:	
[0] *	English	
[10]	Chinese	
[28]	Portuguese	

0-03 Regional Settings		
Option:	Function:	
		NOTICE This parameter cannot be adjusted while the motor is running.
[0] *	International	Activate <i>parameter 1-20 Motor Power [kW]</i> for setting the motor power in kW and set the default value of <i>parameter 1-23 Motor Frequency</i> to 50 Hz.
[1]	US	Activate <i>parameter 1-20 Motor Power [kW]</i> for setting the motor power in hp and set the default value of <i>parameter 1-23 Motor Frequency</i> to 60 Hz.

0-04 Operating State at Power-up (Hand)		
Option:	Function:	
		Select the operating mode upon reconnection of the frequency converter to mains voltage after power down in hand-on mode.
[0]	Resume	Restart the frequency converter, maintaining the start/stop settings (applied by [Hand On/Off]) selected before the power-down of the frequency converter.
[1] *	Forced stop, ref=old	Restart the frequency converter with a saved local reference after mains voltage reappears and after pressing [Hand On].
[2]	Forced stop, ref=0	Reset the local reference to 0 upon restarting the frequency converter.

0-06 GridType		
Option:	Function:	
		Select the grid type of the supply voltage/frequency. NOTICE Not all options are supported in all power sizes. IT grid is a supply mains, where the neutral point of secondary side of the transformer is not connected to ground. Delta is a supply mains where the secondary part of the transformer is delta-connected and 1 phase is connected to ground.
[10]	380-440V/50Hz/IT-grid	
[11]	380-440V/50Hz/Delta	
[12]	380-440V/50Hz	
[20]	440-480V/50Hz/IT-grid	
[21]	440-480V/50Hz/Delta	
[22]	440-480V/50Hz	
[110]	380-440V/60Hz/IT-grid	
[111]	380-440V/60Hz/Delta	
[112]	380-440V/60Hz	
[120]	440-480V/60Hz/IT-grid	
[121]	440-480V/60Hz/Delta	
[122]	440-480V/60Hz	

0-07 Auto DC Braking		
Option:	Function:	
		Protective function against overvoltage at coast in IT grid environment. This parameter is active only when [1] On is selected in this parameter.
[0]	Off	This function is not active.
[1] *	On	This function is active.

4.1.2 0-1* Set-up Operations

Define and control the individual parameter set-ups. The frequency converter has 2 parameter set-ups that can be programmed independently of each other. This makes the frequency converter flexible and able to solve advanced control functionality problems, often saving the cost of external control equipment. For example, the 2 set-ups can be used to program the frequency converter to operate according to 1 control scheme in 1 set-up (for example, motor 1 for horizontal movement) and another control scheme in another set-up (for example, motor 2 for vertical movement). Alternatively, they can be used by an OEM machine builder to program all their factory-fitted frequency converters for different machine types within a range to have the same parameters and then during production/commissioning simply select a specific set-up, depending on which machine the frequency converter is installed on.

The active set-up (that is, the set-up in which the frequency converter is operating) can be selected in *parameter 0-10 Active Set-up* and is shown in the LCP. By selecting [9] *Multi set-up*, it is possible to switch between set-ups with the frequency converter running or stopped, via digital input or serial communication commands. If it is necessary to change set-ups while running, ensure that *parameter 0-12 Link Setups* is set as required. Use *parameter 0-11 Programming Set-up* to edit parameters within any of the set-ups while continuing the operation of the frequency converter in its active set-up, which can be a different set-up to that being edited. Use *parameter 0-51 Set-up Copy* to copy parameter settings between the set-ups to enable quicker commissioning if similar parameter settings are required in different set-ups.

0-10 Active Set-up		
Option:	Function:	
		Select the set-up in which the frequency converter is to operate. Select <i>parameter 0-51 Set-up Copy</i> to copy a set-up to 1 or all set-ups. To avoid conflicting settings of the same parameter within 2 different set-ups, link the set-ups together in <i>parameter 0-12 Link Setups</i> . Stop the frequency converter before switching between set-ups where the parameters marked <i>Not changeable during operation</i> have different values. Parameters which are <i>Not changeable during operation</i> are marked FALSE in the parameter lists in <i>chapter 5 Parameter Lists</i> .
[1] *	Set-up 1	Set-up 1 is active.
[2]	Set-up 2	Set-up 2 is active.
[9]	Multi Set-up	This option is used for remote set-up selections via digital inputs and the serial communication port. This set-up uses the settings from <i>parameter 0-12 Link Setups</i> .

0-11 Programming Set-up		
Option:	Function:	
		Select the set-up to be programmed during operation; either the active set-up or the inactive set-up. The set-up number being edited flashes in the LCP.
[1]	Set-up 1	[1] <i>Set-up 1</i> to [2] <i>Set-up 2</i> can be edited freely during operation, independently of the active set-up.
[2]	Set-up 2	
[9] *	Active Set-up	The set-up in which the frequency converter is operating can also be edited during operation.

0-12 Link Setups		
Option:	Function:	
		The link ensures synchronizing of the <i>Not changeable during operation</i> parameter values enabling shift from 1 set-up to another during operation. If the set-ups are not linked, a change between them is not possible while the motor is running. Thus the set-up change does not occur until the motor is coasted.
[0]	Not linked	Leave parameters unchanged in both set-ups and cannot be changed while the motor is running.
[20] *	Linked	Copy <i>Not changeable during operation</i> parameters from 1 set-up to the other, so they are identical in both set-ups.

0-14 Readout: Edit Set-ups / Channel		
Range:	Function:	
0* [-2147483647 - 2147483647]		View the setting of <i>parameter 0-11 Programming Set-up</i> . Edit set-up for each communication channel. A means active set-up; F means factory; numbers indicate set-up code. Communication channels from right to left are LCP, FC-bus, USB, and HPFB1-5.

0-16 Application Selection		
Option:	Function:	
		Select integrated application functions. When an application is selected, a set of related parameters are set automatically.
[0] *	None	
[1]	Simple Process Close Loop	
[2]	Local/Remote	
[3]	Speed Open Loop	
[4]	Simple Speed Close Loop	
[5]	Multi Speed	

0-16 Application Selection		
Option:	Function:	
[6]	OGD LA10	
[7]	OGD V210	

4.1.3 0-2* LCP Display

Use parameters in this group to define the variables that are shown in the GLCP. *Parameter 16-17 Speed [RPM]* is one option for each parameter in *parameter group 0-2* LCP Display*.

0-20 Display Line 1.1 Small		
Select a variable to be shown in line 1, left position.		
Option:	Function:	
[0]	None	
[37]	Display Text 1	
[38]	Display Text 2	
[39]	Display Text 3	
[748]	PCD Feed Forward	
[953]	Profibus Warning Word	
[1501]	Running Hours	
[1502]	kWh Counter	
[1600]	Control Word	
[1601]	Reference [Unit]	
[1602] *	Reference [%]	
[1603]	Status Word	
[1605]	Main Actual Value [%]	
[1609]	Custom Readout	
[1610]	Power [kW]	
[1611]	Power [hp]	
[1612]	Motor Voltage	
[1613]	Frequency	
[1614]	Motor current	
[1615]	Frequency [%]	
[1616]	Torque [Nm]	
[1617]	Speed [RPM]	
[1618]	Motor Thermal	
[1622]	Torque [%]	
[1630]	DC Link Voltage	
[1633]	Brake Energy /2 min	
[1634]	Heatsink Temp.	
[1635]	Inverter Thermal	
[1636]	Inv. Nom. Current	
[1637]	Inv. Max. Current	
[1638]	SL Controller State	
[1639]	Control Card Temp.	
[1650]	External Reference	
[1652]	Feedback[Unit]	
[1653]	Digi Pot Reference	
[1657]	Feedback [RPM]	
[1660]	Digital Input	
[1661]	Terminal 53 Setting	
[1662]	Analog input 53	

0-20 Display Line 1.1 Small		
Select a variable to be shown in line 1, left position.		
Option:	Function:	
[1663]	Terminal 54 Setting	
[1664]	Analog input 54	
[1665]	Analog output 42 [mA]	
[1666]	Digital Output	
[1667]	Pulse input 29 [Hz]	
[1668]	Pulse input 33 [Hz]	
[1669]	Pulse output 27 [Hz]	
[1670]	Pulse output 29 [Hz]	
[1671]	Relay output	
[1672]	Counter A	
[1673]	Counter B	
[1679]	Analog output 45 [mA]	
[1680]	Fieldbus CTW 1	
[1682]	Fieldbus REF 1	
[1684]	Comm. Option STW	
[1685]	FC Port CTW 1	
[1686]	FC Port REF 1	
[1690]	Alarm Word	
[1691]	Alarm Word 2	
[1692]	Warning Word	
[1693]	Warning Word 2	
[1694]	Ext. Status Word	
[1695]	Ext. Status Word 2	
[1697]	Alarm Word 3	
[1890]	Process PID Error	
[1891]	Process PID Output	
[1892]	Process PID Clamped Output	
[1893]	Process PID Gain Scaled Output	
[2117]	Ext. 1 Reference [Unit]	
[2118]	Ext. 1 Feedback [Unit]	
[2119]	Ext. 1 Output [%]	
[3401]	PCD 1 Write For Application	
[3402]	PCD 2 Write For Application	
[3403]	PCD 3 Write For Application	
[3404]	PCD 4 Write For Application	
[3405]	PCD 5 Write For Application	
[3406]	PCD 6 Write For Application	
[3407]	PCD 7 Write For Application	
[3408]	PCD 8 Write For Application	
[3409]	PCD 9 Write For Application	
[3410]	PCD 10 Write For Application	
[3421]	PCD 1 Read For Application	
[3422]	PCD 2 Read For Application	
[3423]	PCD 3 Read For Application	
[3424]	PCD 4 Read For Application	
[3425]	PCD 5 Read For Application	
[3426]	PCD 6 Read For Application	
[3427]	PCD 7 Read For Application	
[3428]	PCD 8 Read For Application	
[3429]	PCD 9 Read For Application	
[3430]	PCD 10 Read For Application	

0-20 Display Line 1.1 Small		
Select a variable to be shown in line 1, left position.		
Option:	Function:	
[3450]	Actual Position	
[3456]	Track Error	

0-21 Display Line 1.2 Small		
Select a variable to be shown in line 1, middle position.		
Option:	Function:	
[0]	None	
[37]	Display Text 1	
[38]	Display Text 2	
[39]	Display Text 3	
[748]	PCD Feed Forward	
[953]	Profibus Warning Word	
[1501]	Running Hours	
[1502]	kWh Counter	
[1600]	Control Word	
[1601]	Reference [Unit]	
[1602]	Reference [%]	
[1603]	Status Word	
[1605]	Main Actual Value [%]	
[1609]	Custom Readout	
[1610]	Power [kW]	
[1611]	Power [hp]	
[1612]	Motor Voltage	
[1613]	Frequency	
[1614] *	Motor current	
[1615]	Frequency [%]	
[1616]	Torque [Nm]	
[1617]	Speed [RPM]	
[1618]	Motor Thermal	
[1622]	Torque [%]	
[1630]	DC Link Voltage	
[1633]	Brake Energy /2 min	
[1634]	Heatsink Temp.	
[1635]	Inverter Thermal	
[1636]	Inv. Nom. Current	
[1637]	Inv. Max. Current	
[1638]	SL Controller State	
[1639]	Control Card Temp.	
[1650]	External Reference	
[1652]	Feedback[Unit]	
[1653]	Digi Pot Reference	
[1657]	Feedback [RPM]	
[1660]	Digital Input	
[1661]	Terminal 53 Setting	
[1662]	Analog input 53	
[1663]	Terminal 54 Setting	
[1664]	Analog input 54	
[1665]	Analog output 42 [mA]	
[1666]	Digital Output	
[1667]	Pulse input 29 [Hz]	
[1668]	Pulse input 33 [Hz]	

0-21 Display Line 1.2 Small		
Select a variable to be shown in line 1, middle position.		
Option:	Function:	
[1669]	Pulse output 27 [Hz]	
[1670]	Pulse output 29 [Hz]	
[1671]	Relay output	
[1672]	Counter A	
[1673]	Counter B	
[1679]	Analog output 45 [mA]	
[1680]	Fieldbus CTW 1	
[1682]	Fieldbus REF 1	
[1684]	Comm. Option STW	
[1685]	FC Port CTW 1	
[1686]	FC Port REF 1	
[1690]	Alarm Word	
[1691]	Alarm Word 2	
[1692]	Warning Word	
[1693]	Warning Word 2	
[1694]	Ext. Status Word	
[1695]	Ext. Status Word 2	
[1697]	Alarm Word 3	
[1890]	Process PID Error	
[1891]	Process PID Output	
[1892]	Process PID Clamped Output	
[1893]	Process PID Gain Scaled Output	
[2117]	Ext. 1 Reference [Unit]	
[2118]	Ext. 1 Feedback [Unit]	
[2119]	Ext. 1 Output [%]	
[3401]	PCD 1 Write For Application	
[3402]	PCD 2 Write For Application	
[3403]	PCD 3 Write For Application	
[3404]	PCD 4 Write For Application	
[3405]	PCD 5 Write For Application	
[3406]	PCD 6 Write For Application	
[3407]	PCD 7 Write For Application	
[3408]	PCD 8 Write For Application	
[3409]	PCD 9 Write For Application	
[3410]	PCD 10 Write For Application	
[3421]	PCD 1 Read For Application	
[3422]	PCD 2 Read For Application	
[3423]	PCD 3 Read For Application	
[3424]	PCD 4 Read For Application	
[3425]	PCD 5 Read For Application	
[3426]	PCD 6 Read For Application	
[3427]	PCD 7 Read For Application	
[3428]	PCD 8 Read For Application	
[3429]	PCD 9 Read For Application	
[3430]	PCD 10 Read For Application	
[3450]	Actual Position	
[3456]	Track Error	

0-22 Display Line 1.3 Small		
Select a variable to be shown in line 1, right position.		
Option:	Function:	
[0]	None	
[37]	Display Text 1	
[38]	Display Text 2	
[39]	Display Text 3	
[748]	PCD Feed Forward	
[953]	Profibus Warning Word	
[1501]	Running Hours	
[1502]	kWh Counter	
[1600]	Control Word	
[1601]	Reference [Unit]	
[1602]	Reference [%]	
[1603]	Status Word	
[1605]	Main Actual Value [%]	
[1609]	Custom Readout	
[1610] *	Power [kW]	
[1611]	Power [hp]	
[1612]	Motor Voltage	
[1613]	Frequency	
[1614]	Motor current	
[1615]	Frequency [%]	
[1616]	Torque [Nm]	
[1617]	Speed [RPM]	
[1618]	Motor Thermal	
[1622]	Torque [%]	
[1630]	DC Link Voltage	
[1633]	Brake Energy /2 min	
[1634]	Heatsink Temp.	
[1635]	Inverter Thermal	
[1636]	Inv. Nom. Current	
[1637]	Inv. Max. Current	
[1638]	SL Controller State	
[1639]	Control Card Temp.	
[1650]	External Reference	
[1652]	Feedback[Unit]	
[1653]	Digi Pot Reference	
[1657]	Feedback [RPM]	
[1660]	Digital Input	
[1661]	Terminal 53 Setting	
[1662]	Analog input 53	
[1663]	Terminal 54 Setting	
[1664]	Analog input 54	
[1665]	Analog output 42 [mA]	
[1666]	Digital Output	
[1667]	Pulse input 29 [Hz]	
[1668]	Pulse input 33 [Hz]	
[1669]	Pulse output 27 [Hz]	
[1670]	Pulse output 29 [Hz]	
[1671]	Relay output	
[1672]	Counter A	
[1673]	Counter B	
[1679]	Analog output 45 [mA]	

0-22 Display Line 1.3 Small		
Select a variable to be shown in line 1, right position.		
Option:	Function:	
[1680]	Fieldbus CTW 1	
[1682]	Fieldbus REF 1	
[1684]	Comm. Option STW	
[1685]	FC Port CTW 1	
[1686]	FC Port REF 1	
[1690]	Alarm Word	
[1691]	Alarm Word 2	
[1692]	Warning Word	
[1693]	Warning Word 2	
[1694]	Ext. Status Word	
[1695]	Ext. Status Word 2	
[1697]	Alarm Word 3	
[1890]	Process PID Error	
[1891]	Process PID Output	
[1892]	Process PID Clamped Output	
[1893]	Process PID Gain Scaled Output	
[2117]	Ext. 1 Reference [Unit]	
[2118]	Ext. 1 Feedback [Unit]	
[2119]	Ext. 1 Output [%]	
[3401]	PCD 1 Write For Application	
[3402]	PCD 2 Write For Application	
[3403]	PCD 3 Write For Application	
[3404]	PCD 4 Write For Application	
[3405]	PCD 5 Write For Application	
[3406]	PCD 6 Write For Application	
[3407]	PCD 7 Write For Application	
[3408]	PCD 8 Write For Application	
[3409]	PCD 9 Write For Application	
[3410]	PCD 10 Write For Application	
[3421]	PCD 1 Read For Application	
[3422]	PCD 2 Read For Application	
[3423]	PCD 3 Read For Application	
[3424]	PCD 4 Read For Application	
[3425]	PCD 5 Read For Application	
[3426]	PCD 6 Read For Application	
[3427]	PCD 7 Read For Application	
[3428]	PCD 8 Read For Application	
[3429]	PCD 9 Read For Application	
[3430]	PCD 10 Read For Application	
[3450]	Actual Position	
[3456]	Track Error	

0-23 Display Line 2 Large		
Select a variable to be shown in line 2.		
Option:	Function:	
[0]	None	
[37]	Display Text 1	
[38]	Display Text 2	
[39]	Display Text 3	
[748]	PCD Feed Forward	
[953]	Profibus Warning Word	

0-23 Display Line 2 Large		
Select a variable to be shown in line 2.		
Option:	Function:	
[1501]	Running Hours	
[1502]	kWh Counter	
[1600]	Control Word	
[1601]	Reference [Unit]	
[1602]	Reference [%]	
[1603]	Status Word	
[1605]	Main Actual Value [%]	
[1609]	Custom Readout	
[1610]	Power [kW]	
[1611]	Power [hp]	
[1612]	Motor Voltage	
[1613] *	Frequency	
[1614]	Motor current	
[1615]	Frequency [%]	
[1616]	Torque [Nm]	
[1617]	Speed [RPM]	
[1618]	Motor Thermal	
[1622]	Torque [%]	
[1630]	DC Link Voltage	
[1633]	Brake Energy /2 min	
[1634]	Heatsink Temp.	
[1635]	Inverter Thermal	
[1636]	Inv. Nom. Current	
[1637]	Inv. Max. Current	
[1638]	SL Controller State	
[1639]	Control Card Temp.	
[1650]	External Reference	
[1652]	Feedback[Unit]	
[1653]	Digi Pot Reference	
[1657]	Feedback [RPM]	
[1660]	Digital Input	
[1661]	Terminal 53 Setting	
[1662]	Analog input 53	
[1663]	Terminal 54 Setting	
[1664]	Analog input 54	
[1665]	Analog output 42 [mA]	
[1666]	Digital Output	
[1667]	Pulse input 29 [Hz]	
[1668]	Pulse input 33 [Hz]	
[1669]	Pulse output 27 [Hz]	
[1670]	Pulse output 29 [Hz]	
[1671]	Relay output	
[1672]	Counter A	
[1673]	Counter B	
[1679]	Analog output 45 [mA]	
[1680]	Fieldbus CTW 1	
[1682]	Fieldbus REF 1	
[1684]	Comm. Option STW	
[1685]	FC Port CTW 1	
[1686]	FC Port REF 1	
[1690]	Alarm Word	

0-23 Display Line 2 Large		
Select a variable to be shown in line 2.		
Option:	Function:	
[1691]	Alarm Word 2	
[1692]	Warning Word	
[1693]	Warning Word 2	
[1694]	Ext. Status Word	
[1695]	Ext. Status Word 2	
[1697]	Alarm Word 3	
[1890]	Process PID Error	
[1891]	Process PID Output	
[1892]	Process PID Clamped Output	
[1893]	Process PID Gain Scaled Output	
[2117]	Ext. 1 Reference [Unit]	
[2118]	Ext. 1 Feedback [Unit]	
[2119]	Ext. 1 Output [%]	
[3401]	PCD 1 Write For Application	
[3402]	PCD 2 Write For Application	
[3403]	PCD 3 Write For Application	
[3404]	PCD 4 Write For Application	
[3405]	PCD 5 Write For Application	
[3406]	PCD 6 Write For Application	
[3407]	PCD 7 Write For Application	
[3408]	PCD 8 Write For Application	
[3409]	PCD 9 Write For Application	
[3410]	PCD 10 Write For Application	
[3421]	PCD 1 Read For Application	
[3422]	PCD 2 Read For Application	
[3423]	PCD 3 Read For Application	
[3424]	PCD 4 Read For Application	
[3425]	PCD 5 Read For Application	
[3426]	PCD 6 Read For Application	
[3427]	PCD 7 Read For Application	
[3428]	PCD 8 Read For Application	
[3429]	PCD 9 Read For Application	
[3430]	PCD 10 Read For Application	
[3450]	Actual Position	
[3456]	Track Error	

0-24 Display Line 3 Large		
Select a variable to be shown in line 3.		
Option:	Function:	
[0]	None	
[37]	Display Text 1	
[38]	Display Text 2	
[39]	Display Text 3	
[748]	PCD Feed Forward	
[953]	Profibus Warning Word	
[1501]	Running Hours	
[1502] *	kWh Counter	
[1600]	Control Word	
[1601]	Reference [Unit]	
[1602]	Reference [%]	
[1603]	Status Word	

0-24 Display Line 3 Large		
Select a variable to be shown in line 3.		
Option:	Function:	
[1605]	Main Actual Value [%]	
[1609]	Custom Readout	
[1610]	Power [kW]	
[1611]	Power [hp]	
[1612]	Motor Voltage	
[1613]	Frequency	
[1614]	Motor current	
[1615]	Frequency [%]	
[1616]	Torque [Nm]	
[1617]	Speed [RPM]	
[1618]	Motor Thermal	
[1622]	Torque [%]	
[1630]	DC Link Voltage	
[1633]	Brake Energy /2 min	
[1634]	Heatsink Temp.	
[1635]	Inverter Thermal	
[1636]	Inv. Nom. Current	
[1637]	Inv. Max. Current	
[1638]	SL Controller State	
[1639]	Control Card Temp.	
[1650]	External Reference	
[1652]	Feedback[Unit]	
[1653]	Digi Pot Reference	
[1657]	Feedback [RPM]	
[1660]	Digital Input	
[1661]	Terminal 53 Setting	
[1662]	Analog input 53	
[1663]	Terminal 54 Setting	
[1664]	Analog input 54	
[1665]	Analog output 42 [mA]	
[1666]	Digital Output	
[1667]	Pulse input 29 [Hz]	
[1668]	Pulse input 33 [Hz]	
[1669]	Pulse output 27 [Hz]	
[1670]	Pulse output 29 [Hz]	
[1671]	Relay output	
[1672]	Counter A	
[1673]	Counter B	
[1679]	Analog output 45 [mA]	
[1680]	Fieldbus CTW 1	
[1682]	Fieldbus REF 1	
[1684]	Comm. Option STW	
[1685]	FC Port CTW 1	
[1686]	FC Port REF 1	
[1690]	Alarm Word	
[1691]	Alarm Word 2	
[1692]	Warning Word	
[1693]	Warning Word 2	
[1694]	Ext. Status Word	
[1695]	Ext. Status Word 2	
[1697]	Alarm Word 3	

0-24 Display Line 3 Large		
Select a variable to be shown in line 3.		
Option:	Function:	
[1890]	Process PID Error	
[1891]	Process PID Output	
[1892]	Process PID Clamped Output	
[1893]	Process PID Gain Scaled Output	
[2117]	Ext. 1 Reference [Unit]	
[2118]	Ext. 1 Feedback [Unit]	
[2119]	Ext. 1 Output [%]	
[3401]	PCD 1 Write For Application	
[3402]	PCD 2 Write For Application	
[3403]	PCD 3 Write For Application	
[3404]	PCD 4 Write For Application	
[3405]	PCD 5 Write For Application	
[3406]	PCD 6 Write For Application	
[3407]	PCD 7 Write For Application	
[3408]	PCD 8 Write For Application	
[3409]	PCD 9 Write For Application	
[3410]	PCD 10 Write For Application	
[3421]	PCD 1 Read For Application	
[3422]	PCD 2 Read For Application	
[3423]	PCD 3 Read For Application	
[3424]	PCD 4 Read For Application	
[3425]	PCD 5 Read For Application	
[3426]	PCD 6 Read For Application	
[3427]	PCD 7 Read For Application	
[3428]	PCD 8 Read For Application	
[3429]	PCD 9 Read For Application	
[3430]	PCD 10 Read For Application	
[3450]	Actual Position	
[3456]	Track Error	

4.1.4 0-3* LCP Custom Readout

It is possible to customise the display elements in the LCP.

Custom readout

The calculated value to be shown is based on settings in *parameter 0-30 Custom Readout Unit*, *parameter 0-31 Custom Readout Min Value* (linear only), *parameter 0-32 Custom Readout Max Value*, *parameter 4-14 Motor Speed High Limit [Hz]*, and actual speed.

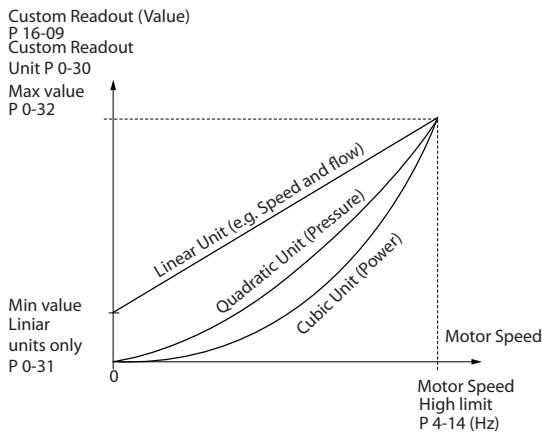

Illustration 4.1 Custom Readout

The relation depends on the type of unit selected in *parameter 0-30 Custom Readout Unit*:

Unit type	Speed relation
Dimensionless	Linear
Speed	
Flow, volume	
Flow, mass	
Velocity	
Length	
Temperature	
Pressure	
Power	Cubic

Table 4.1 Relation between Unit Type and Speed

0-30 Custom Readout Unit	
Option:	Function:
	Set a value to be shown in the LCP. The value has a linear, squared, or cubed relation to speed. This relation depends on the unit selected. See Table 4.1. The actual calculated value can be read in <i>parameter 16-09 Custom Readout</i> .
[0]	None
[1] *	%
[5]	PPM
[10]	l/min
[11]	RPM
[12]	Pulse/s
[20]	l/s
[21]	l/min
[22]	l/h
[23]	m ³ /s
[24]	m ³ /min
[25]	m ³ /h
[30]	kg/s
[31]	kg/min
[32]	kg/h
[33]	t/min
[34]	t/h
[40]	m/s
[41]	m/min
[45]	m
[60]	°C
[70]	mbar
[71]	bar
[72]	Pa
[73]	kPa
[74]	m WG
[80]	kW
[120]	GPM
[121]	gal/s
[122]	gal/min
[123]	gal/h
[124]	CFM
[127]	ft ³ /h
[140]	ft/s
[141]	ft/min
[160]	°F
[170]	psi
[171]	lb/in ²
[172]	in WG
[173]	ft WG
[180]	HP

0-31 Custom Readout Min Value		
Range:	Function:	
0 CustomReadoutUnit*	[0 - 999999.99 CustomReadoutUnit]	This parameter sets the minimum value of the custom readout (occurs at 0 speed). It is only possible to select a value different from 0 when selecting a linear unit in <i>parameter 0-30 Custom Readout Unit</i> . For quadratic and cubic units, the minimum value is 0.

0-32 Custom Readout Max Value		
Range:	Function:	
100 CustomReadoutUnit*	[0.0 - 999999.99 CustomReadoutUnit]	This parameter sets the maximum value to be shown when the motor speed has reached the value set in <i>parameter 4-14 Motor Speed High Limit [Hz]</i> .

0-37 Display Text 1		
Range:	Function:	
[0 - 0]	Free text, for example used for the device tag of fieldbus application.	

0-38 Display Text 2		
Range:	Function:	
[0 - 0]	Free text, for example used for the location tag of fieldbus application.	

0-39 Display Text 3		
Range:	Function:	
[0 - 0]	Free text, for example used for the help tag of fieldbus application.	

4.1.5 0-4* LCP Keypad

Enable, disable, and password protect individual keys on the LCP.

0-40 [Hand on] Key on LCP		
Option:	Function:	
[0]	Disabled	Avoid accidental start of the frequency converter in hand-on mode.
[1] *	Enabled	[Hand On] is enabled.

0-42 [Auto on] Key on LCP		
Option:	Function:	
[0]	Disabled	Avoid accidental start of the frequency converter from LCP.
[1] *	Enabled	[Hand On] is enabled.

0-44 [Off/Reset] Key on LCP		
Option:	Function:	
[0]	Disabled	
[1] *	Enabled	
[7]	Enable Reset Only	

4.1.6 0-5* Copy/Save

Copy parameters from and to NLCP and GLCP. Use these parameters for saving and copying set-ups from 1 frequency converter to another.

0-50 LCP Copy		
Option:	Function:	
[0] *	No copy	No function.
[1]	All to LCP	Copy all parameters in all set-ups from the frequency converter memory to the LCP. For service purposes, copy all parameters to the LCP after commissioning.
[2]	All from LCP	Copy all parameters in all set-ups from the LCP memory to the frequency converter memory.
[3]	Size indep. from LCP	Copy only the parameters that are independent of the motor size. This selection can be used to program several frequency converters with the same function without disturbing motor data that is already set.

0-51 Set-up Copy		
Option:	Function:	
[0] *	No copy	No function.
[1]	Copy from setup 1	Copy from set-up 1 to set-up 2.
[2]	Copy from setup 2	Copy from set-up 2 to set-up 1.
[9]	Copy from Factory setup	Copy factory setting to programming set-up (selected in <i>parameter 0-11 Programming Set-up</i>).

4.1.7 0-6* Password

0-60 Main Menu Password		
Range:	Function:	
0*	[0 - 999]	Define the password for access to the <i>Main Menu</i> via the [Main Menu] key. Setting values to 0 disables the password function.

4.2 Parameters: 1-** Load and Motor

4.2.1 1-0* General Settings

1-00 Configuration Mode		
Option:	Function:	
		Select the application control principle to be used when a remote reference (that is, via analog input or fieldbus) is active.
[0]	Open Loop *	Enables speed control (without feedback signal from motor) with automatic slip compensation for almost constant speed at varying loads. Compensations are active, but can be disabled in <i>parameter group 1-** Load and Motor</i> .
[1]	Speed closed loop	Enables speed closed-loop control with feedback. For increased speed accuracy, provide a feedback signal and set the speed PID control. The speed control parameters are set in <i>parameter group 7-0* Speed PID Control</i> .
[2]	Torque closed loop	Enables torque closed-loop control with speed feedback. Only possible when option [1] VVC+ is selected in <i>parameter 1-01 Motor Control Principle</i> .
[3]	Process Closed Loop	Enables the use of process control in the frequency converter. The process control parameters are set in <i>parameter group 7-2* Process Ctrl. Feedb.</i> and <i>parameter group 7-3* Process PID Ctrl.</i>
[4]	Torque open loop	Enables the use of torque open loop in VVC+ mode (<i>parameter 1-01 Motor Control Principle</i>). The torque PID parameters are set in <i>parameter group 7-1* Torque PI Control</i> .
[6]	Surface Winder	Enables the use of surface winder control. Specific parameters in <i>parameter group 7-2* Process Ctrl. Feedb.</i> and <i>parameter group 7-3* Process PID Ctrl.</i>
[7]	Extended PID Speed OL	Enables the use of extended PID speed OL. Specific parameters in <i>parameter group 7-2* Process Ctrl. Feedb.</i> to <i>parameter group 7-5* Ext. Process PID Ctrl.</i>

1-01 Motor Control Principle		
Option:	Function:	
[0]	U/f	<p>NOTICE</p> <p>When running U/f, control slip and load compensations are not included.</p> <p>Used for parallel-connected motors and/or special motor applications. Set the U/f settings in</p>

1-01 Motor Control Principle		
Option:	Function:	
		<p><i>parameter 1-55 U/f Characteristic - U</i> and <i>parameter 1-56 U/f Characteristic - F</i>.</p>
[1] *	VVC+	<p>NOTICE</p> <p>When <i>parameter 1-10 Motor Construction</i> is set to PM-enabled options, only VVC+ option is available.</p> <p>Normal running mode, including slip and load compensations.</p>

1-03 Torque Characteristics		
Option:	Function:	
		Select the torque characteristic required. VT and AEO are both energy-saving operations.
[0] *	Constant torque	Motor shaft output provides constant torque under variable speed control.
[1]	Variable Torque	Motor shaft output provides variable torque under variable speed control. Set the variable torque level in <i>parameter 14-40 VT Level</i> .
[2]	Auto Energy Optim. CT	Automatically optimizes energy consumption by minimizing magnetization and frequency via <i>parameter 14-41 AEO Minimum Magnetization</i> .

1-06 Clockwise Direction		
Option:	Function:	
		<p>NOTICE</p> <p>This parameter cannot be adjusted while the motor is running.</p> <p>This parameter defines the term <i>clockwise</i> corresponding to the LCP direction arrow. Used for easy change of direction of shaft rotation without swapping motor wires.</p>
[0] *	Normal	The motor shaft turns in clockwise direction when frequency converter is connected U⇒U; V⇒V; and W⇒W to motor.
[1]	Inverse	The motor shaft turns in counterclockwise direction when frequency converter is connected U⇒U; V⇒V; and W⇒W to motor.

1-08 Motor Control Bandwidth		
Option:	Function:	
[0]	High	Suitable for high dynamic response.
[1] *	Medium	Suitable for smooth steady-state operation.
[2]	Low	Suitable for smooth steady-state operation with lowest dynamic response.
[3]	Adaptive 1	Optimized for smooth steady-state operation, with extra active damping.

1-08 Motor Control Bandwidth

Option: **Function:**

[4]	Adaptive 2	Focus on low-inductance PM motors. This option is an alternative to [3] Adaptive 1.
-----	------------	---

4.2.2 1-1* Motor Selection

Parameter group for setting general motor data. The parameters cannot be adjusted while the motor is running.

The active parameters are shown in *Table 4.2*. x indicates that a particular parameter is active when the option is selected.

4

<i>Parameter 1-10 Motor Construction</i>	<i>[0] Asynchron</i>	<i>[1] PM, non salient SPM</i>	<i>[3] PM, salient IPM</i>
<i>Parameter 1-00 Configuration Mode</i>	x	x	x
<i>Parameter 1-03 Torque Characteristics</i>	x		
<i>Parameter 1-06 Clockwise Direction</i>	x	x	x
<i>Parameter 1-08 Motor Control Bandwidth</i>	x	x	x
<i>Parameter 1-14 Damping Gain</i>		x	x
<i>Parameter 1-15 Low Speed Filter Time Const.</i>		x	x
<i>Parameter 1-16 High Speed Filter Time Const.</i>		x	x
<i>Parameter 1-17 Voltage filter time const.</i>		x	x
<i>Parameter 1-20 Motor Power [kW]</i>	x		
<i>Parameter 1-22 Motor Voltage</i>	x		
<i>Parameter 1-23 Motor Frequency</i>	x		
<i>Parameter 1-24 Motor Current</i>	x	x	x
<i>Parameter 1-25 Motor Nominal Speed</i>	x	x	x
<i>Parameter 1-26 Motor Cont. Rated Torque</i>		x	x
<i>Parameter 1-29 Automatic Motor Adaption (AMA)</i>	x	x	x
<i>Parameter 1-30 Stator Resistance (Rs)</i>	x	x	x
<i>Parameter 1-31 Rotor Resistance (Rr)</i>	x		
<i>Parameter 1-33 Stator Leakage Reactance (X1)</i>	x		
<i>Parameter 1-35 Main Reactance (Xh)</i>	x		
<i>Parameter 1-37 d-axis Inductance (Ld)</i>		x	x
<i>Parameter 1-38 q-axis Inductance (Lq)</i>			x
<i>Parameter 1-39 Motor Poles</i>	x	x	x
<i>Parameter 1-40 Back EMF at 1000 RPM</i>		x	x
<i>Parameter 1-42 Motor Cable Length</i>	x	x	x
<i>Parameter 1-43 Motor Cable Length Feet</i>	x	x	x
<i>Parameter 1-44 d-axis Inductance Sat. (LdSat)</i>			x
<i>Parameter 1-45 q-axis Inductance Sat. (LqSat)</i>			x
<i>Parameter 1-46 Position Detection Gain</i>		x	x
<i>Parameter 1-48 Current at Min Inductance for d-axis</i>			x
<i>Parameter 1-49 Current at Min Inductance for q-axis</i>			x
<i>Parameter 1-50 Motor Magnetisation at Zero Speed</i>	x		
<i>Parameter 1-52 Min Speed Normal Magnetising [Hz]</i>	x		
<i>Parameter 1-55 U/f Characteristic - U</i>	x		
<i>Parameter 1-56 U/f Characteristic - F</i>	x		
<i>Parameter 1-60 Low Speed Load Compensation</i>	x		
<i>Parameter 1-61 High Speed Load Compensation</i>	x		
<i>Parameter 1-62 Slip Compensation</i>	x		
<i>Parameter 1-63 Slip Compensation Time Constant</i>	x		
<i>Parameter 1-64 Resonance Dampening</i>	x		
<i>Parameter 1-65 Resonance Dampening Time Constant</i>	x		
<i>Parameter 1-66 Min. Current at Low Speed</i>		x	x
<i>Parameter 1-70 PM Start Mode</i>		x	x

Parameter 1-10 Motor Construction	[0] Asynchron	[1] PM, non salient SPM	[3] PM, salient IPM
Parameter 1-71 Start Delay	x	x	x
Parameter 1-72 Start Function	x	x	x
Parameter 1-73 Flying Start	x	x	x
Parameter 1-80 Function at Stop	x	x	x
Parameter 1-88 AC Brake Gain	x		
Parameter 1-90 Motor Thermal Protection	x	x	x
Parameter 2-00 DC Hold Current	x	x	x
Parameter 2-01 DC Brake Current	x	x	x
Parameter 2-02 DC Braking Time	x	x	x
Parameter 2-04 DC Brake Cut In Speed [Hz]	x	x	x
Parameter 2-06 Parking Current		x	x
Parameter 2-07 Parking Time		x	x
Parameter 2-10 Brake Function	x	x	x
Parameter 2-16 AC brake Max. Current	x		
Parameter 2-17 Over-voltage Control	x	x	x
Parameter 4-10 Motor Speed Direction	x	x	x
Parameter 4-14 Motor Speed High Limit [Hz]	x	x	x
Parameter 4-16 Torque Limit Motor Mode	x		
Parameter 4-17 Torque Limit Generator Mode	x		
Parameter 4-18 Current Limit	x	x	x
Parameter 4-19 Max Output Frequency	x	x	x
Parameter 4-58 Missing Motor Phase Function	x	x	x
Parameter 14-01 Switching Frequency	x	x	x
Parameter 14-03 Overmodulation	x	x	x
Parameter 14-07 Dead Time Compensation Level	x	x	x
Parameter 14-08 Damping Gain Factor	x	x	x
Parameter 14-09 Dead Time Bias Current Level	x	x	x
Parameter 14-10 Mains Failure	x		
Parameter 14-11 Mains Voltage at Mains Fault	x		
Parameter 14-12 Function at Mains Imbalance	x	x	x
Parameter 14-27 Action At Inverter Fault	x	x	x
Parameter 14-40 VT Level	x		
Parameter 14-41 AEO Minimum Magnetisation	x		
Parameter 14-50 RFI Filter	x	x	x
Parameter 14-51 DC-Link Voltage Compensation	x	x	x
Parameter 14-55 Output Filter	x	x	x
Parameter 14-64 Dead Time Compensation Zero Current Level	x	x	x
Parameter 14-65 Speed Derate Dead Time Compensation	x	x	x
Parameter 30-22 Locked Rotor Detection		x	x
Parameter 30-23 Locked Rotor Detection Time [s]		x	x

Table 4.2 Active Parameters

1-10 Motor Construction		
Option:	Function:	
[0] *	Asynchron	For asynchronous motors.
[1]	PM, non salient SPM	For permanent magnet (PM) motors with surface-mounted (non-salient) magnets. Refer to <i>parameter 1-14 Damping Gain</i> to <i>parameter 1-17 Voltage filter time const.</i> for details about optimizing the motor operation.
[3]	PM, salient IPM	For permanent magnet (PM) motors with interior (salient) magnets.

1-14 Damping Gain		
Range:	Function:	
120 %*	[0 - 250 %]	The damping gain stabilizes the PM machine. The value of damping gain controls the dynamic performance of the PM machine. High damping gain gives high dynamic performance, and low damping gain gives low dynamic performance. The dynamic performance is related to the machine data and load type. If the damping gain is too high or low, the control becomes unstable.

1-15 Low Speed Filter Time Const.		
Range:	Function:	
Size related*	[0.01 - 20 s]	This time constant is used below 10% rated speed. Obtain quick control through a short damping time constant. However, if this value is too short, the control becomes unstable.

1-16 High Speed Filter Time Const.		
Range:	Function:	
Size related*	[0.01 - 20 s]	This time constant is used above 10% rated speed. Obtain quick control through a short damping time constant. However, if this value is too short, the control becomes unstable.

1-17 Voltage filter time const.		
Range:	Function:	
Size related*	[0.001 - 1 s]	Reduces the influence of high frequency ripple and system resonance in the calculation of supply voltage. Without this filter, the ripples in the currents can distort the calculated voltage and affect the stability of the system.

4.2.3 1-2* Motor Data

This parameter group comprises input data from the nameplate on the connected motor.

NOTICE

Changing the value of these parameters affects the setting of other parameters.

1-20 Motor Power		
Option:	Function:	
[2]	0.12 kW - 0.16 hp	
[3]	0.18 kW - 0.25 hp	
[4]	0.25 kW - 0.33 hp	
[5]	0.37 kW - 0.5 hp	
[6]	0.55 kW - 0.75 hp	
[7]	0.75 kW - 1 hp	
[8]	1.1 kW - 1.5 hp	
[9]	1.5 kW - 2 hp	
[10]	2.2 kW - 3 hp	
[11]	3 kW - 4 hp	
[12]	3.7 kW - 5 hp	
[13]	4 kW - 5.4 hp	
[14]	5.5 kW - 7.5 hp	
[15]	7.5 kW - 10 hp	
[16]	11 kW - 15 hp	
[17]	15 kW - 20 hp	
[18]	18.5 kW - 25 hp	
[19]	22 kW - 30 hp	
[20]	30 kW - 40 hp	
[21]	37 kW - 50 hp	
[22]	45 kW - 60 hp	
[23]	55 kW - 75 hp	
[24]	75 kW - 100 hp	
[25]	90 kW - 120 hp	

1-22 Motor Voltage		
Range:	Function:	
Size related*	[50 - 1000 V]	Enter the nominal motor voltage according to the motor nameplate data. The default value corresponds to the nominal rated output of the unit.

1-23 Motor Frequency		
Range:		Function:
		NOTICE This parameter cannot be adjusted while the motor is running.
Size related*	[20 - 500 Hz]	Select the motor frequency value from the motor nameplate. For 87 Hz operation with 230/440 V motors, set the value according to the nameplate data for 230 V/50 Hz. Adapt <i>parameter 4-14 Motor Speed High Limit [Hz]</i> and <i>parameter 3-03 Maximum Reference</i> to the 87 Hz application.

1-24 Motor Current		
Range:		Function:
Size related*	[0.01 - 1000.00 A]	Enter the nominal motor current value from the motor nameplate data. This data is used for calculating motor torque, motor thermal protection, and so on.

1-25 Motor Nominal Speed		
Range:		Function:
Size related*	[50 - 60000 RPM]	Enter the nominal motor speed value from the motor nameplate data. This data is used for calculating automatic motor compensations.

1-26 Motor Cont. Rated Torque		
Range:		Function:
Size related*	[0.1 - 10000.0 Nm]	Enter the value from the motor nameplate data. The default value corresponds to the nominal rated output. This parameter is available when <i>parameter 1-10 Motor Construction</i> is set to [1] PM, non salient SPM or [3] PM, salient IPM, that is, the parameter is valid for PM, non-salient SPM and PM, salient IPM motors only.

1-29 Automatic Motor Adaption (AMA)		
Option:		Function:
		NOTICE This parameter cannot be adjusted while the motor is running.

1-29 Automatic Motor Adaption (AMA)		
Option:		Function:
		NOTICE Terminal 27 digital input (<i>parameter 5-12 Terminal 27 Digital Input</i>) has coast inverse as the default setting. This setting means that AMA cannot be performed if terminal 27 is switched off. The AMA function optimizes dynamic motor performance by automatically optimizing the advanced motor parameters.
[0]	Off	No function.
[1]	Enable Complete AMA	Depending on the option selected in <i>parameter 1-10 Motor Construction</i> , the AMA is performed on different parameters. <ul style="list-style-type: none"> If [0] Asynchron is selected, the AMA is performed on: <ul style="list-style-type: none"> - <i>Parameter 1-30 Stator Resistance (Rs)</i>. - <i>Parameter 1-31 Rotor Resistance (Rr)</i>. - <i>Parameter 1-33 Stator Leakage Reactance (X1)</i>. - <i>Parameter 1-35 Main Reactance (Xh)</i>. If [1] PM, non-salient SPM is selected, the AMA is performed on: <ul style="list-style-type: none"> - <i>Parameter 1-30 Stator Resistance (Rs)</i>. - <i>Parameter 1-37 d-axis Inductance (Ld)</i>. If [3] PM, salient IPM is selected, the AMA is performed on: <ul style="list-style-type: none"> - <i>Parameter 1-30 Stator Resistance (Rs)</i>. - <i>Parameter 1-37 d-axis Inductance (Ld)</i>. - <i>Parameter 1-38 q-axis Inductance (Lq)</i>. - <i>Parameter 1-44 d-axis Inductance Sat. (LdSat)</i>. - <i>Parameter 1-45 q-axis Inductance Sat. (LqSat)</i>.
[2]	Enable Reduced AMA	Perform a reduced AMA of the stator resistance R_s (<i>parameter 1-30 Stator Resistance (Rs)</i>) in the system only. If an LC filter is used between the frequency converter and the motor, select this option. (This option is only for asynchronous motors.)

When parameter 1-10 Motor Construction is set to options that enable permanent motor mode, the only option available is [1] Enable Complete AMA.

Activate the AMA function by pressing [Hand On] after selecting [1] Enable Complete AMA or [2] Enable Reduced AMA. After a normal sequence, the display reads: Press [OK] to finish AMA. After pressing [OK], the frequency converter is ready for operation.

NOTICE

- For the best adaptation of the frequency converter, run AMA on a cold motor.
- AMA cannot be performed while the motor is running.

NOTICE

Avoid generating external torque during AMA.

If an LC filter is used, set the frequency converter to run in U/f control mode (recommended), or perform reduced AMA in VVC+ mode. If an LC filter is not used, perform complete AMA.

4.2.4 1-3* Adv. Motor Data I

Set parameters for advanced motor data. The motor data in parameters 1-30 to 1-39 must match the motor for optimal performance. If the motor data is not known, running an AMA is recommended.

1-30 Stator Resistance (Rs)		
Range:	Function:	
Size related* [0.0 - 9999.000 Ohm]	<p>NOTICE</p> <p>This parameter cannot be adjusted while the motor is running.</p> <p>Set the stator resistance value. Enter the value from a motor datasheet or perform an AMA on a cold motor.</p>	

1-31 Rotor Resistance (Rr)		
Range:	Function:	
Size related* [0 - 9999.000 Ohm]	<p>NOTICE</p> <p>This parameter cannot be adjusted while the motor is running.</p> <p>Enter the rotor resistance value. Obtain the value from a motor datasheet or by performing an AMA on a cold</p>	

1-31 Rotor Resistance (Rr)		
Range:	Function:	
	<p>motor. The default setting is calculated by the frequency converter from the motor nameplate data.</p>	

1-33 Stator Leakage Reactance (X1)		
Range:	Function:	
Size related* [0.0 - 9999.000 Ohm]	<p>NOTICE</p> <p>This parameter cannot be adjusted while the motor is running.</p> <p>Set the stator leakage reactance value. Obtain the value from a motor datasheet or perform an AMA on a cold motor. The default setting is calculated by the frequency converter from the motor nameplate data.</p>	

1-35 Main Reactance (Xh)		
Range:	Function:	
Size related* [0.0 - 9999.00 Ohm]	<p>NOTICE</p> <p>This parameter cannot be adjusted while the motor is running.</p> <p>Set the main reactance of the motor using 1 of these methods:</p> <ul style="list-style-type: none"> • Run an AMA on a cold motor. The frequency converter measures the value from the motor. • Enter the X_h value manually. Obtain the value from the motor supplier. • Use the X_h default setting. The frequency converter establishes the setting based on the motor nameplate data. 	

1-37 d-axis Inductance (Ld)		
Range:	Function:	
Size related* [0 - 65535 mH]	<p>NOTICE</p> <p>This parameter cannot be adjusted while the motor is running.</p> <p>Enter the value of the d-axis inductance. Obtain the value from the permanent magnet motor datasheet or perform an AMA on a cold motor.</p>	

1-38 q-axis Inductance (Lq)		
Range:		Function:
Size related*	[0.000 - 65535 mH]	<p>NOTICE</p> <p>This parameter cannot be adjusted while the motor is running.</p> <p>Set the value of the q-axis inductance. Find the value in the motor datasheet or perform an AMA on a cold motor.</p>

1-39 Motor Poles		
Range:		Function:
Size related*	[2 - 100]	<p>NOTICE</p> <p>This parameter cannot be adjusted while the motor is running.</p> <p>Enter the number of motor poles.</p> <p>The motor pole value is always an even number, because it refers to the total pole numbers, not pairs of poles.</p>

1-42 Motor Cable Length		
Range:		Function:
50 m*	[0 - 100 m]	Set the motor cable length in meters.

1-43 Motor Cable Length Feet		
Range:		Function:
164 ft*	[0 - 328 ft]	Set the motor cable length. The length unit is foot.

1-44 d-axis Inductance Sat. (LdSat)		
Range:		Function:
Size related	[0 - 65535 mH]	<p>This parameter is active only when <i>parameter 1-10 Motor Construction</i> is set to [3] PM, salient IPM.</p> <p>This parameter corresponds to the saturation inductance of d-axis. The default value is the value set in <i>parameter 1-37 d-axis Inductance (Ld)</i>. In most cases, do not change the default value. If the motor supplier provides the saturation curve, enter the d-axis inductance value, which is under 100% of the nominal current or perform an AMA on a cold motor.</p>

4.2.5 1-4* Adv. Motor Data II

Set parameters for advanced motor data.

1-40 Back EMF at 1000 RPM		
Range:		Function:
Size related*	[1 - 9000 V]	<p>Set the nominal back EMF for the motor when running at 1000 RPM.</p> <p>Back EMF is the voltage generated by a PM motor when no frequency converter is connected and the shaft is turned externally. Back EMF is normally specified for nominal motor speed or for 1000 RPM measured between 2 lines. If the value is not available for a motor speed of 1000 RPM, calculate the correct value as follows: If back EMF is, for example, 320 V at 1800 RPM, it can be calculated at 1000 RPM:</p> <p>Example</p> <p>Back EMF 320 V at 1800 RPM. Back EMF = (Voltage/RPM)*1000 = (320/1800)*1000 = 178.</p> <p>This parameter is only active when <i>parameter 1-10 Motor Construction</i> is set to options that enable PM (permanent magnet) motors.</p> <p>NOTICE</p> <p>When using PM motors, it is recommended to use brake resistors.</p>

1-45 q-axis Inductance Sat. (LqSat)		
Range:		Function:
Size related*	[0 - 65535 mH]	<p>This parameter is active only when <i>parameter 1-10 Motor Construction</i> is set to [3] PM, salient IPM.</p> <p>This parameter corresponds to the q-axis saturation inductance. The default value is the value set in <i>parameter 1-38 q-axis Inductance (Lq)</i>. In most cases, do not change the default value. If the motor supplier provides the saturation curve, enter the q-axis inductance value, which is under 100% of the nominal current or perform an AMA on a cold motor.</p>

1-46 Position Detection Gain		
Range:		Function:
100 %*	[20 - 200 %]	Adjust the amplitude of the test pulse during position detection at start. Adjust this parameter to improve the position measurement.

1-48 Current at Min Inductance for d-axis		
Range:		Function:
100 %	[20 - 200 %]	Use this parameter to set the inductance saturation point.

1-49 Current at Min Inductance for q-axis		
Range:	Function:	
100 % [20 - 200 %]	This parameter specifies the saturation curve of the q-inductance values. From 20–100% of this parameter, the inductance is linearly approximated due to <i>parameter 1-38 q-axis Inductance (Lq)</i> and <i>parameter 1-45 q-axis Inductance Sat. (LqSat)</i> . These parameters are related to the motor nameplate load compensations, the application load type, and the electronic brake function for quick stop/hold of the motor.	

4.2.6 1-5* Load Indep. Setting

Parameters for load-independent motor settings.

1-50 Motor Magnetisation at Zero Speed		
Range:	Function:	
100 %* [0 - 300 %]	Use this parameter along with <i>parameter 1-52 Min Speed Normal Magnetising [Hz]</i> to obtain a different thermal load on the motor when running at low speed. Enter a value that is a percentage of the rated magnetizing current. If the setting is too low, the torque on the motor shaft may be reduced.	

Illustration 4.2 Motor Magnetization

1-52 Min Speed Normal Magnetising [Hz]		
Range:	Function:	
1 Hz* [0.1 - 10.0 Hz]	Set the required frequency for normal magnetizing current. Use this parameter along with <i>parameter 1-50 Motor Magnetisation at Zero Speed</i> , also see <i>Illustration 4.2</i> .	

1-55 U/f Characteristic - U		
Range:	Function:	
Size related* [0 - 1000 V]	Enter voltage at each frequency point to manually form a U/f characteristic matching motor. Frequency points are defined in <i>parameter 1-56 U/f Characteristic - F</i> .	

1-56 U/f Characteristic - F		
Range:	Function:	
Size related* [0 - 500.0 Hz]	Enter frequency points to form a U/f characteristic matching motor. Voltage at each point is defined in <i>parameter 1-55 U/f Characteristic - U</i> . Make a U/f characteristic based on 6 definable voltages and frequencies, see <i>Illustration 4.3</i> .	

Illustration 4.3 Example of U/f Characteristic

4.2.7 1-6* Load Depen. Setting

Parameters for adjusting the load-dependent motor settings.

1-60 Low Speed Load Compensation		
Range:	Function:	
100 %* [0 - 300 %]	Enter the low-speed voltage compensation value in percent. This parameter is used for optimizing the low-speed load performance. This parameter is only active if <i>parameter 1-10 Motor Construction = [0] Asynchron</i> .	

1-61 High Speed Load Compensation		
Range:	Function:	
100 %* [0 - 300 %]	Enter the high-speed load voltage compensation value in percent. This parameter is used for optimizing the high-speed load performance. This parameter is only active if <i>parameter 1-10 Motor Construction = [0] Asynchron</i> .	

1-62 Slip Compensation		
Range:	Function:	
Size related* [-400 - 400.0 %]	Enter the % value for slip compensation to compensate for tolerance in the value of $n_{M,N}$. Slip compensation is calculated automatically, that is, based on the nominal motor speed $n_{M,N}$.	

1-63 Slip Compensation Time Constant		
Range:		Function:
0.1 s*	[0.05 - 5 s]	Enter the slip compensation reaction speed. A high value results in slow reaction, and a low value results in quick reaction. If low-frequency resonance problems occur, use a longer time setting.

1-64 Resonance Dampening		
Range:		Function:
100 %*	[0 - 500 %]	Enter the resonance dampening value. Set <i>parameter 1-64 Resonance Dampening</i> and <i>parameter 1-65 Resonance Dampening Time Constant</i> to help eliminate high-frequency resonance problems. To reduce resonance oscillation, increase the value of <i>parameter 1-64 Resonance Dampening</i> .

1-65 Resonance Dampening Time Constant		
Range:		Function:
0.005 s*	[0.001 - 0.05 s]	Set <i>parameter 1-64 Resonance Dampening</i> and <i>parameter 1-65 Resonance Dampening Time Constant</i> to help eliminate high-frequency resonance problems. Enter the time constant that provides the best dampening.

1-66 Min. Current at Low Speed		
Range:		Function:
50 %*	[0 - 120 %]	Enter the minimum motor current at low speed. Increasing this current improves motor torque at low speed. <i>Parameter 1-66 Min. Current at Low Speed</i> is enabled only for PM motor.

4.2.8 1-7* Start Adjustments

Parameters for adjusting the motor start settings.

1-70 Start Mode		
Select the PM motor start-up mode. To initialize the VVC ⁺ control core for previously free-running PM motor. Active for PM motors in VVC ⁺ only if the motor is stopped (or running at very low speed).		
Option:		Function:
[0] *	Rotor Detection	Estimates the electrical angle of the rotor and uses this angle as a starting point. This option is the standard selection for industrial applications. If flystart detects that the motor runs at low speed or has stopped, the frequency converter detects the rotor position (the angle) and starts the motor from that position.
[1]	Parking	The parking function applies DC current across the stator winding and rotates the rotor to electrical 0 position. This option is typically for pump and fan applications. If flystart detects that the motor runs at low speed or has stopped, the frequency converter sends out a DC current to make the motor park at an angle and then starts the motor from that position.

1-71 Start Delay		
Range:		Function:
0 s*	[0.0 - 10.0 s]	This parameter enables a delay of the starting time. The frequency converter begins with the start function selected in <i>parameter 1-72 Start Function</i> . Set the start delay time until acceleration is to begin.

1-72 Start Function		
Option:		Function:
		Select the start function during start delay. This parameter is linked to <i>parameter 1-71 Start Delay</i> .
[0]	DC Hold/delay time	Energizes motor with a DC hold current (<i>parameter 2-00 DC Hold/Motor Preheat Current</i>) during the start delay time.
[2] *	Coast/delay time	Motor coasted during the start delay time (inverter off).
[3]	Start speed cw	Only possible with VVC ⁺ . Regardless of the value applied by the reference signal, the output speed applies the setting of the start speed in <i>parameter 1-75 Start Speed [Hz]</i> and the output current corresponds to the setting of the start current in <i>parameter 1-76 Start Current</i> . This function is typically used in hoisting applications without counterweight

1-72 Start Function		
Option:	Function:	
		and especially in applications with a Cone-motor, where the start is clockwise, followed by rotation in the reference direction.
[4]	Horizontal operation	Only possible with VVC ⁺ . For obtaining the function described in <i>parameter 1-75 Start Speed [Hz]</i> and <i>parameter 1-76 Start Current</i> during the start delay time. The motor rotates in the reference direction. If the reference signal equals zero (0), <i>parameter 1-75 Start Speed [Hz]</i> is ignored and the output speed equals zero (0). The output current corresponds to the setting of the start current in <i>parameter 1-76 Start Current</i> .
[5]	VVC ⁺ clockwise	The start speed is calculated automatically. This function uses the start speed in the start delay time only.

1-73 Flying Start		
Option:	Function:	
		<p>NOTICE</p> <p>To obtain the best flying start performance, the advanced motor data, <i>parameter 1-30 Stator Resistance (Rs)</i> to <i>parameter 1-35 Main Reactance (Xh)</i>, must be correct.</p> <p>Catch a motor which is spinning freely due to a mains dropout.</p>
[0]	Disabled	No function.
[1]	Enabled	Enable the frequency converter to catch and control a spinning motor. When <i>parameter 1-73 Flying Start</i> is enabled, <i>parameter 1-71 Start Delay</i> , and <i>parameter 1-72 Start Function</i> have no function.
[2]	Enabled Always	Enable flying start at every start command.
[3]	Enabled Ref. Dir.	Enable the frequency converter to catch and control a spinning motor. The search is performed only in the reference direction.
[4]	Enab. Always Ref. Dir.	Enable flying start at every start command. The search is performed only in the reference direction.

1-75 Start Speed [Hz]		
Range:	Function:	
Size related*	[0 - 500.0 Hz]	This parameter can be used for hoist applications (cone rotor). Set a motor start speed. After the start signal, the output speed leaps to the set value. Set the start function in <i>parameter 1-72 Start Function</i> to [3] Start speed cw, [4] Horizontal operation, or [5] VVC ⁺ clockwise, and set a start delay time in <i>parameter 1-71 Start Delay</i> .

1-76 Start Current		
Range:	Function:	
Size related*	[0 - 1000 A]	Some motors, for example cone rotor motors, need extra current/starting speed to disengage the rotor. To obtain this boost, set the required current in this parameter. Set <i>parameter 1-72 Start Function</i> to [3] Start speed cw or [4] Horizontal operation, and set a start delay time in <i>parameter 1-71 Start Delay</i> .

1-78 Compressor Start Max Speed [Hz]		
Range:	Function:	
0 Hz*	[0 - 500 Hz]	This parameter enables high starting torque. This function ignores current limit and torque limit during start of the motor. The time from the start signal is given until the speed exceeds the speed set in this parameter becomes a start zone. In the start zone, the current limit and motoric torque limit are set to the maximum possible value for the frequency converter/motor combination. The time without protection from the current limit and torque limit must not exceed the value set in <i>parameter 1-79 Compressor Start Max Time to Trip</i> . Otherwise, the frequency converter trips with <i>alarm 18, Start Failed</i> .

1-79 Compressor Start Max Time to Trip		
Range:	Function:	
5 s*	[0 - 10 s]	The time from the start signal is given until the speed exceeds the speed set in <i>parameter 1-78 Compressor Start Max Speed [Hz]</i> must not exceed the time set in this parameter. Otherwise, the frequency converter trips with <i>alarm 18, Start Failed</i> . Any time set in <i>parameter 1-71 Start Delay</i> for use of a start function must be executed within the time limit.

4.2.9 1-8* Stop Adjustments

Parameters for adjusting motor stop settings.

1-80 Function at Stop		
Option:	Function:	
	Select the frequency converter function after a stop command or after the speed is ramped down to the settings in <i>parameter 1-82 Min Speed for Function at Stop [Hz]</i> . Available selections depend on the setting in <i>parameter 1-10 Motor Construction</i> . <ul style="list-style-type: none"> • [0] Asynchron. <ul style="list-style-type: none"> - [0] Coast. - [1] DC hold / Motor Preheat. - [3] Pre-magnetizing. • [1] PM, non salient SPM. • [3] PM, salient IPM. <ul style="list-style-type: none"> - [0] Coast. - [1] DC hold / Motor Preheat. 	
[0]	Coast	Leaves the motor in free mode.
[1]	DC hold / Motor Preheat	Energizes the motor with a DC hold current (see <i>parameter 2-00 DC Hold/Motor Preheat Current</i>).
[3]	Pre-magnetizing	Builds up a magnetic field while the motor is stopped. This allows the motor to produce torque quickly at commands (asynchronous motors only). This premagnetizing function does not help the very first start command. Two different solutions are available to pre-magnetize the machine for the first start command: Solution 1: <ol style="list-style-type: none"> Start the frequency converter with a 0 RPM reference. Wait 2 to 4 rotor time constants (see the equation below) before increasing the speed reference. Solution 2: <ol style="list-style-type: none"> Set <i>parameter 1-71 Start Delay</i> to the premagnetize time (2–4 rotor time constants). Set <i>parameter 1-72 Start Function</i> to [0] DC hold. Set the DC-hold current magnitude (<i>parameter 2-00 DC Hold/Motor Preheat Current</i> to be equal to $I_{pre-mag} = U_{nom}/(1.73 \times X_h)$). Sample rotor time constants= $(X_h+X_2)/(6.3 \times Freq_nom \times R_r)$

1-80 Function at Stop		
Option:	Function:	
	1 kW=0.2 s 10 kW=0.5 s 100 kW=1.7 s	

1-82 Min Speed for Function at Stop [Hz]		
Range:	Function:	
0 Hz*	[0 - 20 Hz]	Set the output frequency at which to activate <i>parameter 1-80 Function at Stop</i> .

1-88 AC Brake Gain		
Range:	Function:	
1.4*	[1.0 - 2.0]	This parameter is used to set AC brake power capability (set ramp-down time when inertia is constant). In cases where the DC-link voltage is not higher than DC-link voltage trip value, the generator torque can be adjusted with this parameter. The higher AC brake gain is, the stronger the brake capability is. Select 1.0 means that there is no AC brake capability. NOTICE If there is continuous generator torque, higher generator torque causes higher motor current, and the motor becomes hot. In this condition, <i>parameter 2-16 AC Brake, Max current</i> can be used to protect the motor from overheating.

4.2.10 1-9* Motor Temperature

Parameters for adjusting temperature protection settings for the motor.

4

1-90 Motor Thermal Protection		
Option:	Function:	
[0] *	No protection	Continuously overloaded motor, when no warning or trip of the frequency converter is required.
[1]	Thermistor warning	Activates a warning when the connected thermistor in the motor reacts to a motor overtemperature.
[2]	Thermistor trip	Stops (trips) the frequency converter when the connected thermistor in the motor reacts to a motor overtemperature. The thermistor cutout value must be >3 kΩ. Integrate a thermistor (PTC sensor) in the motor for winding protection.
[3]	ETR warning 1	Calculates the load and activates a warning in the display when the motor is overloaded. Program a warning signal via 1 of the digital outputs.
[4]	ETR trip 1	Calculates the load and stops (trips) the frequency converter when the motor is overloaded. Program a warning signal via 1 of the digital outputs. The signal appears in the event of a warning and if the frequency converter trips (thermal warning). Once the MOTOR ETR OVER alarm is reported, it can reset immediately.
[22]	ETR Trip - Extended Detection	Calculates the load and stops (trips) the frequency converter when the motor is overloaded. Program a warning signal via 1 of the digital outputs. The signal appears in the event of a warning and if the frequency converter trips (thermal warning). Once the MOTOR ETR OVER alarm is reported, it can only reset after <i>parameter 16-18 Motor Thermal</i> decreases to 0.

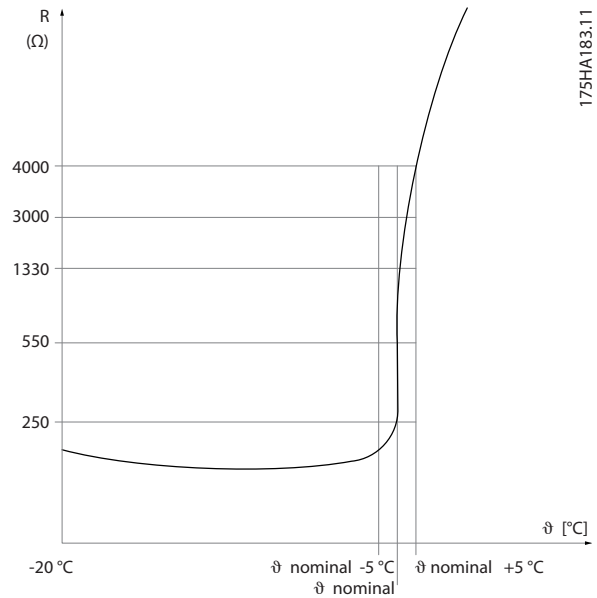

Illustration 4.4 PTC Profile

Using a digital input and 10 V as supply:
Example: The frequency converter trips when the motor temperature is too high.

Parameter set-up:

- Set *parameter 1-90 Motor Thermal Protection* to [2] *Thermistor Trip*.
- Set *parameter 1-93 Thermistor Source* to [6] *Digital Input 33*.

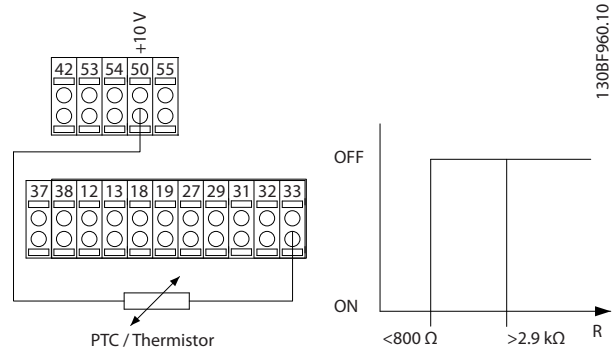
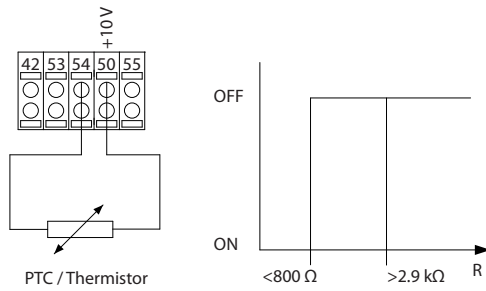

Illustration 4.5 PTC Thermistor Connection - Digital Input

Using an analog input and 10 V as supply:
Example: The frequency converter trips when the motor temperature is too high.

Parameter set-up:

- Set *parameter 1-90 Motor Thermal Protection* to [2] *Thermistor Trip*.
- Set *parameter 1-93 Thermistor Source* to [2] *Analog Input 54*.



130BF694.10

Illustration 4.6 PTC Thermistor Connection - Analog Input

Input digital/analog	Supply voltage	Threshold cutout values
Digital	10 V	<math><800 \Omega - 2.9 \text{ k}\Omega</math>
Analog	10 V	<math><800 \Omega - 2.9 \text{ k}\Omega</math>

Table 4.3 Threshold Cutout Values

NOTICE

Check that the selected supply voltage follows the specification of the used thermistor element.

1-93 Thermistor Source	
Option:	Function:
	<p>NOTICE This parameter cannot be changed while the motor is running.</p> <p>NOTICE Digital input should be set to [0] PNP - Active at 24 V in parameter 5-00 Digital Input Mode.</p> <p>Select the input to which the thermistor (PTC sensor) should be connected. If an analog input in this parameter is set as a source, it cannot be used for other purpose, for example, reference, feedback.</p>
[0] *	None
[1]	Analog Input 53
[2]	Analog Input 54
[3]	Digital input 18
[4]	Digital input 19
[5]	Digital input 32
[6]	Digital input 33

1-93 Thermistor Source	
Option:	Function:
[7]	Digital input 31

4.3 Parameters: 2-** Brakes

4.3.1 2-0* DC Brake

Use this parameter group to configure DC brake and DC hold functions.

2-00 DC Hold/Motor Preheat Current	
Range:	Function:
50 % * [0 - 160 %]	<p>Set the holding current as a percentage of the rated motor current $I_{M,N}$ parameter 1-24 Motor Current. This parameter holds the motor function (holding torque) or pre-heats the motor. This parameter is active if [0] DC hold is selected in parameter 1-72 Start Function, or if [1] DC hold/pre-heat is selected in parameter 1-80 Function at Stop.</p> <p>NOTICE The maximum value depends on the rated motor current. Avoid 100% current for too long. It may damage the motor.</p>

2-01 DC Brake Current	
Range:	Function:
50 %* [0 - 150 %]	<p>NOTICE MOTOR OVERHEATING The maximum value depends on the rated motor current. To avoid motor damage caused by overheating, do not run at 100% for too long.</p> <p>Set current as % of rated motor current, parameter 1-24 Motor Current. When speed is below the limit set in parameter 2-04 DC Brake Cut In Speed, or when the DC-brake inverse function is active (in parameter group 5-1* Digital Inputs set to [5] DC-brake inverse; or via the serial port), a DC-brake current is applied on a stop command. See parameter 2-02 DC Braking Time for duration.</p>

2-02 DC Braking Time	
Range:	Function:
10 s*	[0 - 60 s]
	Set the duration of the DC-brake current set in parameter 2-01 DC Brake Current, once activated.

2-04 DC Brake Cut In Speed		
Range:		Function:
0 Hz*	[0 - 500 Hz]	This parameter is for setting the DC brake cut-in speed at which the DC brake current <i>parameter 2-01 DC Brake Current</i> is to be active, with a stop command.

2-06 Parking Current		
Range:		Function:
100 %*	[0 - 150 %]	Set current as percentage of rated motor current, <i>parameter 1-24 Motor Current</i> .

2-07 Parking Time		
Range:		Function:
3 s*	[0.1 - 60 s]	Set the duration of the parking current set in <i>parameter 2-06 Parking Current</i> , once activated.

4.3.2 2-1* Brake Energy Funct.

Parameter group for selecting dynamic braking parameters. Only valid for frequency converters with brake chopper.

2-10 Brake Function		
Option:		Function:
[0]	Off	No brake resistor is installed.
[1]	Resistor brake	A brake resistor is incorporated in the system for dissipating surplus brake energy as heat. Connecting a brake resistor allows a higher DC-link voltage during braking (generating operation). The brake resistor function is only active in frequency converters with an integral dynamic brake.
[2]	AC brake	Improve braking without using a brake resistor. This parameter controls an overmagnetization of the motor when running with a generative load. This function can improve the OVC function. Increasing the electrical losses in the motor allows the OVC function to increase braking torque without exceeding the voltage limit. NOTICE The AC brake is not as efficient as dynamic braking with resistor. AC brake is for VVC+ mode in both open and closed loop.

2-11 Brake Resistor (ohm)		
Range:		Function:
Size related*	[0 - 6200 Ohm]	Set the brake resistor value in Ω. This value is used for monitoring the power to the brake resistor. <i>Parameter 2-11 Brake Resistor (ohm)</i> is only active in frequency converters with an integral dynamic brake. Use this parameter for values without decimals.

2-12 Brake Power Limit (kW)		
Range:		Function:
Size related*	[0.001 - 2000 kW]	<i>Parameter 2-12 Brake Power Limit (kW)</i> is the expected average power dissipated in the brake resistor over a period of 120 s. It is used as the monitoring limit for <i>parameter 16-33 Brake Energy Average</i> and specifies when a warning/alarm is given. To calculate <i>parameter 2-12 Brake Power Limit (kW)</i> , the following formula can be used. $P_{br,avg}[W] = \frac{U_{br}^2[V] \times t_{br}[s]}{R_{br}[\Omega] \times T_{br}[s]}$ <p>$P_{br,avg}$ is the average power dissipated in the brake resistor. R_{br} is the resistance of the brake resistor. t_{br} is the active braking time within the 120 s period T_{br}. U_{br} is the DC voltage where the brake resistor is active. For T4 units, the DC voltage is 770 V, which can be reduced by <i>parameter 2-14 Brake voltage reduce</i>.</p> <p>NOTICE If R_{br} is not known or if T_{br} is different from 120 s, the practical approach is to run the brake application, read out <i>parameter 16-33 Brake Energy Average</i>, and then enter this value + 20% in <i>parameter 2-12 Brake Power Limit (kW)</i>.</p>

2-14 Brake voltage reduce		
Range:		Function:
0 V*	[0 - 71 V]	Setting this parameter may change the brake resistor (<i>parameter 2-11 Brake Resistor (ohm)</i>).

2-16 AC Brake, Max current		
Range:		Function:
100 %*	[0 - 160 %]	Enter the maximum allowed current when using AC brake to avoid overheating of motor windings. NOTICE Parameter 2-16 AC Brake, Max current is only available for asynchronous motors.

2-17 Over-voltage Control		
Option:		Function:
		Overvoltage control (OVC) reduces the risk of the frequency converter tripping due to an overvoltage on the DC link caused by generative power from the load.
[0] *	Disabled	No OVC required.
[1]	Enabled (not at stop)	Activate OVC except when using a stop signal to stop the frequency converter.
[2]	Enabled	Activate OVC. CAUTION PERSONAL INJURY AND EQUIPMENT DAMAGE Enabling OVC in hoisting applications may lead to personal injuries and equipment damage. <ul style="list-style-type: none"> DO NOT enable OVC in hoisting applications.

2-19 Over-voltage Gain		
Range:		Function:
100 %*	[0 - 200 %]	Select overvoltage gain.

4.3.3 2-2* Mechanical Brake

2-20 Release Brake Current		
Range:		Function:
0 A*	[0 - 100 A]	Set the motor current for release of the mechanical brake when a start condition is present. The upper limit is specified in parameter 16-37 Inv. Max. Current. NOTICE When mechanical brake control output is selected, but no mechanical brake is connected, the function does not work by default setting due to too low motor current.

2-22 Activate Brake Speed [Hz]		
Range:		Function:
0 Hz*	[0 - 400 Hz]	Set the motor frequency for activation of the mechanical brake when a stop condition is present.

2-23 Activate Brake Delay		
Range:		Function:
0 s*	[0 - 5 s]	Enter the brake delay time of the coast after ramp-down time. The shaft is held at 0 speed with full holding torque. Ensure that the mechanical brake has locked the load before the motor enters coast mode.

4.4 Parameters: 3-*** Reference/Ramps

4.4.1 3-0* Reference Limits

Parameters for setting the reference unit, limits, and ranges.

3-00 Reference Range		
Option:	Function:	
[0] *	Min - Max	Select the range of the reference signal and the feedback signal. Signal values can be positive only, or positive and negative.
[1]	-Max - +Max	For both positive and negative values (both directions), relative to <i>parameter 4-10 Motor Speed Direction</i> .

3-01 Reference/Feedback Unit		
Option:	Function:	
[0]	None	
[1]	%	
[2]	RPM	
[3]	Hz	
[4]	Nm	
[5]	PPM	
[10]	1/min	
[12]	Pulse/s	
[20]	l/s	
[21]	l/min	
[22]	l/h	
[23]	m ³ /s	
[24]	m ³ /min	
[25]	m ³ /h	
[30]	kg/s	
[31]	kg/min	
[32]	kg/h	
[33]	t/min	
[34]	t/h	
[40]	m/s	
[41]	m/min	
[45]	m	
[60]	°C	
[70]	mbar	
[71]	bar	
[72]	Pa	
[73]	kPa	
[74]	m WG	
[80]	kW	
[120]	GPM	
[121]	gal/s	
[122]	gal/min	
[123]	gal/h	
[124]	CFM	
[125]	ft ³ /s	
[126]	ft ³ /min	
[127]	ft ³ /h	

3-01 Reference/Feedback Unit		
Option:	Function:	
[130]	lb/s	
[131]	lb/min	
[132]	lb/h	
[140]	ft/s	
[141]	ft/min	
[145]	ft	
[150]	lb ft	
[160]	°F	
[170]	psi	
[171]	lb/in2	
[172]	in WG	
[173]	ft WG	
[180]	HP	

3-02 Minimum Reference		
Range:	Function:	
0 Reference-FeedbackUnit*	[-4999.0 - 4999 ReferenceFeed-backUnit]	<p>Enter the minimum reference. The minimum reference is the lowest value obtainable by summing all references.</p> <p>The minimum reference is active only when <i>parameter 3-00 Reference Range</i> is set to [0] <i>Min.-Max</i>.</p> <p>The minimum reference unit matches:</p> <ul style="list-style-type: none"> The option in <i>parameter 1-00 Configuration Mode</i>. The unit selected in <i>parameter 3-01 Reference/Feedback Unit</i>.

3-03 Maximum Reference		
Range:	Function:	
Size related*	[-4999.0 - 4999 ReferenceFeed-backUnit]	<p>Enter the maximum reference. The maximum reference is the highest value obtainable by summing all references.</p> <p>The maximum reference unit matches:</p> <ul style="list-style-type: none"> The option selected in <i>parameter 1-00 Configuration Mode</i>. The unit selected in <i>parameter 3-00 Reference Range</i>.

3-04 Reference Function		
Option:	Function:	
[0] *	Sum	Sum both external and preset reference sources.
[1]	External/ Preset	Use either the preset or the external reference source. Shift between external and preset via a command or a digital input.

4.4.2 3-1* References

3-10 Preset Reference		
Range:	Function:	
0 %*	[-100 - 100 %]	Enter up to 8 different preset references (0-7) in this parameter, using array programming. For selecting dedicated references, select <i>preset reference bit 0/1/2</i> [16], [17], or [18] for the corresponding digital inputs in <i>parameter group 5-1* Digital Inputs</i> .

3-11 Jog Speed [Hz]		
Range:	Function:	
5 Hz*	[0 - 500.0 Hz]	The jog speed is a fixed output speed at which the frequency converter runs when the jog function is activated. See also <i>parameter 3-80 Jog Ramp Time</i> . The jog speed must not exceed the setting in <i>parameter 4-14 Motor Speed High Limit [Hz]</i> .

3-12 Catch up/slow Down Value		
Range:	Function:	
0 %*	[0 - 100 %]	Enter a percentage value to be either added to or deducted from the actual reference for catching up or slowing down respectively. If [28] <i>Catch up</i> is selected via 1 of the digital inputs (<i>parameter 5-10 Terminal 18 Digital Input to parameter 5-15 Terminal 33 Digital Input</i>), the percentage value is added to the total reference. If [29] <i>Slow down</i> is selected via 1 of the digital inputs (<i>parameter 5-10 Terminal 18 Digital Input to parameter 5-15 Terminal 33 Digital Input</i>), the percentage value is deducted from the total reference.

3-14 Preset Relative Reference		
Range:	Function:	
0 %*	[-100 - 100 %]	The actual reference, X, is increased or decreased with the percentage Y, set in <i>parameter 3-14 Preset Relative Reference</i> . This results in the actual reference Z. Actual reference (X) is the sum of the inputs selected in <i>parameter 3-15 Reference 1 Source</i> , <i>parameter 3-16 Reference 2 Source</i> , <i>parameter 3-17 Reference 3 Source</i> , and <i>parameter 8-02 Control Source</i> .

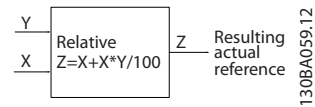

Illustration 4.7 Preset Relative Reference

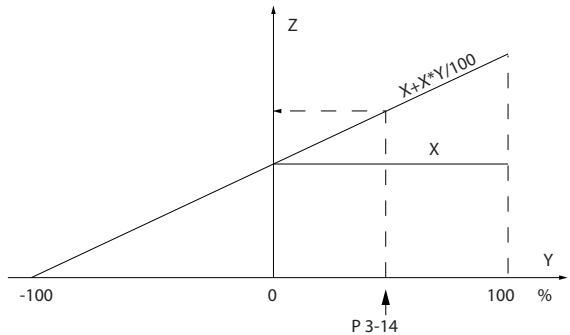

Illustration 4.8 Actual Reference

3-15 Reference 1 Source		
Option:	Function:	
		Select the reference input to be used for the first reference signal. <i>Parameter 3-15 Reference 1 Source</i> , <i>parameter 3-16 Reference 2 Source</i> , and <i>parameter 3-17 Reference 3 Source</i> define up to 3 different reference signals. The sum of these reference signals defines the actual reference.
[0]	No function	
[1] *	Analog Input 53	
[2]	Analog Input 54	
[7]	Frequency input 29	
[8]	Frequency input 33	
[11]	Local bus reference	
[20]	Digital pot.meter	
[32]	Bus PCD	

3-16 Reference 2 Source		
Option:	Function:	
		Select the reference input to be used for the second reference signal. <i>Parameter 3-15 Reference 1 Source, parameter 3-16 Reference 2 Source, and parameter 3-17 Reference 3 Source</i> define up to 3 different reference signals. The sum of these reference signals defines the actual reference.
[0]	No function	
[1]	Analog Input 53	
[2] *	Analog Input 54	
[7]	Frequency input 29	
[8]	Frequency input 33	
[11]	Local bus reference	
[20]	Digital pot.meter	
[32]	Bus PCD	

3-17 Reference 3 Source		
Option:	Function:	
		Select the reference input to be used for the third reference signal. <i>Parameter 3-15 Reference 1 Source, parameter 3-16 Reference 2 Source, and parameter 3-17 Reference 3 Source</i> define up to 3 different reference signals. The sum of these reference signals defines the actual reference.
[0]	No function	
[1]	Analog Input 53	
[2]	Analog Input 54	
[7]	Frequency input 29	
[8]	Frequency input 33	
[11] *	Local bus reference	
[20]	Digital pot.meter	
[32]	Bus PCD	

3-18 Relative Scaling Reference Resource		
Option:	Function:	
		<p>NOTICE This parameter cannot be adjusted while the motor is running.</p> <p>Select a variable value to be added to the fixed value (defined in <i>parameter 3-14 Preset Relative Reference</i>). The sum of the fixed and variable values (labeled Y in <i>Illustration 4.9</i>) is multiplied by the actual reference (labeled X in <i>Illustration 4.9</i>). This product is then added to the actual reference ($X+X*Y/100$) to give the resulting actual reference.</p> <div style="text-align: center;"> </div> <p>Illustration 4.9 Resulting Actual Reference</p>
[0] *	No function	
[1]	Analog Input 53	
[2]	Analog Input 54	
[7]	Frequency input 29	
[8]	Frequency input 33	
[11]	Local bus reference	

4.4.3 3-4* Ramp 1

Configure the ramp parameter, ramping times, for each of the 4 ramps (*parameter group 3-4* Ramp 1, parameter group 3-5* Ramp 2, parameter group 3-6* Ramp 3, and parameter group 3-7* Ramp 4*).

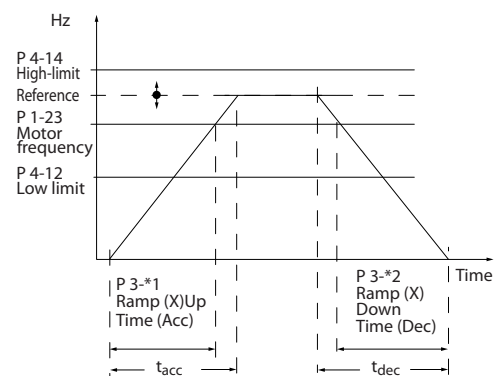

Illustration 4.10 Example of Ramp 1

3-40 Ramp 1 Type		
Option:	Function:	
		Select the ramp type, depending on requirements for acceleration/deceleration. A linear ramp gives constant acceleration during ramping. A sine 2 ramp gives non-linear acceleration.
[0] *	Linear	
[2]	Sine 2 Ramp	(Only be used with speed control mode.) S-ramp based on the values set in <i>parameter 3-41 Ramp 1 Ramp Up Time</i> and <i>parameter 3-42 Ramp 1 Ramp Down Time</i> .

3-41 Ramp 1 Ramp Up Time		
Range:	Function:	
Size related*	[0.01 - 3600 s]	Enter the ramp-up time, that is the acceleration time from 0 Hz to the synchronous motor speed n_s <i>parameter 1-23 Motor Frequency</i> or from 0 NM to the nominal torque if torque configuration modes are selected. It is applicable for Ramp 1 to Ramp 4. Select a ramp-up time such that the output current does not exceed the current limit in <i>parameter 4-18 Current Limit</i> during ramping. See ramp-down time in <i>parameter 3-42 Ramp 1 Ramp Down Time</i> . $Par. 3 - 41 = \frac{t_{acc} [s] \times n_s [Hz]}{ref [Hz]}$

3-42 Ramp 1 Ramp Down Time		
Range:	Function:	
Size related*	[0.01 - 3600 s]	Enter the ramp-down time, that is the deceleration time from the synchronous motor speed n_s to 0 Hz or from the nominal torque to 0 NM if the torque configuration modes are selected. Select a ramp-down time such that no overvoltage occurs in the inverter due to regenerative operation of the motor, and such that the generated current does not exceed the current limit set in <i>parameter 4-18 Current Limit</i> . See ramp-up time in <i>parameter 3-41 Ramp 1 Ramp Up Time</i> . $Par. 3 - 42 = \frac{t_{dec} [s] \times n_s [Hz]}{ref [Hz]}$

4.4.4 3-5* Ramp 2

This parameter group configures ramp 2 parameters.

3-50 Ramp 2 Type		
Option:	Function:	
		Select the ramp type, depending on requirements for acceleration/deceleration. A linear ramp gives constant acceleration during ramping. A sine 2 ramp gives non-linear acceleration.
[0] *	Linear	
[2]	Sine 2 Ramp	S-ramp based on the values set in <i>parameter 3-51 Ramp 2 Ramp Up Time</i> and <i>parameter 3-52 Ramp 2 Ramp Down Time</i> .

3-51 Ramp 2 Ramp Up Time		
Range:	Function:	
Size related*	[0.01 - 3600 s]	Enter the ramp-up time, which is the acceleration time from 0 Hz to the rated motor speed n_s . Select a ramp-up time such that the output current does not exceed the current limit in <i>parameter 4-18 Current Limit</i> during ramping. See ramp-down time in <i>parameter 3-52 Ramp 2 Ramp Down Time</i> . $Par. 3 - 51 = \frac{t_{acc} [s] \times n_s [Hz]}{ref [Hz]}$

3-52 Ramp 2 Ramp Down Time		
Range:	Function:	
Size related*	[0.01 - 3600 s]	Enter the ramp-down time, that is the deceleration time from the rated motor speed n_s to 0 Hz or from the nominal torque to 0 NM if the torque configuration modes are selected. Select a ramp-down time such that no overvoltage arises in the frequency converter due to regenerative operation of the motor, and such that the generated current does not exceed the current limit set in <i>parameter 4-18 Current Limit</i> . See ramp-up time in <i>parameter 3-51 Ramp 2 Ramp Up Time</i> . $Par. 3 - 52 = \frac{t_{dec} [s] \times n_s [Hz]}{ref [Hz]}$

4.4.5 3-6* Ramp 3

This parameter group configures ramp 3 parameters.

3-60 Ramp 3 Type		
Option:	Function:	
		Select the ramp type, depending on requirements for acceleration/deceleration. A linear ramp gives constant acceleration during ramping. An S-ramp gives non-linear acceleration.
[0] *	Linear	
[2]	Sine 2 Ramp	S-ramp based on the values set in <i>parameter 3-61 Ramp 3 Ramp up Time</i> and <i>parameter 3-62 Ramp 3 Ramp down Time</i> .

3-61 Ramp 3 Ramp up Time		
Range:	Function:	
Size related*	[0.01 - 3600 s]	Enter the ramp-up time, which is the acceleration time from 0 Hz to the rated motor speed n_s . Select a ramp-up time such that the output current does not exceed the current limit in <i>parameter 4-18 Current Limit</i> during ramping. See ramp-down time in <i>parameter 3-62 Ramp 3 Ramp down Time</i> .

3-62 Ramp 3 Ramp down Time		
Range:	Function:	
Size related*	[0.01 - 3600 s]	Enter the ramp-down time, which is the deceleration time from the rated motor speed n_s to 0 Hz. Select a ramp-down time such that no overvoltage arises in the inverter due to regenerative operation of the motor, and such that the generated current does not exceed the current limit set in <i>parameter 4-18 Current Limit</i> . See ramp-up time in <i>parameter 3-61 Ramp 3 Ramp up Time</i> . $Par. 3 - 62 = \frac{t_{dec} [s] \times n_s [Hz]}{ref [Hz]}$

4.4.6 3-7* Ramp 4

This parameter group configures ramp 4 parameters.

3-70 Ramp 4 Type		
Option:	Function:	
		Select the ramp type, depending on requirements for acceleration/deceleration. A linear ramp gives constant acceleration during ramping. An S-ramp gives non-linear acceleration.
[0] *	Linear	

3-70 Ramp 4 Type		
Option:	Function:	
[2]	Sine 2 Ramp	S-ramp based on the values set in <i>parameter 3-71 Ramp 4 Ramp up Time</i> and <i>parameter 3-72 Ramp 4 Ramp Down Time</i> .

3-71 Ramp 4 Ramp up Time		
Range:	Function:	
Size related*	[0.01 - 3600 s]	Enter the ramp-up time, which is the acceleration time from 0 Hz to the rated motor speed n_s . Select a ramp-up time such that the output current does not exceed the current limit in <i>parameter 4-18 Current Limit</i> during ramping. See ramp-down time in <i>parameter 3-72 Ramp 4 Ramp Down Time</i> . $Par. 3 - 71 = \frac{t_{acc} [s] \times n_s [Hz]}{ref [Hz]}$

3-72 Ramp 4 Ramp Down Time		
Range:	Function:	
Size related*	[0.01 - 3600 s]	Enter the ramp-down time, which is the deceleration time from the rated motor speed n_s to 0 Hz. Select a ramp-down time such that no overvoltage arises in the inverter due to regenerative operation of the motor, and such that the generated current does not exceed the current limit set in <i>parameter 4-18 Current Limit</i> . See ramp-up time in <i>parameter 3-71 Ramp 4 Ramp up Time</i> . $Par. 3 - 72 = \frac{t_{dec} [s] \times n_s [Hz]}{ref [Hz]}$

4.4.7 3-8* Other Ramps

3-80 Jog Ramp Time		
Range:	Function:	
Size related*	[0.01 - 3600 s]	Enter the jog ramp time, which is the acceleration/deceleration time between 0 Hz and the rated motor frequency n_s . Ensure that the resulting output current required for the given jog ramp time does not exceed the current limit in <i>parameter 4-18 Current Limit</i> . The jog ramp time starts when activating a jog signal via the LCP, a selected digital output, or the serial communication port. When jog state is disabled, the normal ramping times are valid.

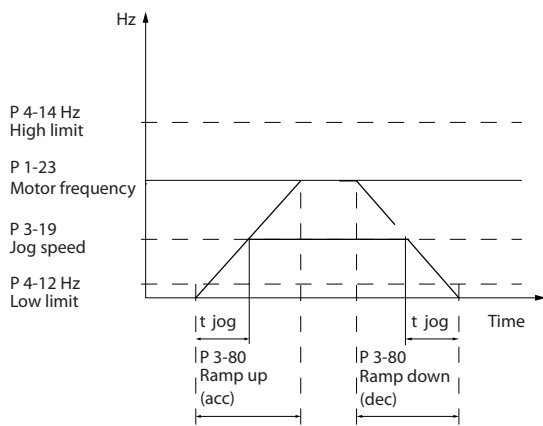

1308D375.11

Illustration 4.11 Jog Ramp Time

4.4.8 3-9* Digital Potentiometer

The digital potentiometer enables increase or decrease of the actual reference by adjusting the set-up of the digital inputs using the functions *Increase*, *Decrease* or *Clear*. To activate the function, at least 1 digital input must be set to *Increase* or *Decrease*.

$$Par. 3-80 = \frac{t_{jog} [s] \times n_s [Hz]}{\Delta jog\ speed (par. 3-19) [Hz]}$$

3-81 Quick Stop Ramp Time		
Range:	Function:	
Size related*	[0.01 - 3600 s]	Enter the quick-stop ramp-down time, which is the deceleration time from the synchronous motor speed to 0 Hz. Ensure that no resulting overvoltage occurs in the inverter due to regenerative operation of the motor required to achieve the given ramp-down time. Ensure also that the generated current required to achieve the given ramp-down time does not exceed the current limit (set in parameter 4-18 Current Limit). Activate quick stop with a signal on a selected digital input, or via the serial communication port.

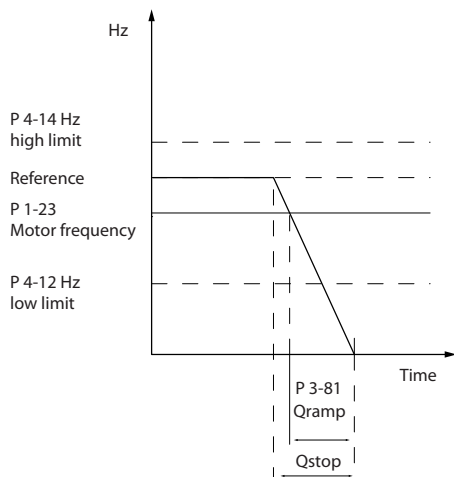

1308D376.11

Illustration 4.12 Quick Stop Ramp Time

3-90 Step Size		
Range:	Function:	
0.10 %*	[0.01 - 200 %]	Enter the increment size required for increase/decrease as a percentage of the synchronous motor speed, n _s . If increase/decrease is activated, the resulting reference is increased/decreased by the amount set in this parameter.

3-92 Power Restore		
Option:	Function:	
[0] *	Off	Reset the digital potentiometer reference to 0% after power-up.
[1]	On	Restore the most recent digital potentiometer reference at power-up.

3-93 Maximum Limit		
Range:	Function:	
100 %*	[-200 - 200 %]	Set the maximum permissible value for the resulting reference. This is recommended if the digital potentiometer is used for fine-tuning of the resulting reference.

3-94 Minimum Limit		
Range:	Function:	
-100 %	[-200 - 200 %]	Set the minimum allowed value for the resulting reference. This is recommended if the digital potentiometer is used for fine-tuning of the resulting reference.

3-95 Ramp Delay		
Range:	Function:	
1000 ms*	[0 - 3600000 ms]	Enter the delay required from activation of the digital potentiometer function until the frequency converter starts to ramp the reference. With a delay of 0 ms, the reference starts to ramp as soon as increase/decrease is activated.

4.5 Parameters: 4-** Limits/Warnings

4.5.1 4-1* Motor Limits

Define torque, current, and speed limits for the motor, and the reaction of the frequency converter when the limits are exceeded.

A limit may generate a message in the display. A warning always generates a message in the display or on the fieldbus. A monitoring function may initiate a warning or a trip, after which the frequency converter stops and generates an alarm message.

4-10 Motor Speed Direction		
Option:	Function:	
[0]	Clockwise	<p>NOTICE</p> <p>The setting in <i>parameter 4-10 Motor Speed Direction</i> has impact on <i>parameter 1-73 Flying Start</i>.</p> <p>Only operation in clockwise direction is allowed.</p>
[2] *	Both directions	Operation in both clockwise and counter-clockwise directions are allowed.

4-12 Motor Speed Low Limit [Hz]		
Range:	Function:	
0 Hz* [0 - 500.0 Hz]	<p>Enter the minimum limit for motor speed. The motor speed low limit can be set to correspond to the minimum output frequency of the motor shaft.</p> <p>The motor speed low limit must not exceed the setting in <i>parameter 4-14 Motor Speed High Limit [Hz]</i>.</p>	

4-14 Motor Speed High Limit [Hz]		
Range:	Function:	
65 Hz* [0.1 - 500 Hz]	<p>NOTICE</p> <p>Maximum output frequency cannot exceed 10% of the inverter switching frequency (<i>parameter 14-01 Switching Frequency</i>).</p> <p>Enter the maximum limit for motor speed. The motor speed high limit can be set to correspond to the manufacturer's recommended maximum of the motor shaft.</p> <p>The motor speed high limit must exceed the value in <i>parameter 4-12 Motor Speed Low Limit [Hz]</i>, and must not exceed the value in <i>parameter 4-19 Max Output Frequency</i>.</p>	

4-16 Torque Limit Motor Mode		
Range:	Function:	
Size related* [0 - 1000 %]	This function limits the torque on the shaft to protect the mechanical installation.	

4-17 Torque Limit Generator Mode		
Range:	Function:	
100 %* [0 - 1000 %]	This function limits the torque on the shaft to protect the mechanical installation.	

4-18 Current Limit		
Range:	Function:	
Size related* [0 - 1000 %]	<p>This is a true current limit function that continues in the oversynchronous range. However, due to field weakening, the motor torque at current limit drops accordingly when the voltage increase stops above the synchronized motor speed.</p>	

4-19 Max Output Frequency		
Range:	Function:	
Size related* [0 - 500 Hz]	<p>NOTICE</p> <p>This parameter cannot be adjusted while the motor is running.</p> <p>NOTICE</p> <p>Maximum output frequency cannot exceed 10% of the inverter switching frequency (<i>parameter 14-01 Switching Frequency</i>).</p> <p>Provide a final limit on the output frequency for improved safety in applications at risk of overspeeding. This limit is final in all configurations (independent of the setting in <i>parameter 1-00 Configuration Mode</i>).</p>	

4.5.2 4-2* Limit Factors

4-20 Torque Limit Factor Source		
Select an analog input for scaling the settings in <i>parameter 4-16 Torque Limit Motor Mode</i> and <i>parameter 4-17 Torque Limit Generator Mode</i> 0–100% (or inverse). The signal levels corresponding to 0% and 100% are defined in the analog input scaling, for example <i>parameter group 6-1* Analog Input 1</i> . This parameter is only active when <i>parameter 1-00 Configuration Mode</i> is set to [0] <i>Open Loop</i> or [1] <i>Speed Closed Loop</i> .		
Option:	Function:	
[0] *	No function	
[2]	Analog in 53	
[4]	Analog in 53 inv	
[6]	Analog in 54	
[8]	Analog in 54 inv	

4-21 Speed Limit Factor Source		
Select an analog input for scaling the settings in <i>parameter 4-19 Max Output Frequency</i> 0–100% (or inverse). The signal levels corresponding to 0% and 100% are defined in the analog input scaling, for example <i>parameter group 6-1* Analog Input 1</i> . This parameter is only active when <i>parameter 1-00 Configuration Mode</i> is in torque mode.		
Option:	Function:	
[0] *	No function	
[2]	Analog in 53	
[4]	Analog in 53 inv	
[6]	Analog in 54	
[8]	Analog in 54 inv	

4-22 Break Away Boost		
Option:	Function:	
[0] *	Off	
[1]	On	The frequency converter provides higher current than normal current levels to enhance breakaway-torque capacity.

4.5.3 4-3* Motor Feedback Monitoring

NOTICE

Warning 61, Feedback error is active as soon as the value in *parameter 4-31 Motor Feedback Speed Error* is exceeded, regardless of the setting in *parameter 4-32 Motor Feedback Loss Timeout*. Alarm 61, Feedback error is related to the motor feedback loss function.

4-30 Motor Feedback Loss Function		
Option:	Function:	
[0]	Disabled	This function is used to monitor consistency in the feedback signal, that is if the feedback signal is available. Select the action of the frequency converter if a feedback fault is detected. The selected action takes place when the feedback signal differs from the output speed by the value set in <i>parameter 4-31 Motor Feedback Speed Error</i> for longer than the value set in <i>parameter 4-32 Motor Feedback Loss Timeout</i> .
[1]	Warning	
[2] *	Trip	
[3]	Jog	
[4]	Freeze Output	
[5]	Max Speed	
[6]	Switch to Open Loop	

4-31 Motor Feedback Speed Error		
Range:	Function:	
20 Hz*	[0 - 50 Hz]	Select the maximum allowed error in speed (output speed versus feedback).

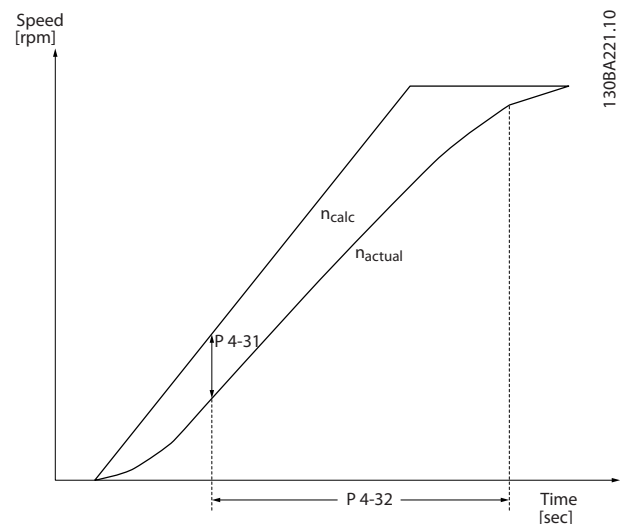

Illustration 4.13 Motor Feedback Speed Error

4-32 Motor Feedback Loss Timeout		
Range:	Function:	
0.05 s*	[0 - 60 s]	Set the timeout value allowing the speed error set in <i>parameter 4-31 Motor Feedback Speed Error</i> to be exceeded before enabling the function selected in <i>parameter 4-30 Motor Feedback Loss Function</i> .

4.5.4 4-4* Adjustable Warnings 2

4-40 Warning Freq. Low		
Range:		Function:
Size related*	[0 - 500 Hz]	Use this parameter for setting a lower limit for the frequency range. When the motor speed drops below this limit, the display reads <i>Speed low</i> . Warning bit 10 is set in <i>parameter 16-94 Ext. Status Word</i> . Output relay can be configured to indicate this warning. LCP warning light is not lit when the limit set is reached. The value must not exceed the setting in <i>parameter 4-41 Warning Freq. High</i> .

4-41 Warning Freq. High		
Range:		Function:
Size related*	[0 - 500 Hz]	Use this parameter for setting a higher limit for the frequency range. When the motor speed exceeds this limit, the display reads <i>Speed high</i> . Warning bit 9 is set in <i>parameter 16-94 Ext. Status Word</i> . Output relay can be configured to indicate this warning. LCP warning light is not lit when the limit set is reached. The value must exceed the value in <i>parameter 4-40 Warning Freq. Low</i> , and must not exceed the value in <i>parameter 4-14 Motor Speed High Limit [Hz]</i> .

4-42 Adjustable Temperature Warning		
Range:		Function:
0*	[0 - 200]	Use this parameter to set the motor temperature limit.

4.5.5 4-5* Adjustable Warnings

Use these parameters to adjust warning limits for current, speed, reference, and feedback.

4-50 Warning Current Low		
Range:		Function:
0 A*	[0 - 194.0 A]	Enter the I_{LOW} value. When the motor current drops below this limit, a bit in the status word is set. This value can also be programmed to produce a signal on the digital output or the relay output.

4-51 Warning Current High		
Range:		Function:
Size related*	[0.0 - 194.0 A]	Enter the I_{HIGH} value. When the motor current exceeds this limit, a bit in the status word is set. This value can also be programmed to produce a signal on the digital output or the relay output.

4-54 Warning Reference Low		
Range:		Function:
-4999*	[-4999 - 4999]	Enter the low reference limit. When the actual reference drops below this limit, the display shows <i>RefLow</i> . Bit 20 is set in <i>parameter 16-94 Ext. Status Word</i> . The output relay or the digital output can be configured to indicate this warning. The LCP warning light is not turned on when this parameter set limit is reached.

4-55 Warning Reference High		
Range:		Function:
4999*	[-4999 - 4999]	Use this parameter to set a high limit for the reference range. When the actual reference exceeds this limit, the display shows <i>RefHigh</i> . Bit 19 is set in <i>parameter 16-94 Ext. Status Word</i> . The output relay or the digital output can be configured to indicate this warning. The LCP warning light is not turned on when this parameter set limit is reached.

4-56 Warning Feedback Low		
Range:		Function:
-4999 ProcessCtrlUnit*	[-4999 - 4999 ProcessCtrlUnit]	Use this parameter to set a low limit for the feedback range. When the feedback drops below this limit, the display shows <i>Feedb Low</i> . Bit 6 is set in <i>parameter 16-94 Ext. Status Word</i> . The output relay or the digital output can be configured to indicate this warning. The LCP warning light is not turned on when this parameter set limit is reached.

4-57 Warning Feedback High		
Range:		Function:
4999 ProcessCtrlUnit*	[-4999 - 4999 ProcessCtrlUnit]	Use this parameter to set a high limit for the feedback range. When the feedback exceeds this limit, the display reads <i>Feedb High</i> . Bit 5 is set in <i>parameter 16-94 Ext. Status Word</i> . The output relay or the digital output can be configured to indicate this warning. The LCP warning light is not turned on when this parameter set limit is reached.

4-58 Missing Motor Phase Function		
Option:		Function:
[0]	Off	No alarm is shown if a missing motor phase occurs.
[1] *	On	An alarm is shown if a missing motor phase occurs.

4.5.6 4-6* Speed Bypass

4-61 Bypass Speed From [Hz]		
Range:		Function:
0 Hz*	[0 - 500 Hz]	Some systems call for avoiding certain output speeds due to resonance problems in the system. Enter the lower limits of the speeds to be avoided. The bypass speed from must not exceed the setting in <i>parameter 4-14 Motor Speed High Limit [Hz]</i> .

4-63 Bypass Speed To [Hz]		
Range:		Function:
0 Hz*	[0 - 500 Hz]	Some systems call for avoiding certain output speeds due to resonance problems in the system. Enter the upper limits of the speeds to be avoided. The bypass speed to must not exceed the setting in <i>parameter 4-14 Motor Speed High Limit [Hz]</i> .

4.6 Parameters: 5-** Digital In/Out

4.6.1 5-0* Digital I/O Mode

Parameters for configuring the input and output using NPN and PNP.

5-00 Digital Input Mode		
Option:		Function:
		Set NPN or PNP mode for digital inputs. NOTICE This parameter cannot be adjusted while the motor runs.
[0] *	PNP	Action on positive directional pulses (0). PNP systems are pulled down to ground (GND).
[1]	NPN	Action on negative directional pulses (1). NPN systems are pulled up to +24 V, internally in the frequency converter.

5-01 Terminal 27 Mode		
Option:		Function:
[0] *	Input	Define terminal 27 as a digital input.
[1]	Output	Define terminal 27 as a digital output.

5-02 Terminal 29 Mode		
Option:		Function:
[0] *	Input	Defines terminal 29 as a digital input.
[1]	Output	Defines terminal 29 as a digital output.

The digital inputs are used for selecting various functions in the frequency converter.

5-10 to 5-16 Digital Inputs

[0]	No operation	No reaction to signals transmitted to the terminal.
[1]	Reset	Resets frequency converter after a TRIP/ALARM. Not all alarms can be reset.
[2]	Coast inverse	Coasting stop, inverted input (NC). The frequency converter leaves the motor in free mode. Logic 0⇒ coasting stop.
[3]	Coast and reset inverse	Reset and coasting stop inverted input (NC). Leaves motor in free mode and resets frequency converter. Logic 0⇒coasting stop. Logic 1 to Logic 0⇒reset.
[4]	Quick stop inverse	Inverted input (NC). Generates a stop in accordance with the quick stop ramp time set in <i>parameter 3-81 Quick Stop Ramp Time</i> . When the motor stops, the shaft is in free mode. Logic 0⇒ Quick-stop.
[5]	DC-brake inverse	Inverted input for DC braking (NC). Stops the motor by energizing it with a DC current for a

		certain time period. See <i>parameter 2-01 DC Brake Current</i> to <i>parameter 2-04 DC Brake Cut In Speed [Hz]</i> . The function is only active when the value in <i>parameter 2-02 DC Braking Time</i> is different from 0. Logic 0=>DC braking.
[6]	Stop inverse	<p>NOTICE When the frequency converter is at the torque limit and has received a stop command, it may not stop by itself. To ensure that the frequency converter stops, configure a digital output to [27] <i>Torque limit and stop</i> and connect this digital output to a digital input that is configured as coast.</p> <p>Stop inverted function. Generates a stop function when the selected terminal goes from logic 1 to logic 0. The stop is performed according to the selected ramp time (<i>parameter 3-42 Ramp 1 Ramp Down Time</i>, <i>parameter 3-52 Ramp 2 Ramp Down Time</i>, <i>parameter 3-62 Ramp 3 Ramp down Time</i>, <i>parameter 3-72 Ramp 4 Ramp Down Time</i>).</p>
[8]	Start	Select start for a start/stop command. Logic 1=start, logic 0=stop.
[9]	Latched start	The motor starts when a pulse is applied for minimum 4 ms. The motor stops when stop commands are given.
[10]	Reversing	Change the direction of motor shaft rotation. Select logic 1 to reverse. The reversing signal only changes the direction of rotation. It does not activate the start function. Select both directions in <i>parameter 4-10 Motor Speed Direction</i> . The function is not active in process closed loop.
[11]	Start reversing	Used for start/stop and for reversing on the same wire. Signals on start are not allowed at the same time.
[12]	Enable start forward	Disengages the counterclockwise movement and allows for the clockwise direction.
[13]	Enable start reverse	Disengages the clockwise movement and allows for the counterclockwise direction.
[14]	Jog	Use to activate jog speed. See <i>parameter 3-11 Jog Speed [Hz]</i> .
[15]	Preset reference on	Shifts between external reference and preset reference. It is assumed that [1] <i>External/preset</i> has been selected in <i>parameter 3-04 Reference Function</i> . Logic 0=external reference active; logic 1=1 of the 8 preset references is active.
[16]	Preset ref bit 0	Preset ref. bits 0, 1, and 2 enable the selection of 1 of the 8 preset references according to <i>Table 4.4</i> .
[17]	Preset ref bit 1	Same as [16] <i>Preset ref bit 0</i> .

[18]	Preset ref bit 2	Same as [16] <i>Preset ref bit 0</i> .
------	------------------	--

Preset ref. bit	2	1	0
Preset ref. 0	0	0	0
Preset ref. 1	0	0	1
Preset ref. 2	0	1	0
Preset ref. 3	0	1	1
Preset ref. 4	1	0	0
Preset ref. 5	1	0	1
Preset ref. 6	1	1	0
Preset ref. 7	1	1	1

Table 4.4 Preset Ref. Bit

[19]	Freeze ref	Freezes the actual reference, which is now the point of enable/condition for [21] <i>Speed up</i> and [22] <i>Speed down</i> to be used. If [21] <i>Speed up</i> or [22] <i>Speed down</i> is used, the speed change always follows ramp 2 (<i>parameter 3-51 Ramp 2 Ramp Up Time</i> and <i>parameter 3-52 Ramp 2 Ramp Down Time</i>) in the range 0– <i>parameter 3-03 Maximum Reference</i> .
[20]	Freeze output	<p>NOTICE When [20] <i>Freeze output</i> is active, the frequency converter cannot be stopped by setting the signal on [8] <i>Start</i> to low. Stop the frequency converter via a terminal programmed for [2] <i>Coasting inverse</i> or [3] <i>Coast and reset, inverse</i>.</p> <p>Freezes the actual motor frequency (Hz), which is now the point of enable/condition for [21] <i>Speed up</i> and [22] <i>Speed down</i> to be used. If [21] <i>Speed up</i> or [22] <i>Speed down</i> is used, the speed change always follows ramp 2 (<i>parameter 3-51 Ramp 2 Ramp Up Time</i> and <i>parameter 3-52 Ramp 2 Ramp Down Time</i>) in the range 0–<i>parameter 1-23 Motor Frequency</i>.</p>
[21]	Speed up	Select [21] <i>Speed up</i> and [22] <i>Speed down</i> if digital control of the up/down speed is needed (motor potentiometer). Activate this function by selecting either [19] <i>Freeze reference</i> or [20] <i>Freeze output</i> . When speed up/down is activated for less than 400 ms, the resulting reference is increased/ decreased by 0.1%. If speed up/down is activated for more than 400 ms, the resulting reference follows the setting in ramping up/down <i>parameter 3-51/ 3-52</i> .

	Shut down	Catch up
Unchanged speed	0	0
Reduced by %-value	1	0
Increased by %-value	0	1
Reduced by %-value	1	1

Table 4.5 Shut Down/Catch Up

[22]	Speed down	Same as [21] Speed up.
[23]	Set-up select bit 0	Select [23] Set-up select bit 0 to select 1 of the 2 set-ups. Set parameter 0-10 Active Set-up to [9] Multi Set-up.
[26]	Precise stop inv.	Precise stop inverse function is available for terminals 18 or 19.
[28]	Catch up	Increases reference value by percentage (relative) set in parameter 3-12 Catch up/slow Down Value.
[29]	Slow down	Reduces reference value by percentage (relative) set in parameter 3-12 Catch up/slow Down Value.
[32]	Pulse input	<p>(Terminal 29 or 33 only) Measures the duration between pulse flanks. This parameter has a higher resolution at lower frequencies, but is not as precise at higher frequencies. This principle has a cut-off frequency, which makes it unsuited for encoders with low resolutions (for example 30 PPR) at low speeds.</p> <p>Illustration 4.14 Duration Between Pulse Flanks</p>
[34]	Ramp bit 0	Enables a selection from the 4 ramps available, according to Table 4.6.
[35]	Ramp bit 1	Same as ramp bit 0.

Preset ramp bit	1	0
Ramp 1	0	0
Ramp 2	0	1
Ramp 3	1	0
Ramp 4	1	1

Table 4.6 Preset Ramp Bits

[45]	Latched start reverse	The motor starts to run reverse when a pulse is applied for minimum 4 ms. The motor stops when stop commands are given.
[51]	External interlock	This function makes it possible to give an external fault to the frequency converter. This fault is treated in the same way as an internally generated alarm.
[55]	DigiPot increase	Increase signal to the digital potentiometer function described in parameter group 3-9* Digital Pot. Meter.

[56]	DigiPot decrease	Decrease signal to the digital potentiometer function described in parameter group 3-9* Digital Pot. Meter.
[57]	DigiPot clear	Clear the digital potentiometer reference described in parameter group 3-9* Digital Pot. Meter.
[60]	Counter A (up)	Input for increment counting in the SLC counter.
[61]	Counter A (down)	Input for decrement counting in the SLC counter.
[62]	Reset Counter A	Input for reset of counter A.
[63]	Counter B (up)	Input for increment counting in the SLC counter.
[64]	Counter B (down)	Input for decrement counting in the SLC counter.
[65]	Reset Counter B	Input for reset of counter B.
[72]	PID error inverse	Inverts the resulting error from the process PID controller. Available only if parameter 1-00 Configuration Mode is set to [6] Surface Winder or [7] Extended PID Speed OL.
[73]	PID reset I-part	Resets the I-part of the process PID controller. Equivalent to parameter 7-40 Process PID I-part Reset. Available only when parameter 1-00 Configuration Mode is set to [6] Surface Winder or [7] Extended PID Speed OL.
[74]	PID enable	This option enables the extended process PID controller. Equivalent to parameter 7-50 Process PID Extended PID. Available only if parameter 1-00 Configuration Mode is set to [7] Extended PID Speed OL.
[150]	Go To Home	The frequency converter moves to the home position.
[151]	Home Ref. Switch	Indicates the status of the home referenced switch. <i>On</i> means that the home position is reached, <i>off</i> means that the home position is not reached.
[155]	HW Limit Positive	The positive hardware position limit is exceeded. This option is active on the falling edge.
[156]	HW Limit Negative	The negative hardware position limit is exceeded. This option is active on the falling edge.
[157]	Pos. Quick Stop Inv	Stops the frequency converter during positioning with the ramp time that is set in parameter 32-81 Motion Ctrl Quick Stop Ramp. This option is only effective when parameter 37-00 Application Mode is set to [2] Position Control.
[160]	Go To Target Pos.	The frequency converter moves to the target position. This option is only effective when parameter 37-00 Application Mode is set to [2] Position Control.
[162]	Pos. Idx Bit0	Position index bit 0. This option is only effective when parameter 37-00 Application Mode is set to [2] Position Control.

[163]	Pos. Idx Bit1	Position index bit 1. This option is only effective when <i>parameter 37-00 Application Mode</i> is set to [2] <i>Position Control</i> .
[164]	Pos. Idx Bit2	Position index bit 2. This option is only effective when <i>parameter 37-00 Application Mode</i> is set to [2] <i>Position Control</i> .
[165]	Core diameter source	The core diameter source. <i>off</i> means core 1 is selected, and <i>on</i> means that core 2 is selected. This option is only effective when <i>parameter 37-00 Application Mode</i> is set to [1] <i>Center winder</i> .
[166]	New diameter select	Configures whether to select partial roll diameter (<i>off</i>) or core diameter (<i>on</i>). This option is only effective when <i>parameter 37-00 Application Mode</i> is set to [1] <i>Center winder</i> .
[167]	Reset diameter	Resets the diameter. This option is only effective when <i>parameter 37-00 Application Mode</i> is set to [1] <i>Center winder</i> .
[168]	Winder jog forward	Enables jog forward during center winding. This option is only effective when <i>parameter 37-00 Application Mode</i> is set to [1] <i>Center winder</i> .
[169]	Winder jog reverse	Enables jog reverse during center winding. This option is only effective when <i>parameter 37-00 Application Mode</i> is set to [1] <i>Center winder</i> .
[170]	Tension on	Enables tension PID control. This option is only effective when <i>parameter 37-00 Application Mode</i> is set to [1] <i>Center winder</i> .

5-10 Terminal 18 Digital Input

Option: **Function:**

[8] *	Start	Functions are described in <i>parameter group 5-1* Digital Inputs</i> .
-------	-------	---

5-11 Terminal 19 Digital Input

Option: **Function:**

[10] *	Reversing	Functions are described in <i>parameter group 5-1* Digital Inputs</i> .
--------	-----------	---

5-12 Terminal 27 Digital Input

Option: **Function:**

[2] *	Coast inverse	Functions are described in <i>parameter group 5-1* Digital Inputs</i> .
-------	---------------	---

5-13 Terminal 29 Digital Input

Option: **Function:**

[14] *	Jog	Functions are described in <i>parameter group 5-1* Digital Inputs</i> .
[32]	Pulse input	

5-14 Terminal 32 Digital Input

Option: **Function:**

[0] *	No operation	Functions are described in <i>parameter group 5-1* Digital Inputs</i> .
[82]	Encoder input B	

5-15 Terminal 33 Digital Input

Option: **Function:**

[0]	No operation	Functions are described in <i>parameter group 5-1* Digital Inputs</i> .
[16] *	Preset ref bit 0	
[32]	Pulse input	
[81]	Encoder input A	

5-16 Terminal 31 Digital Input

Option: **Function:**

[0]	No operation	Functions are described in <i>parameter group 5-1* Digital Inputs</i> .
-----	--------------	---

4.6.2 5-3* Digital Outputs

The 2 solid-state digital outputs are common for terminals 27 and 29. Set the I/O function for terminal 27 in *parameter 5-01 Terminal 27 Mode*, and set the I/O function for terminal 29 in *parameter 5-02 Terminal 29 Mode*.

Terminals 42 and 45 can also be configured as digital outputs.

NOTICE

These parameters cannot be adjusted while the motor is running.

5-30 to 5-31 Digital Outputs

[0]	No operation	Default for all digital outputs and relay outputs.
[1]	Control ready	The control card is ready.
[2]	Drive ready	The frequency converter is ready for operation and applies a supply signal on the control board.
[3]	Drive ready / remote control	The frequency converter is ready for operation and is in auto-on mode.
[4]	Enable / no warning	Ready for operation. No start or stop command is given (start/disable). No warnings are active.
[5]	Running	The motor is running and shaft torque is present.
[6]	Running / no warning	The motor is running and there are no warnings.
[7]	Run in range / no warning	The motor is running within the programmed current and speed ranges set in <i>parameter 4-50 Warning Current Low</i> to <i>parameter 4-51 Warning Current High</i> . There are no warnings.
[8]	Run on reference / no warning	The motor runs at reference speed. No warnings.
[9]	Alarm	An alarm activates the output.
[10]	Alarm or warning	An alarm or a warning activates the output.
[11]	At torque limit	The torque limit set in <i>parameter 4-16 Torque Limit Motor Mode</i> or <i>parameter 4-17 Torque Limit Generator Mode</i> has been exceeded.
[12]	Out of current range	The motor current is outside the range set in <i>parameter 4-18 Current Limit</i> .
[13]	Below current, low	The motor current is lower than set in <i>parameter 4-50 Warning Current Low</i> .
[14]	Above current, high	The motor current is higher than set in <i>parameter 4-51 Warning Current High</i> .
[15]	Out of frequency range	Output frequency is outside the frequency range.

[16]	Below frequency, low	The output speed is lower than the setting in <i>parameter 4-40 Warning Freq. Low</i> .
[17]	Above frequency, high	The output speed is higher than the setting in <i>parameter 4-41 Warning Freq. High</i> .
[18]	Out of feedback range	The feedback is outside the range set in <i>parameter 4-56 Warning Feedback Low</i> and <i>parameter 4-57 Warning Feedback High</i> .
[19]	Below feedback low	The feedback is below the limit set in <i>parameter 4-56 Warning Feedback Low</i> .
[20]	Above feedback high	The feedback is above the limit set in <i>parameter 4-57 Warning Feedback High</i> .
[21]	Thermal warning	The thermal warning turns on when the temperature exceeds the limit in the motor, the frequency converter, the brake resistor, or the thermistor.
[22]	Ready, no thermal warning	The frequency converter is ready for operation, and there is no overtemperature warning.
[23]	Remote, ready, no thermal warning	The frequency converter is ready for operation and is in auto-on mode. There is no overtemperature warning.
[24]	Ready, no overvoltage/undervoltage	The frequency converter is ready for operation and the mains voltage is within the specified voltage range (see <i>General Specifications</i> section in the <i>design guide</i>).
[25]	Reverse	The motor runs (or is ready to run) clockwise when logic=0 and counter-clockwise when logic=1. The output changes as soon as the reversing signal is applied.
[26]	Bus OK	Active communication (no timeout) via the serial communication port.
[27]	Torque limit and stop	Use in performing a coast stop and in torque limit condition. If the frequency converter has received a stop signal and is at the torque limit, the signal is logic 0.
[28]	Brake, no brake warning	The brake is active and there are no warnings.
[29]	Brake ready, no fault	The brake is ready for operation and there are no faults.
[30]	Brake fault (IGBT)	The output is logic 1 when the brake IGBT is short-circuited. Use this function to protect the frequency converter if there is a fault on the brake modules. Use the output/relay to cut out the mains voltage from the frequency converter.
[31]	Relay 123	The relay is activated when [0] <i>Control Word</i> is selected in <i>parameter group 8-** Communications and Options</i> .
[32]	Mechanical brake control	Enables control of an external mechanical brake. See <i>parameter group 2-2* Mechanical Brake</i> for more details.
[36]	Control word bit 11	

[37]	Control word bit 12	
[40]	Out of ref range	This option is active when the actual speed is outside the settings in <i>parameter 4-54 Warning Reference Low</i> to <i>parameter 4-55 Warning Reference High</i> .
[41]	Below reference low	This option is active when the actual speed is below the speed reference setting.
[42]	Above reference high	This option is active when the actual speed is above the speed reference setting.
[45]	Bus Ctrl	Controls output via fieldbus. The state of the output is set in <i>parameter 5-90 Digital & Relay Bus Control</i> . The output state is retained in the event of fieldbus timeout.
[46]	Bus Ctrl On at timeout	Controls output via fieldbus. The state of the output is set in <i>parameter 5-90 Digital & Relay Bus Control</i> . When bus timeout occurs, the output state is set high (On).
[47]	Bus Ctrl Off at timeout	
[55]	Pulse output	
[56]	Heat sink cleaning warning, high	
[60]	Comparator 0	See <i>parameter group 13-1* Comparators</i> . If comparator 0 is evaluated as TRUE, the output goes high. Otherwise, it is low.
[61]	Comparator 1	See <i>parameter group 13-1* Comparators</i> . If comparator 1 is evaluated as TRUE, the output goes high. Otherwise, it is low.
[62]	Comparator 2	See <i>parameter group 13-1* Comparators</i> . If comparator 2 is evaluated as TRUE, the output goes high. Otherwise, it is low.
[63]	Comparator 3	See <i>parameter group 13-1* Comparators</i> . If comparator 3 is evaluated as TRUE, the output goes high. Otherwise, it is low.
[64]	Comparator 4	See <i>parameter group 13-1* Comparators</i> . If comparator 4 is evaluated as TRUE, the output goes high. Otherwise, it is low.
[65]	Comparator 5	See <i>parameter group 13-1* Comparators</i> . If comparator 5 is evaluated as TRUE, the output goes high. Otherwise, it is low.
[70]	Logic Rule 0	See <i>parameter group 13-4* Logic Rules</i> . If logic rule 0 is evaluated as TRUE, the output goes high. Otherwise, it is low.
[71]	Logic Rule 1	See <i>parameter group 13-4* Logic Rules</i> . If logic rule 1 is evaluated as TRUE, the output goes high. Otherwise, it is low.
[72]	Logic Rule 2	See <i>parameter group 13-4* Logic Rules</i> . If logic rule 2 is evaluated as TRUE, the output goes high. Otherwise, it is low.
[73]	Logic Rule 3	See <i>parameter group 13-4* Logic Rules</i> . If logic rule 3 is evaluated as TRUE, the output goes high. Otherwise, it is low.

[74]	Logic Rule 4	See <i>parameter group 13-4* Logic Rules</i> . If logic rule 4 is evaluated as TRUE, the output goes high. Otherwise, it is low.
[75]	Logic Rule 5	See <i>parameter group 13-4* Logic Rules</i> . If logic rule 5 is evaluated as TRUE, the output goes high. Otherwise, it is low.
[80]	SL Digital Output A	See <i>parameter 13-52 SL Controller Action</i> . The output goes high whenever the smart logic action [38] <i>Set dig. out. A high</i> is executed. The output goes low whenever the smart logic action [32] <i>Set dig. out. A low</i> is executed.
[81]	SL Digital Output B	See <i>parameter 13-52 SL Controller Action</i> . The input goes high whenever the smart logic action [39] <i>Set dig. out. B high</i> is executed. The input goes low whenever the smart logic action [33] <i>Set dig. out. B low</i> is executed.
[82]	SL Digital Output C	See <i>parameter 13-52 SL Controller Action</i> . The input goes high whenever the smart logic action [40] <i>Set dig. out. C high</i> is executed. The input goes low whenever the smart logic action [34] <i>Set dig. out. C low</i> is executed.
[83]	SL Digital Output D	See <i>parameter 13-52 SL Controller Action</i> . The input goes high whenever the smart logic action [41] <i>Set dig. out. D high</i> is executed. The input goes low whenever the smart logic action [35] <i>Set dig. out. D low</i> is executed.
[160]	No alarm	The output is high when no alarm is present.
[161]	Running reverse	The output is high when the frequency converter is running counterclockwise (the logical product of the status bits <i>Running AND Reverse</i>).
[165]	Local reference active	
[166]	Remote ref active	
[167]	Start command active	The output is high when there is an active start command, and no stop command is active.
[168]	Drive in hand mode	The output is high when the frequency converter is in hand-on mode.
[169]	Drive in auto mode	The output is high when the frequency converter is in auto-on mode.
[170]	Homing Completed	The homing operation is completed. This option is only effective when <i>parameter 37-00 Application Mode</i> is set to [2] <i>Position Control</i> .
[171]	Target Position Reached	The target position is reached. This option is only effective when <i>parameter 37-00 Application Mode</i> is set to [2] <i>Position Control</i> .
[172]	Position Control Fault	A fault occurred in the positioning process. Refer to <i>parameter 37-18 Pos. Ctrl</i>

5-40 Function Relay		
Option:	Function:	
[17]	Above frequency, high	The frequency is higher than the setting in <i>parameter 4-41 Warning Freq. High</i> .
[18]	Out of feedb. range	The feedback is outside the range set in <i>parameter 4-56 Warning Feedback Low</i> and <i>parameter 4-57 Warning Feedback High</i> .
[19]	Below feedback, low	The feedback is below the limit set in <i>parameter 4-56 Warning Feedback Low</i> .
[20]	Above feedback, high	The feedback is above the limit set in <i>parameter 4-57 Warning Feedback High</i> .
[21]	Thermal warning	Thermal warning turns on when the temperature exceeds the limit within the motor, frequency converter, brake resistor, or connected resistor.
[22]	Ready, no thermal warning	The frequency converter is ready for operation and there is no overtemperature warning.
[23]	Remote,ready,no TW	The frequency converter is ready for operation and is in auto-on mode. There is no overtemperature warning.
[24]	Ready, no over-/under voltage	The frequency converter is ready for operation, and the mains voltage is within the specified voltage range.
[25]	Reverse	The motor runs (or is ready to run) clockwise when logic=0 and counter-clockwise when logic=1. The output changes as soon as the reversing signal is applied.
[26]	Bus OK	Active communication (no timeout) via the serial communication port.
[27]	Torque limit & stop	Use for performing a coasted stop for frequency converter in torque limit condition. If the frequency converter has received a stop signal and is in torque limit, the signal is logic=0.
[28]	Brake, no brake warning	The brake is active and there are no warnings.
[29]	Brake ready, no fault	The brake is ready for operation and there are no faults.
[30]	Brake fault (IGBT)	The output is logic=1 when the brake IGBT is short-circuited. Use this function to protect the frequency converter if there is a fault on the brake module. Use the digital output/relay to cut out the mains voltage from the frequency converter.
[31]	Relay 123	Digital output/relay is activated when <i>[0] Control word</i> is selected in

5-40 Function Relay		
Option:	Function:	
		<i>parameter group 8-** Comm. and Options</i> .
[32]	Mech brake ctrl	Selection of mechanical brake control. When selected parameters in <i>parameter group 2-2* Mechanical Brake</i> are active, the output must be reinforced to carry the current for the coil in the brake. This issue is solved by connecting an external relay to the selected digital output.
[36]	Control word bit 11	Activate relay 1 by a control word from the fieldbus. No other functional impact on the frequency converter. Typical application: Controlling an auxiliary device from a fieldbus. The function is valid when <i>[0] FC Profile</i> is selected in <i>parameter 8-10 Control Word Profile</i> .
[37]	Control word bit 12	Activate relay 2 by a control word from the fieldbus. No other functional impact on the frequency converter. Typical application: Controlling an auxiliary device from a fieldbus. The function is valid when <i>[0] FC Profile</i> is selected in <i>parameter 8-10 Control Word Profile</i> .
[40]	Out of ref range	Active when the actual speed is outside the settings in <i>parameter 4-54 Warning Reference Low</i> and <i>parameter 4-55 Warning Reference High</i> .
[41]	Below reference, low	Active when the actual speed is below the speed reference setting.
[42]	Above ref, high	Active when the actual speed is above the speed reference setting.
[45]	Bus ctrl.	Controls the digital output/relay via bus. The state of the output is set in <i>parameter 5-90 Digital & Relay Bus Control</i> . The output state is retained in the event of a bus timeout.
[46]	Bus control, timeout: On	Controls output via bus. The state of the output is set in <i>parameter 5-90 Digital & Relay Bus Control</i> . When a bus timeout occurs, the output state is set high (on).
[47]	Bus control, timeout: Off	Controls output via bus. The state of the output is set in <i>parameter 5-90 Digital & Relay Bus Control</i> . When a bus timeout occurs, the output state is set low (off).

5-40 Function Relay		
Option:	Function:	
[56]	Heat sink cleaning warning, high	
[60]	Comparator 0	See <i>parameter group 13-1* Smart Logic Control</i> . If comparator 0 in SLC is TRUE, the output goes high. Otherwise, it goes low.
[61]	Comparator 1	See <i>parameter group 13-1* Smart Logic Control</i> . If comparator 1 in SLC is TRUE, the output goes high. Otherwise, it goes low.
[62]	Comparator 2	See <i>parameter group 13-1* Smart Logic Control</i> . If comparator 2 in SLC is TRUE, the output goes high. Otherwise, it goes low.
[63]	Comparator 3	See <i>parameter group 13-1* Smart Logic Control</i> . If comparator 3 in SLC is TRUE, the output goes high. Otherwise, it goes low.
[64]	Comparator 4	See <i>parameter group 13-1* Smart Logic Control</i> . If comparator 4 in SLC is TRUE, the output goes high. Otherwise, it goes low.
[65]	Comparator 5	See <i>parameter group 13-1* Smart Logic Control</i> . If comparator 5 in SLC is TRUE, the output goes high. Otherwise, it goes low.
[70]	Logic rule 0	See <i>parameter group 13-4* Logic Rules</i> . If logic rule 0 in SLC is TRUE, the output goes high. Otherwise, it goes low.
[71]	Logic rule 1	See <i>parameter group 13-4* Logic Rules</i> . If logic rule 1 in SLC is TRUE, the output goes high. Otherwise, it goes low.
[72]	Logic rule 2	See <i>parameter group 13-4* Logic Rules</i> . If logic rule 2 in SLC is TRUE, the output goes high. Otherwise, it goes low.
[73]	Logic rule 3	See <i>parameter group 13-4* Logic Rules</i> . If logic rule 3 in SLC is TRUE, the output goes high. Otherwise, it goes low.
[74]	Logic rule 4	See <i>parameter group 13-4* Logic Rules</i> . If logic rule 4 in SLC is TRUE, the output goes high. Otherwise, it goes low.
[75]	Logic rule 5	See <i>parameter group 13-4* Logic Rules</i> . If logic rule 5 in SLC is TRUE, the

5-40 Function Relay		
Option:	Function:	
		output goes high. Otherwise, it goes low.
[80]	SL digital output A	See <i>parameter 13-52 SL Controller Action</i> . Output A is low on [32] <i>Smart Logic Action</i> . Output A is high on [38] <i>Smart Logic Action</i> .
[81]	SL digital output B	See <i>parameter 13-52 SL Controller Action</i> . Output B is low on [32] <i>Smart Logic Action</i> . Output B is high on [38] <i>Smart Logic Action</i> .
[82]	SL digital output C	See <i>parameter 13-52 SL Controller Action</i> . Output C is low on [32] <i>Smart Logic Action</i> . Output C is high on [38] <i>Smart Logic Action</i> .
[83]	SL digital output D	See <i>parameter 13-52 SL Controller Action</i> . Output D is low on [32] <i>Smart Logic Action</i> . Output D is high on [38] <i>Smart Logic Action</i> .
[160]	No alarm	The output is high when no alarm is present.
[161]	Running reverse	The output is high when the frequency converter is running counterclockwise (the logical product of the status bits <i>Running AND Reverse</i>).
[165]	Local ref active	
[166]	Remote ref active	
[167]	Start command activ	The output is high when there is an active start command, and no stop command is active.
[168]	Drive in hand mode	The output is high when the frequency converter is in hand-on mode.
[169]	Drive in auto mode	The output is high when the frequency converter is in auto-on mode.
[170]	Homing Completed	The homing operation is completed. This option is only effective when <i>parameter 37-00 Application Mode</i> is set to [2] <i>Position Control</i> .
[171]	Target Position Reached	The target position is reached. This option is only effective when <i>parameter 37-00 Application Mode</i> is set to [2] <i>Position Control</i> .
[172]	Position Control Fault	A fault occurred in the positioning process. Refer to <i>parameter 37-18 Pos. Ctrl Fault Reason</i> for details about the fault. This option is only effective when <i>parameter 37-00 Application Mode</i> is set to [2] <i>Position Control</i> .
[173]	Position Mech Brake	Selects mechanical control for positioning. This option is only effective when

5-40 Function Relay		
Option:	Function:	
		<i>parameter 37-00 Application Mode</i> is set to [2] <i>Position Control</i> .
[175]	Running on tension	Indicates whether tension PID control is active (<i>on</i>) or inactive (<i>off</i>). This option is only effective when <i>parameter 37-00 Application Mode</i> is set to [1] <i>Center winder</i> .
[176]	Ready to run	The center winder control is ready to run. This option is only effective when <i>parameter 37-00 Application Mode</i> is set to [1] <i>Center winder</i> .
[193]	Sleep Mode	The frequency converter/system has entered sleep mode. See <i>parameter group 22-4* Sleep Mode</i> .
[194]	Broken Belt Function	A broken belt condition has been detected. See <i>parameter group 22-4* Sleep Mode</i> .

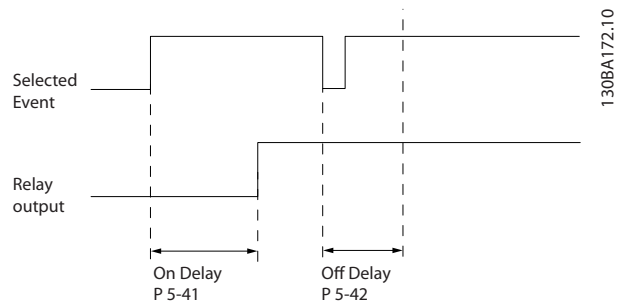

Illustration 4.16 Off Delay, Relay

If the selected event condition changes before the on- or off delay timer expires, the relay output is unaffected.

5-41 On Delay, Relay		
Array [2](Relay 1 [0], Relay 2 [1])		
Range:	Function:	
0.01 s*	[0 - 600 s]	Enter the delay of the relay cutin time. The relay only cuts in if the condition in <i>parameter 5-40 Function Relay</i> is uninterrupted during the specified time.

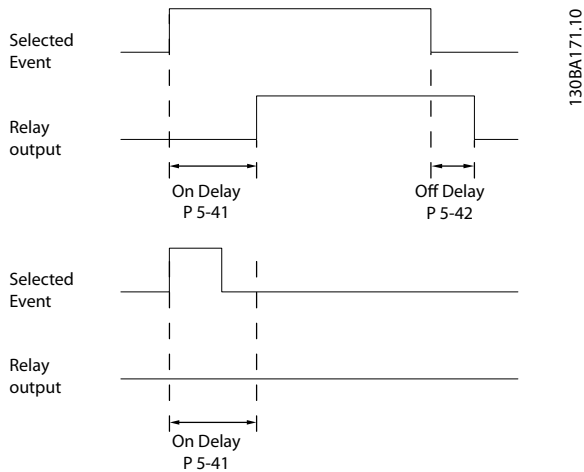

Illustration 4.15 On Delay, Relay

5-42 Off Delay, Relay		
Array[2]: Relay1[0], Relay2[1]		
Range:	Function:	
0.01 s*	[0 - 600 s]	Enter the delay of the relay cutout time.

4.6.4 5-5* Pulse Input

The pulse input parameters are used to define an appropriate window for the impulse reference area by configuring the scaling and filter settings for the pulse inputs. Input terminals 29 or 33 act as frequency reference inputs. Set terminal 29 (*parameter 5-13 Terminal 29 Digital Input*) or terminal 33 (*parameter 5-15 Terminal 33 Digital Input*) to [32] Pulse input. If terminal 29 is used as an input, then set *parameter 5-02 Terminal 29 Mode* to [0] Input.

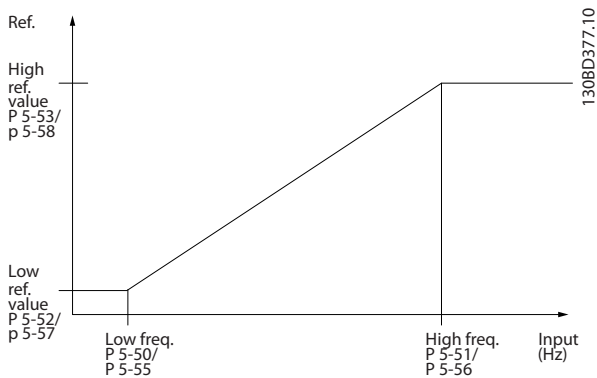

Illustration 4.17 Pulse Input

5-50 Term. 29 Low Frequency		
Range:	Function:	
4 Hz* [4 - 31999 Hz]	Enter the low frequency limit corresponding to the low motor shaft speed (that is low reference value) in <i>parameter 5-52 Term. 29 Low Ref./Feedb. Value</i> . Refer to <i>Illustration 4.17</i> .	

5-51 Term. 29 High Frequency		
Range:	Function:	
32000 Hz* [5 - 32000 Hz]	Enter the high frequency limit corresponding to the high motor shaft speed (which is high reference value) in <i>parameter 5-53 Term. 29 High Ref./Feedb. Value</i> .	

5-52 Term. 29 Low Ref./Feedb. Value		
Range:	Function:	
0* [-4999 - 4999]	Enter the low reference value limit for the motor shaft speed [Hz]. This value is also the lowest feedback value. See also <i>parameter 5-57 Term. 33 Low Ref./Feedb. Value</i> . Set terminal 29 to digital input (<i>parameter 5-02 Terminal 29 Mode = [0] Input</i> and <i>parameter 5-13 Terminal 29 Digital Input = applicable value</i>).	

5-53 Term. 29 High Ref./Feedb. Value		
Range:	Function:	
Size related* [-4999 - 4999]	Enter the high reference value [Hz] for the motor shaft speed, and the high feedback value. See also <i>parameter 5-58 Term. 33 High Ref./Feedb. Value</i> . Select terminal 29 as a digital input (<i>parameter 5-02 Terminal 29 Mode=[0] Input</i> (default) and <i>parameter 5-13 Terminal 29 Digital Input=applicable value</i>).	

5-55 Term. 33 Low Frequency		
Range:	Function:	
4 Hz* [4 - 31999 Hz]	Enter the low frequency corresponding to the low motor shaft speed (which is low reference value) in <i>parameter 5-57 Term. 33 Low Ref./Feedb. Value</i> .	

5-56 Term. 33 High Frequency		
Range:	Function:	
32000 Hz* [5 - 32000 Hz]	Enter the high frequency corresponding to the high motor shaft speed (that is high reference value) in <i>parameter 5-58 Term. 33 High Ref./Feedb. Value</i> .	

5-57 Term. 33 Low Ref./Feedb. Value		
Range:	Function:	
0* [-4999 - 4999]	Enter the low reference value [Hz] for the motor shaft speed. This value is also the low feedback value. See also <i>parameter 5-52 Term. 29 Low Ref./Feedb. Value</i> .	

5-58 Term. 33 High Ref./Feedb. Value		
Range:	Function:	
Size related* [-4999 - 4999]	Enter the high reference value [Hz] for the motor shaft speed. See also <i>parameter 5-53 Term. 29 High Ref./Feedb. Value</i> .	

4.6.5 5-6* Pulse Outputs

NOTICE

These parameters cannot be adjusted while the motor is running.

Use these parameters to configure pulse outputs with their functions and scaling. Terminal 27 and 29 are allocated to pulse output via *parameter 5-01 Terminal 27 Mode* and *parameter 5-02 Terminal 29 Mode*.

4

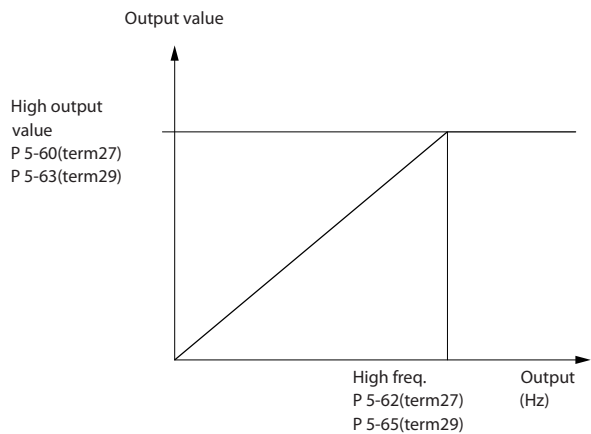

Illustration 4.18 Configuration of Pulse Outputs

5-60 Terminal 27 Pulse Output Variable		
Option:	Function:	
[0] *	No operation	
[45]	Bus ctrl.	
[48]	Bus ctrl., timeout	
[100]	Output frequency	
[101]	Reference	
[102]	Process Feedback	
[103]	Motor Current	
[104]	Torque rel to limit	
[105]	Torq relate to rated	
[106]	Power	
[107]	Speed	
[109]	Max Out Freq	
[113]	PID Clamped Output	

5-62 Pulse Output Max Freq 27		
Range:	Function:	
5000 Hz* [4 - 32000 Hz]	Set the maximum frequency for terminal 27, corresponding to the output variable selected in <i>parameter 5-60 Terminal 27 Pulse Output Variable</i> .	

5-63 Terminal 29 Pulse Output Variable		
Option:	Function:	
[0] *	No operation	
[45]	Bus ctrl.	
[48]	Bus ctrl., timeout	
[100]	Output frequency	
[101]	Reference	
[102]	Process Feedback	
[103]	Motor Current	
[104]	Torque rel to limit	
[105]	Torq relate to rated	
[106]	Power	
[107]	Speed	
[109]	Max Out Freq	
[113]	PID Clamped Output	

5-65 Pulse Output Max Freq 29		
Range:	Function:	
5000 Hz* [4 - 32000 Hz]	Set the maximum frequency for terminal 29 corresponding to the output variable set in <i>parameter 5-63 Terminal 29 Pulse Output Variable</i> .	

4.6.6 5-7* 24 V Encoder Input

Connect the 24 V encoder to terminal 12 (24 V DC supply), terminal 32 (channel A), terminal 33 (channel B), and terminal 20 (GND). The digital inputs 32/33 are active for encoder inputs when [1] 24 V encoder is selected in *parameter 7-00 Speed PID Feedback Source*. The encoder is a dual channel (A and B) 24 V type. Maximum input frequency: 32 kHz.

Encoder connection to the frequency converter
24 V incremental encoder. Maximum cable length 5 m (16.4 ft).

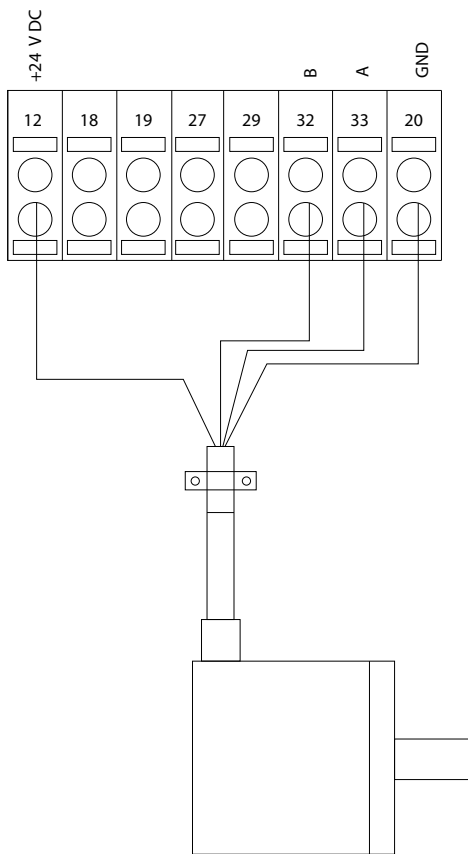

130BD366.12

Illustration 4.19 24 V or 10-30 V Encoder Connection

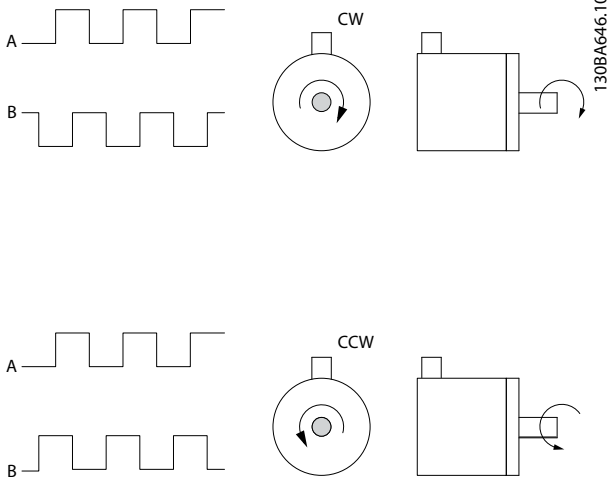

130BA646.10

Illustration 4.20 Encoder Rotation Direction

5-70 Term 32/33 Pulses Per Revolution		
Range:	Function:	
1024*	[1 - 4096]	Set the encoder pulses per revolution on the motor shaft. Read the correct value from the encoder.

5-71 Term 32/33 Encoder Direction		
Option:	Function:	
	NOTICE This parameter cannot be adjusted while the motor is running. Change the detected encoder rotation direction without changing the wiring to the encoder.	
[0] *	Clockwise	Set channel A 90° (electrical degrees) behind channel B after clockwise rotation of the encoder shaft.
[1]	Counter clockwise	Set channel A 90° (electrical degrees) ahead of channel B after clockwise rotation of the encoder shaft.

4

4.6.7 5-9* Bus Controlled

This parameter group selects digital and relay outputs via a fieldbus setting.

5-90 Digital & Relay Bus Control		
Range:	Function:	
0*	[0 - 0xFFFFFFFF]	This parameter holds the state of the bus-controlled digital outputs and relays. A logical 1 indicates that the output is high or active. A logical 0 indicates that the output is low or inactive.

Bit 0	Digital Output Terminal 27
Bit 1	Digital Output Terminal 29
Bit 2-3	Reserved
Bit 4	Relay 1 output terminal
Bit 6-23	Reserved
Bit 24	Terminal 42 digital output
Bit 26-31	Reserved

Table 4.7 Bit Functions

5-93 Pulse Out 27 Bus Control		
Range:		Function:
0 %*	[0 - 100 %]	Set the output frequency transferred to the output terminal 27 when the terminal is configured as <i>[45] Bus Controlled</i> in parameter 5-60 Terminal 27 Pulse Output Variable.

5-94 Pulse Out 27 Timeout Preset		
Range:		Function:
0 %*	[0 - 100 %]	Set the output frequency transferred to the output terminal 27 when the terminal is configured as <i>[48] Bus Ctrl Timeout</i> in parameter 5-60 Terminal 27 Pulse Output Variable and a timeout is detected.

5-95 Pulse Out 29 Bus Control		
Range:		Function:
0 %*	[0 - 100 %]	Set the output frequency transferred to the output terminal 29 when the terminal is configured as <i>[45] Bus Controlled</i> in parameter 5-63 Terminal 29 Pulse Output Variable.

5-96 Pulse Out 29 Timeout Preset		
Range:		Function:
0 %*	[0 - 100 %]	Set the output frequency transferred to the output terminal 29 when the terminal is configured as <i>[48] Bus Ctrl Timeout</i> in parameter 5-63 Terminal 29 Pulse Output Variable, and a timeout is detected.

4.7 Parameters: 6-** Analog In/Out

Parameter group for setting up the analog I/O configuration and the digital output.

The frequency converter provides 2 analog inputs:

- Terminal 53.
- Terminal 54.

The analog inputs can be freely allocated to either voltage (0–10 V) or current input (0/4–20 mA).

4.7.1 6-0* Analog I/O Mode

6-00 Live Zero Timeout Time		
Range:	Function:	
10 s*	[1 - 99 s]	Enter the timeout time.

6-01 Live Zero Timeout Function		
Option:	Function:	
	Select the timeout function. The function set in <i>parameter 6-01 Live Zero Timeout Function</i> is activated if the input signal on terminal 53 or 54 is below 50% of the value in <i>parameter 6-10 Terminal 53 Low Voltage</i> , <i>parameter 6-12 Terminal 53 Low Current</i> , <i>parameter 6-20 Terminal 54 Low Voltage</i> , or <i>parameter 6-22 Terminal 54 Low Current</i> for a time period defined in <i>parameter 6-00 Live Zero Timeout Time</i> .	
[0] *	Off	
[1]	Freeze output	
[2]	Stop	
[3]	Jogging	
[4]	Max. speed	
[5]	Stop and trip	

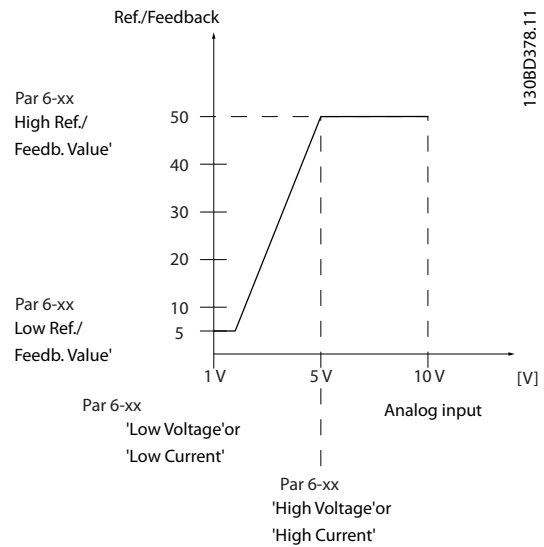

Illustration 4.21 Timeout Function

4.7.2 6-1* Analog Input 53

Parameters for configuring the scaling and limits for analog input 53 (terminal 53).

6-10 Terminal 53 Low Voltage		
Range:	Function:	
0.07 V*	[0 - 10 V]	Enter the voltage (V) that corresponds to <i>parameter 6-14 Terminal 53 Low Ref./Feedb. Value</i> . To activate <i>parameter 6-01 Live Zero Timeout Function</i> , set the value at >1 V.

6-11 Terminal 53 High Voltage		
Range:	Function:	
10 V*	[0 - 10 V]	Enter the voltage (V) that corresponds to the high reference value (set in <i>parameter 6-15 Terminal 53 High Ref./Feedb. Value</i>).

6-12 Terminal 53 Low Current		
Range:	Function:	
4 mA*	[0 - 20 mA]	Enter the low current value. This reference signal corresponds to the low reference/feedback value that is set in <i>parameter 6-14 Terminal 53 Low Ref./Feedb. Value</i> . To activate <i>parameter 6-01 Live Zero Timeout Function</i> , set the value to >2 mA.

6-13 Terminal 53 High Current		
Range:	Function:	
20 mA*	[0 - 20 mA]	Enter the high current value corresponding to the high reference/feedback set in <i>parameter 6-15 Terminal 53 High Ref./Feedb. Value</i> .

6-14 Terminal 53 Low Ref./Feedb. Value		
Range:		Function:
0*	[-4999 - 4999]	Enter the reference or feedback value that corresponds to the voltage or current set in <i>parameter 6-10 Terminal 53 Low Voltage</i> to <i>parameter 6-12 Terminal 53 Low Current</i> .

6-15 Terminal 53 High Ref./Feedb. Value		
Range:		Function:
Size related*	[-4999 - 4999]	Enter the reference or feedback value that corresponds to the voltage or current set in <i>parameter 6-11 Terminal 53 High Voltage</i> to <i>parameter 6-13 Terminal 53 High Current</i> .

6-16 Terminal 53 Filter Time Constant		
Range:		Function:
0.01 s*	[0.01 - 10 s]	Enter the time constant. This constant is a first-order digital low-pass filter time constant for suppressing electrical noise in terminal 53. A high time constant value improves dampening, but also increases the time delay through the filter.

6-19 Terminal 53 mode		
Option:		Function:
		Select whether terminal 53 is used for current or voltage input.
[0]	Current mode	
[1] *	Voltage mode	

4.7.3 6-2* Analog Input 54

Parameters for configuring the scaling and limits for analog input 54 (terminal 54).

6-20 Terminal 54 Low Voltage		
Range:		Function:
0.07 V*	[0 - 10 V]	Enter the voltage (V) that corresponds to the low reference value (set in <i>parameter 6-24 Terminal 54 Low Ref./Feedb. Value</i>). To activate <i>parameter 6-01 Live Zero Timeout Function</i> , set the value at >1 V.

6-21 Terminal 54 High Voltage		
Range:		Function:
10 V*	[0 - 10 V]	Enter the voltage (V) that corresponds to the high reference value (set in <i>parameter 6-25 Terminal 54 High Ref./Feedb. Value</i>).

6-22 Terminal 54 Low Current		
Range:		Function:
4 mA*	[0 - 20 mA]	Enter the low current value. This reference signal corresponds to the low reference/feedback value set in <i>parameter 6-24 Terminal 54 Low Ref./Feedb. Value</i> . To activate the live zero timeout function in <i>parameter 6-01 Live Zero Timeout Function</i> , set the value to >2 mA.

6-23 Terminal 54 High Current		
Range:		Function:
20 mA*	[0 - 20 mA]	Enter the high current value corresponding to the high reference/feedback value set in <i>parameter 6-25 Terminal 54 High Ref./Feedb. Value</i> .

6-24 Terminal 54 Low Ref./Feedb. Value		
Range:		Function:
0*	[-4999 - 4999]	Enter the reference or feedback value that corresponds to the voltage or current set in <i>parameter 6-21 Terminal 54 High Voltage/parameter 6-22 Terminal 54 Low Current</i> .

6-25 Terminal 54 High Ref./Feedb. Value		
Range:		Function:
Size related*	[-4999 - 4999]	Enter the reference or feedback value that corresponds to the voltage or current set in <i>parameter 6-21 Terminal 54 High Voltage/parameter 6-23 Terminal 54 High Current</i> .

6-26 Terminal 54 Filter Time Constant		
Range:		Function:
0.01 s*	[0.01 - 10 s]	Enter the time constant, which is a first-order digital low-pass filter time constant for suppressing electrical noise in terminal 54. A high time constant value improves dampening, but also increases the time delay through the filter.

6-29 Terminal 54 mode		
Option:		Function:
		Select if terminal 54 is used for current input or voltage input.
[0]	Current mode	
[1] *	Voltage mode	

4.7.4 6-7* Analog/Digital Output 45

Parameters for configuring the scaling and limits for analog/digital output terminal 45. Analog outputs are current outputs: 0/4–20 mA. Resolution on analog output is 12 bit. Analog output terminals can also be set up as digital output.

6-70 Terminal 45 Mode		
Option:	Function:	
		Set terminal 45 to act as analog output or as digital output.
[0] *	0-20 mA	
[1]	4-20 mA	
[2]	Digital Output	

6-71 Terminal 45 Analog Output		
Option:	Function:	
[0] *	No operation	
[100]	Output frequency	0–100 Hz
[101]	Reference	Min _{Ref} –Max _{Ref}
[102]	Process Feedback	Min _{FB} –Max _{FB}
[103]	Motor Current	0–I _{max}
[104]	Torque rel to limit	
[105]	Torq relate to rated	
[106]	Power	0–P _{nom}
[107]	Speed	
[111]	Speed Feedback	
[113]	PID Clamped Output	
[139]	Bus Control	0–100%
[143]	Ext. CL 1	
[162]	Tapered tension set point	
[254]	DC Link Voltage	

6-72 Terminal 45 Digital Output		
Option:	Function:	
		Select the function of terminal 45 as a digital current output. See also <i>parameter 6-70 Terminal 45 Mode</i> . See <i>chapter 4.6.2 5-3* Digital Outputs</i> for each options and descriptions.
[0] *	No operation	
[198]	Drive Bypass	

6-73 Terminal 45 Output Min Scale		
Range:	Function:	
0 %*	[0 - 200 %]	Scale for the minimum output (0 or 4 mA) of the analog signal at terminal 45. Set the value to be the percentage of the full range of the variable selected in <i>parameter 6-71 Terminal 45 Analog Output</i> .

6-74 Terminal 45 Output Max Scale		
Range:	Function:	
100 %*	[0 - 200 %]	Scale for the maximum output (20 mA) of the analog signal at terminal 45. Set the value to be the percentage of the full range of the variable selected in <i>parameter 6-71 Terminal 45 Analog Output</i> .

6-76 Terminal 45 Output Bus Control		
Range:	Function:	
0*	[0 - 16384]	Holds the level of analog output if controlled by bus. This parameter is N2 format.

4.7.5 6-9* Analog/Digital Output 42

Parameters for configuring the limits for analog/digital output terminal 42. Analog outputs are current outputs: 0/4–20 mA. Resolution on analog outputs is 12 bit. Analog output terminals can also be set up as digital output.

6-90 Terminal 42 Mode		
Option:	Function:	
		Set terminal 42 to act as analog output or as digital output.
[0] *	0-20 mA	
[1]	4-20 mA	
[2]	Digital Output	

6-91 Terminal 42 Analog Output		
Option:	Function:	
[0] *	No operation	
[100]	Output frequency	
[101]	Reference	
[102]	Process Feedback	
[103]	Motor Current	
[104]	Torque rel to limit	
[105]	Torq relate to rated	
[106]	Power	
[107]	Speed	
[111]	Speed Feedback	
[113]	PID Clamped Output	
[139]	Bus Control	
[143]	Ext. CL 1	
[162]	Tapered tension set point	
[254]	DC Link Voltage	

6-92 Terminal 42 Digital Output		
Option:	Function:	
		See <i>chapter 4.6.2 5-3* Digital Outputs</i> for each options and descriptions.
[0] *	No operation	
[198]	Drive Bypass	

6-93 Terminal 42 Output Min Scale		
Range:	Function:	
0 %* [0 - 200 %]	Scale for the minimum output (0 mA or 4 mA) of the analog signal at terminal 42. Set the value to be the percentage of the full range of the variable selected in <i>parameter 6-91 Terminal 42 Analog Output</i> .	

6-94 Terminal 42 Output Max Scale		
Range:	Function:	
100 %* [0 - 200 %]	Scale for maximum output (20 mA) of the scaling at terminal 42. Set the value to be the percentage of the full range of the variable selected in <i>parameter 6-91 Terminal 42 Analog Output</i> .	
<p>Current (mA)</p> <p>20</p> <p>0/4</p> <p>0% Analog output Min Scale par. 6-93</p> <p>Analog Output Max Scale par. 6-94</p> <p>100% Variable for output example: Power</p> <p>130BB772.10</p>		
Illustration 4.22 Output Scale versus Current		

6-96 Terminal 42 Output Bus Control		
Range:	Function:	
0* [0 - 16384]	Hold the analog output at terminal 42 if controlled by bus. This parameter is N2 format.	

4.8 Parameters: 7-* Controllers

4.8.1 7-0* Speed PID Ctrl.

7-00 Speed PID Feedback Source		
Option:	Function:	
	<p>NOTICE</p> <p>This parameter cannot be changed while the motor is running.</p> <p>Select feedback source for Speed CL Control.</p>	
[1]	24V encoder	
[2]	MCB 102	
[3]	MCB 103	
[6]	Analog Input 53	
[7]	Analog Input 54	
[8]	Frequency input 29	
[9]	Frequency input 33	

7-00 Speed PID Feedback Source		
Option:	Function:	
[20] *	None	

7-02 Speed PID Proportional Gain		
Range:	Function:	
0.015* [0 - 1]	Enter the speed controller proportional gain. The proportional gain amplifies the error (that is the deviation between the feedback signal and the setpoint). This parameter is used with <i>parameter 1-00 Configuration Mode [1] Speed closed loop control</i> . Quick control is obtained at high amplification. However, if the amplification is too high, the process may become unstable.	

7-03 Speed PID Integral Time		
Range:	Function:	
8 ms* [2 - 20000 ms]	Enter the speed controller integral time, which determines the time the internal PID control takes to correct errors. The greater the error, the more quickly the gain increases. The integral time causes a delay of the signal, and therefore a dampening effect, and can be used to eliminate steady-state speed error. Obtain quick control through a short integral time, though if the integral time is too short, the process becomes unstable. An excessively long integral time disables the integral action, leading to major deviations from the required reference, since the process regulator takes too long to regulate errors. This parameter is used with <i>[1] Speed closed loop control set in parameter 1-00 Configuration Mode</i> .	

7-04 Speed PID Differentiation Time		
Range:	Function:	
30 ms* [0 - 200 ms]	Enter the speed controller differentiation time. The differentiator does not react to constant error. It provides gain proportional to the rate of change of the speed feedback. The quicker the error changes, the stronger the gain from the differentiator. The gain is proportional with the speed at which errors change. Setting this parameter to 0 disables the differentiator. This parameter is used with <i>parameter 1-00 Configuration Mode [1] Speed closed loop control</i> .	

7-05 Speed PID Diff. Gain Limit		
Range:	Function:	
5* [1 - 20]	Set a limit for the gain provided by the differentiator. Since the differential gain increases at higher frequencies, limiting the gain may be useful. For example, set up a pure D-link at low frequencies and a constant D-link at higher frequencies. This parameter is used with <i>parameter 1-00 Configuration Mode [1] Speed closed loop control</i> .	

7-06 Speed PID Lowpass Filter Time		Function:										
Range:	[1 - 6000 ms]											
10 ms*		<p>NOTICE Severe filtering can be detrimental to dynamic performance.</p> <p>Set a time constant for the speed control low-pass filter. The low-pass filter improves steady-state performance and dampens oscillations on the feedback signal. This parameter is used with <i>parameter 1-00 Configuration Mode [1] Speed closed loop</i> or <i>[2] Torque closed loop</i>. This parameter is useful if there is a great amount of noise in the system, see <i>Illustration 4.23</i>. For example, if a time constant (τ) of 100 ms is programmed, the cutoff frequency for the low-pass filter is $1/0.1=10$ RAD/s., corresponding to $(10/2 \times \pi)=1.6$ Hz. The PID regulator only regulates a feedback signal that varies by a frequency of less than 1.6 Hz. If the feedback signal varies by a higher frequency than 1.6 Hz, the PID regulator does not react.</p> <p>Practical settings of <i>parameter 7-06 Speed PID Lowpass Filter Time</i> taken from the number of pulses per revolutions from encoder:</p> <table border="1"> <thead> <tr> <th>Encoder PPR</th> <th>Parameter 7-06 Speed PID Lowpass Filter Time</th> </tr> </thead> <tbody> <tr> <td>512</td> <td>10 ms</td> </tr> <tr> <td>1024</td> <td>5 ms</td> </tr> <tr> <td>2048</td> <td>2 ms</td> </tr> <tr> <td>4096</td> <td>1 ms</td> </tr> </tbody> </table>	Encoder PPR	Parameter 7-06 Speed PID Lowpass Filter Time	512	10 ms	1024	5 ms	2048	2 ms	4096	1 ms
Encoder PPR	Parameter 7-06 Speed PID Lowpass Filter Time											
512	10 ms											
1024	5 ms											
2048	2 ms											
4096	1 ms											

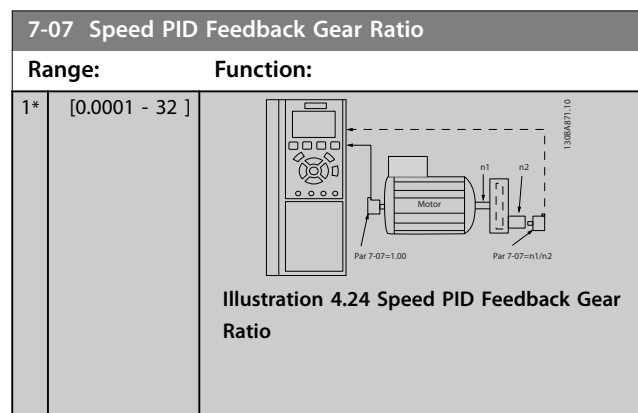
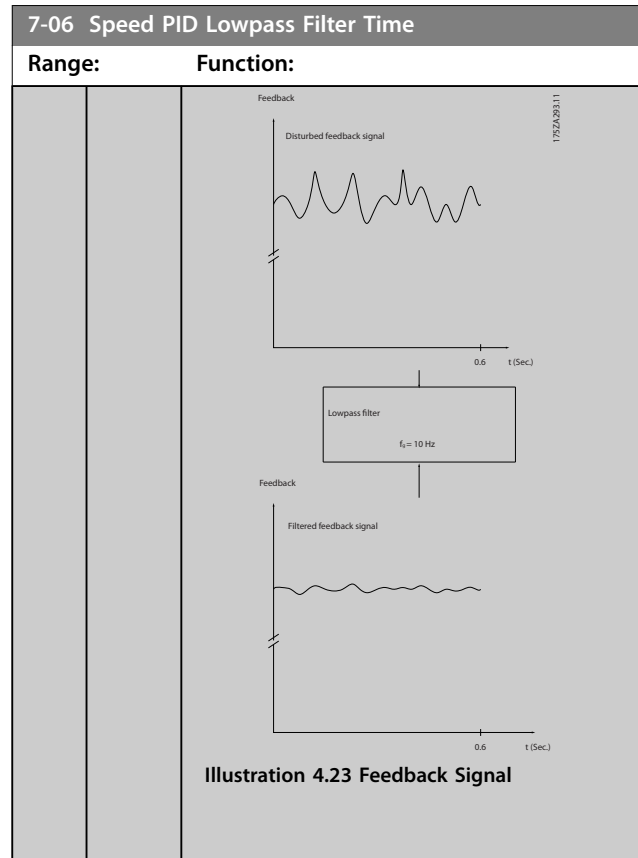

7-08 Speed PID Feed Forward Factor		Function:
Range:	[0 - 500 %]	
0 %*		The reference signal bypasses the speed controller by the amount specified. This feature increases the dynamic performance of the speed control loop.

4.8.2 7-1* Torque PI Control

Parameters for configuring the torque PI control.

7-12 Torque PID Proportional Gain		
Range:	Function:	
100 %*	[0 - 500 %]	Enter the proportional gain value for the torque controller. Selection of a high value makes the controller react faster. Too high a setting leads to controller instability.

7-13 Torque PID Integration Time		
Range:	Function:	
0.020 s*	[0.002 - 2 s]	Enter the integration time for the torque controller. The lower the integration time, the faster the controller reacts. However, too low a setting leads to controller instability.

4.8.3 7-2* Process Ctrl. Feedb.

Select the feedback sources for the process PID control, and how this feedback should be handled.

7-20 Process CL Feedback 1 Resource		
Option:	Function:	
		The effective feedback signal is made up of the sum of up to 2 different input signals. Select which input is treated as the source of the first of these signals. The 2 nd input signal is defined in <i>parameter 7-22 Process CL Feedback 2 Resource</i> .
[0] *	No function	
[1]	Analog Input 53	
[2]	Analog Input 54	
[3]	Frequency input 29	
[4]	Frequency input 33	

7-22 Process CL Feedback 2 Resource		
Option:	Function:	
		The effective feedback signal is made up of the sum of up to 2 different input signals. Select which input is treated as the source of the 2 nd of these signals. The 1 st input signal is defined in <i>parameter 7-20 Process CL Feedback 1 Resource</i> .
[0] *	No function	
[1]	Analog Input 53	
[2]	Analog Input 54	
[3]	Frequency input 29	

7-22 Process CL Feedback 2 Resource		
Option:	Function:	
[4]	Frequency input 33	

4.8.4 7-3* Process PID Ctrl.

7-30 Process PID Normal/ Inverse Control		
Option:	Function:	
		Normal and inverse controls are implemented by introducing a difference between the reference signal and the feedback signal.
[0] *	Normal	Set process control to increase the output frequency.
[1]	Inverse	Set process control to decrease the output frequency.

7-31 Process PID Anti Windup		
Option:	Function:	
[0]	Off	Continue regulation of an error even when the output frequency cannot be increased or decreased.
[1] *	On	Cease regulation of an error when the output frequency can no longer be adjusted.

7-32 Process PID Start Speed		
Range:	Function:	
0 RPM*	[0 - 6000 RPM]	Enter the motor speed to be attained as a start signal for commencement of PID control. When the power is switched on, the frequency converter starts to ramp and then operates under speed open-loop control. When the process PID start speed is reached, the frequency converter changes to process PID control.

7-33 Process PID Proportional Gain		
Range:	Function:	
0.01*	[0 - 10]	Enter the PID proportional gain. The proportional gain multiplies the error between the setpoint and the feedback signal.

7-34 Process PID Integral Time		
Range:	Function:	
9999 s*	[0.10 - 9999 s]	Enter the PID integral time. The integrator provides an increasing gain at a constant error between the setpoint and the feedback signal. The integral time is the time needed by the integrator to reach the same gain as the proportional gain.

7-35 Process PID Differentiation Time		
Range:	Function:	
0 s* [0 - 20 s]	Enter the PID differentiation time. The differentiator does not react to a constant error, but provides a gain only when the error changes. The shorter the PID differentiation time, the stronger the gain from the differentiator.	

7-36 Process PID Diff. Gain Limit		
Range:	Function:	
5* [1 - 50]	Enter a limit for the differentiator gain. If there is no limit, the differentiator gain increases when there are fast changes. To obtain a pure differentiator gain at slow changes and a constant differentiator gain where fast changes occur, limit the differentiator gain.	

7-38 Process PID Feed Forward Factor		
Range:	Function:	
0 %* [0 - 200 %]	Enter the PID feed forward (FF) factor. The FF factor sends a constant fraction of the reference signal to bypass the PID control, so the PID control only affects the remaining fraction of the control signal. Any change to this parameter affects the motor speed. When the FF factor is activated, it provides less overshoot, and high dynamics when changing the setpoint. <i>Parameter 7-38 Process PID Feed Forward Factor is active when parameter 1-00 Configuration Mode is set to [3] Process.</i>	

7-39 On Reference Bandwidth		
Range:	Function:	
5 %* [0 - 200 %]	Enter the on-reference bandwidth. When the PID control error (the difference between the reference and the feedback) is less than the value of this parameter, the on-reference status bit is 1.	

4.8.5 7-4* Advanced Process PID Ctrl.

This parameter group is only used if *parameter 1-00 Configuration Mode* is set to [7] *Extended PID speed CL*.

7-40 Process PID I-part Reset		
Option:	Function:	
[0] * No		
[1] Yes	Select [1] Yes to reset the I-part of the process PID controller. The selection automatically returns to [0] No. Resetting the I-part makes it possible to start from a well-defined point after changing something in the process, for example changing a textile roll.	

7-41 Process PID Output Neg. Clamp		
Range:	Function:	
-100 %* [-100 - 100 %]	Enter a negative limit for the process PID controller output.	

7-42 Process PID Output Pos. Clamp		
Range:	Function:	
100 %* [-100 - 100 %]	Enter a positive limit for the process PID controller output.	

7-43 Process PID Gain Scale at Min. Ref.		
Range:	Function:	
100 %* [0 - 100 %]	Enter a scaling percentage to apply to the process PID output when operating at the minimum reference. The scaling percentage is adjusted linearly between the scale at minimum reference (<i>parameter 7-43 Process PID Gain Scale at Min. Ref.</i>) and the scale at maximum reference (<i>parameter 7-44 Process PID Gain Scale at Max. Ref.</i>).	

7-44 Process PID Gain Scale at Max. Ref.		
Range:	Function:	
100 %* [0 - 100 %]	Enter a scaling percentage to apply to the process PID output when operating at the maximum reference. The scaling percentage is adjusted linearly between the scale at minimum reference (<i>parameter 7-43 Process PID Gain Scale at Min. Ref.</i>) and the scale at maximum reference (<i>parameter 7-44 Process PID Gain Scale at Max. Ref.</i>).	

7-45 Process PID Feed Fwd Resource		
Option:	Function:	
		Select which frequency converter input is used as the feed forward factor. The FF factor is added directly to the output of the PID controller. This parameter can increase dynamic performance. The feed forward set from bus should be in N2 format.
[0] *	No function	
[1]	Analog Input 53	
[2]	Analog Input 54	
[7]	Frequency input 29	
[8]	Frequency input 33	
[11]	Local bus reference	
[32]	Bus PCD	

7-46 Process PID Feed Fwd Normal/ Inv. Ctrl.		
Option:	Function:	
[0] *	Normal	Select [0] <i>Normal</i> to set the feed-forward factor to treat the FF resource as a positive value.
[1]	Inverse	Select [1] <i>Inverse</i> to treat the feed-forward resource as a negative value.

7-48 PCD Feed Forward		
Range:	Function:	
0*	[0 - 65535]	Readout parameter where the bus <i>parameter 7-45 Process PID Feed Fwd Resource [32]</i> can be read. The feed forward set from bus should be in N2 format.

7-49 Process PID Output Normal/ Inv. Ctrl.		
Option:	Function:	
[0] *	Normal	Select [0] <i>Normal</i> to use the resulting output from the process PID controller as is.
[1]	Inverse	Select [1] <i>Inverse</i> to invert the resulting output from the process PID controller. This operation is performed after the feed-forward factor is applied.

4.8.6 7-5* Ext. Process PID Ctrl.

This parameter group is only used if *parameter 1-00 Configuration Mode* is set to [7] *Extended PID speed CL*.

7-50 Process PID Extended PID		
Option:	Function:	
[0]	Disabled	Disable the extended parts of the process PID controller.
[1] *	Enabled	Enable the extended parts of the PID controller.

7-51 Process PID Feed Fwd Gain		
Range:	Function:	
1*	[0 - 100]	The feed forward is used to obtain the gain, based on a well-known signal available. The PID controller then only takes care of the smaller part of the control, necessary because of unknown characters. The standard feed-forward factor in <i>parameter 7-38 Process PID Feed Forward Factor</i> is always related to the reference whereas <i>parameter 7-51 Process PID Feed Fwd Gain</i> has more options. In winder applications, the feed-forward factor is typically the line speed of the system.

7-52 Process PID Feed Fwd Ramp up		
Range:	Function:	
0.01 s*	[0.01 - 100 s]	Control dynamics of the feed-forward signal when ramping up.

7-53 Process PID Feed Fwd Ramp down		
Range:	Function:	
0.01 s*	[0.01 - 100 s]	Control the dynamics of the feed-forward signal when ramping down.

7-56 Process PID Ref. Filter Time		
Range:	Function:	
0.001 s*	[0.001 - 1 s]	Set a time constant for the reference first-order low-pass filter. The low-pass filter improves steady-state performance and dampens oscillations on the reference/ feedback signals. However, severe filtering can be detrimental to dynamic performance.

7-57 Process PID Fb. Filter Time		
Range:	Function:	
0.001 s*	[0.001 - 1 s]	Set a time constant for the feedback first-order low-pass filter. The low-pass filter improves steady-state performance and dampens oscillations on the reference/ feedback signals. However, severe filtering can be detrimental to dynamic performance.

4.8.7 7-6* Feedback Conversion

Use the parameter group to configure conversions for feedback signals.

7-60 Feedback 1 Conversion		
Select a conversion for the feedback 1 signal. Select [0] <i>Linear</i> to leave the feedback signal unchanged.		
Option:		Function:
[0] *	Linear	
[1]	Square root	

7-62 Feedback 2 Conversion		
Select a conversion for the feedback 2 signal. Select [0] <i>Linear</i> to leave the feedback signal unchanged.		
Option:		Function:
[0] *	Linear	
[1]	Square root	

4.9 Parameters: 8-** Communications and Options

4.9.1 8-0* General Settings

8-01 Control Site		
Option:		Function:
		The setting in this parameter overrides the settings in <i>parameter 8-50 Coasting Select</i> to <i>parameter 8-56 Preset Reference Select</i> .
[0] *	Digital and ctrl.word	Control by using both digital input and control word.
[1]	Digital only	Control by using digital inputs only.
[2]	Controlword only	Control by using control word only.

8-02 Control Source		
Option:		Function:
		Select the source of the control word.
[0]	None	
[1]	FC Port	
[3]	Option A	PROFIBUS and PROFINET.

8-03 Control Timeout Time		
Range:		Function:
1 s*	[0.1 - 6000 s]	Enter the maximum time expected to pass between the reception of 2 consecutive telegrams. If this time is exceeded, it indicates that the serial communication has stopped. The function that is selected in <i>parameter 8-04 Control Timeout Function</i> is then carried out.

8-04 Control Timeout Function		
Select the timeout function. The timeout function activates when the control word fails to be updated within the time period specified in <i>parameter 8-03 Control Word Timeout Time</i> .		
Option:		Function:
[0] *	Off	Resume control via fieldbus (fieldbus or standard), using the most recent control word.
[1]	Freeze output	Freeze output frequency until communication resumes.
[2]	Stop	Stop with auto restart until communication resumes.
[3]	Jogging	Run the motor at jog frequency until communication resumes.
[4]	Max. speed	Run the motor at maximum frequency until communication resumes.
[5]	Stop and trip	Stop the motor and trip, then reset the frequency converter to restart: <ul style="list-style-type: none"> Via the fieldbus. Via [Reset]. Via a digital input.

8-07 Diagnosis Trigger		
Option:		Function:
[0] *	Disable	Send no extended diagnosis data (EDD).
[1]	Trigger on alarms	Send EDD upon alarms.
[2]	Trigger alarm/warn.	Send EDD upon alarms or warnings in <i>parameter 16-90 Alarm Word</i> , <i>parameter 9-53 Profibus Warning Word</i> , or <i>parameter 16-92 Warning Word</i> .

4.9.2 8-1* Ctrl. Word Settings

8-10 Control Word Profile		
Select the interpretation of the control and status words corresponding to the installed fieldbus. Only the selections valid for the installed fieldbus are visible in the LCP display.		
Option:		Function:
[0] *	FC profile	
[1]	PROFIdrive profile	

8-14 Configurable Control Word CTW		
Option:		Function:
[0]	None	
[1] *	Profile default	
[2]	CTW Valid, active low	
[4]	PID error inverse	
[5]	PID reset I part	
[6]	PID enable	

8-19 Product Code		
Range:		Function:
Size related*	[0 - 2147483647]	Select 0 to read out the actual fieldbus product code according to the mounted fieldbus option. Select 1 to read out the actual vendor ID.

8-36 Maximum Response Delay		
Range:		Function:
Size related*	[0.1 - 10.0 s]	Specify the maximum allowed delay time between receiving a request and transmitting the response. If this time is exceeded, no response is returned.

4.9.3 8-3* FC Port Settings

8-30 Protocol		
Option:		Function:
		Select the protocol for the integrated RS485 port.
[0] *	FC	Communication according to the FC protocol.
[2]	Modbus RTU	Communication according to the Modbus RTU protocol.

8-31 Address		
Range:		Function:
1*	[0 - 247]	Enter the address for the RS485 port. Valid range: 1–126 for FC-bus, or 1–247 for Modbus.

8-32 Baud Rate		
Option:		Function:
		Select the baud rate for the RS485 port.
[0]	2400 Baud	
[1]	4800 Baud	
[2]	9600 Baud	
[3]	19200 Baud	
[4]	38400 Baud	
[5]	57600 Baud	
[6]	76800 Baud	
[7]	115200 Baud	

8-33 Parity / Stop Bits		
Option:		Function:
[0] *	Even Parity, 1 Stop Bit	
[1]	Odd Parity, 1 Stop Bit	
[2]	No Parity, 1 Stop Bit	
[3]	No Parity, 2 Stop Bits	

8-35 Minimum Response Delay		
Range:		Function:
0.01 s*	[0.0010 - 0.5 s]	Specify the minimum delay time between receiving a request and transmitting a response. This is used for overcoming modem turn-around delays.

4.9.4 8-4* FC MC Protocol Set

8-42 PCD Write Configuration

Select the parameters to be assigned to the PCD's telegrams. The number of available PCDs depends on the telegram type. The values in the PCDs are then written to the selected parameters as data values.

Enter up to 16 different preset mapping 0–15 in this parameter, using array programming. If this parameter is active, addresses 2810–2825 represent values of the 16 parameters. If this parameter is not active, addresses 2810 and 2811 are used as input-data-drive control word and bus reference. Addresses 2812–2825 are reserved.

Option:	Function:	
[0]	None	
[1]	[302] Minimum Reference	
[2]	[303] Maximum Reference	
[3]	[341] Ramp 1 Ramp up time	
[4]	[342] Ramp 1 Ramp down time	
[5]	[351] Ramp 2 Ramp up time	
[6]	[352] Ramp 2 Ramp down time	
[7]	[380] Jog Ramp Time	
[8]	[381] Quick Stop Time	
[9]	[412] Motor Speed Low Limit [Hz]	
[10]	[414] Motor Speed High Limit [Hz]	
[11]	[590] Digital & Relay Bus Control	
[12]	[676] Terminal45 Output Bus Control	
[13]	[696] Terminal 42 Output Bus Control	
[15]	FC Port CTW	
[16]	FC Port REF	
[18]	[311] Jog Speed [Hz]	

8-43 PCD Read Configuration		
<p>Select the parameters to be assigned to the PCDs of the telegrams. The number of available PCDs depends on the telegram type. PCDs contain the actual data values of the selected parameters.</p> <p>Enter up to 16 different preset mapping (0-15) in this parameter, using array programming. If this parameter is active, addresses from 2910 to 2925 represent values of the 16 parameters. If this parameter is not active, addresses 2910 and 2911 are used as status word register and main actual value. Addresses from 2912 to 2925 are reserved.</p>		
Option:	Function:	
[0]	None	
[1]	[1500] Operation Hours	
[2]	[1501] Running Hours	
[3]	[1502] kWh Counter	
[4]	[1600] Control Word	
[5]	[1601] Reference [Unit]	
[6]	[1602] Reference %	
[7]	[1603] Status Word	
[8]	[1605] Main Actual Value [%]	
[9]	[1609] Custom Readout	
[10]	[1610] Power [kW]	
[11]	[1611] Power [hp]	
[12]	[1612] Motor Voltage	
[13]	[1613] Frequency	
[14]	[1614] Motor Current	
[15]	[1615] Frequency [%]	
[16]	[1616] Torque [Nm]	
[17]	[1618] Motor Thermal	
[18]	[1630] DC Link Voltage	
[19]	[1634] Heatsink Temp.	
[20]	[1635] Inverter Thermal	
[21]	[1638] SL Controller State	
[22]	[1650] External Reference	
[23]	[1652] Feedback [Unit]	
[24]	[1660] Digital Input 18,19,27,33	
[25]	[1661] Terminal 53 Switch Setting	
[26]	[1662] Analog input 53	
[27]	[1663] Terminal 54 Switch Setting	
[28]	[1664] Analog input 54	
[29]	[1665] Analog output 42 [mA]	
[30]	[1671] Relay output	
[31]	[1672] Counter A	
[32]	[1673] Counter B	
[33]	[1690] Alarm Word	
[34]	[1692] Warning Word	
[35]	[1694] Ext. Status Word	
[38]	[1622] Torque [%]	
[41]	[1657] Feedback [RPM]	

8-43 PCD Read Configuration		
<p>Select the parameters to be assigned to the PCDs of the telegrams. The number of available PCDs depends on the telegram type. PCDs contain the actual data values of the selected parameters.</p> <p>Enter up to 16 different preset mapping (0-15) in this parameter, using array programming. If this parameter is active, addresses from 2910 to 2925 represent values of the 16 parameters. If this parameter is not active, addresses 2910 and 2911 are used as status word register and main actual value. Addresses from 2912 to 2925 are reserved.</p>		
Option:	Function:	
[42]	[1679] Analog Output 45 [mA]	

4.9.5 8-5* Digital/Bus

Parameters for configuring the control word merging.

NOTICE

These parameters are active only when parameter 8-01 Control Site is set to [0] Digital and control word.

8-50 Coasting Select		
Option:	Function:	
		Select control of the coasting function via the terminals (digital input) and/or via the bus.
[0]	Digital input	Activate coasting command via a digital input.
[1]	Bus	Activate coasting command via the serial communication port or fieldbus option.
[2]	Logic AND	Activate coasting command via the fieldbus/serial communication port and 1 extra digital input.
[3] *	Logic OR	Activate coasting command via the fieldbus/serial communication port or via 1 of the digital inputs.

8-51 Quick Stop Select		
Option:	Function:	
[0]	Digital input	Activate quick stop command via a digital input.
[1]	Bus	Activate quick stop command via the serial communication port or fieldbus option.
[2]	Logic AND	Activate quick stop command via the fieldbus/serial communication port and additionally via 1 of the digital inputs.
[3] *	Logic OR	Activate quick stop command via the fieldbus/serial communication port or via 1 of the digital inputs.

8-52 DC Brake Select		
Option:	Function:	
		Select control of the DC brake via the terminals (digital input) and/or via the fieldbus. NOTICE When <i>parameter 1-10 Motor Construction</i> is set to [1] <i>PM non-salient SPM</i> , only selection [0] <i>Digital input</i> is available.
[0]	Digital input	Activate DC brake command via a digital input.
[1]	Bus	Activate DC brake command via the serial communication port or fieldbus option.
[2]	Logic AND	Activate DC brake command via the fieldbus/serial communication port and additionally via 1 of the digital inputs.
[3] *	Logic OR	Activate DC brake command via the fieldbus/serial communication port or via 1 of the digital inputs.

8-53 Start Select		
Select the trigger for the start function.		
Option:	Function:	
[0]	Digital input	A digital input triggers the start function.
[1]	Bus	A serial communication port or the fieldbus triggers the start function.
[2]	Logic AND	The fieldbus/serial communication port and a digital input trigger the start function.
[3] *	Logic OR	The fieldbus/serial communication port or a digital input triggers the start function.

8-54 Reversing Select		
Option:	Function:	
		Select the trigger for the reversing function.
[0]	Digital input	A digital input triggers the reversing function.
[1]	Bus	A serial communication port or the fieldbus triggers the reversing function.
[2]	Logic AND	The fieldbus/serial communication port and a digital input trigger the reversing function.
[3] *	Logic OR	The fieldbus/serial communication port or a digital input triggers the reversing function.

8-55 Set-up Select		
Select the trigger for the set-up selection.		
Option:	Function:	
[0]	Digital input	A digital input triggers the set-up selection.
[1]	Bus	A serial communication port or the fieldbus triggers the set-up selection.

8-55 Set-up Select		
Select the trigger for the set-up selection.		
Option:	Function:	
[2]	Logic AND	The fieldbus/serial communication port and a digital input trigger the set-up selection.
[3] *	Logic OR	The fieldbus/serial communication port or a digital input triggers the set-up selection.

8-56 Preset Reference Select		
Option:	Function:	
		Select the trigger for the preset reference selection.
[0]	Digital input	A digital input triggers the preset reference selection.
[1]	Bus	A serial communication port or the fieldbus triggers the preset reference selection.
[2]	Logic AND	The fieldbus/serial communication port and a digital input trigger the preset reference selection.
[3] *	Logic OR	The fieldbus/serial communication port or a digital input triggers the preset reference selection.

8-57 Profdrive OFF2 Select		
Select control of the frequency converter OFF2 selection via the terminals (digital input) and/or via the fieldbus. This parameter is active only when <i>parameter 8-01 Control Site</i> is set to [0] <i>Digital and ctrl. word</i> and <i>parameter 8-10 Control Word Profile</i> is set to [1] <i>Profdrive profile</i> .		
Option:	Function:	
[0]	Digital input	
[1]	Bus	
[2]	Logic AND	
[3] *	Logic OR	

8-58 Profdrive OFF3 Select		
Select control of the frequency converter OFF3 selection via the terminals (digital input) and/or via the fieldbus. This parameter is active only when <i>parameter 8-01 Control Site</i> is set to [0] <i>Digital and ctrl. word</i> , and <i>parameter 8-10 Control Word Profile</i> is set to [1] <i>Profdrive profile</i> .		
Option:	Function:	
[0]	Digital input	
[1]	Bus	
[2]	Logic AND	
[3] *	Logic OR	

4.9.6 8-7* Protocol SW Version

8-79 Protocol Firmware version		
Range:		Function:
Size related*	[0 - 65535]	Firmware revision: FC is in index 0; Modbus is in index 1; indexes 2-4 are reserved.

4.9.7 8-8* FC Port Diagnostics

These parameters are used for monitoring the bus communication via the frequency converter port.

8-80 Bus Message Count		
Range:		Function:
0*	[0 - 4294967295]	This parameter shows the number of valid telegrams detected on the bus.

8-81 Bus Error Count		
Range:		Function:
0*	[0 - 4294967295]	This parameter shows the number of telegrams with faults (for example CRC faults) detected on the bus.

8-82 Slave Messages Rcvd		
Range:		Function:
0*	[0 - 4294967295]	This parameter shows the number of valid telegrams sent by the frequency converter to the slave.

8-83 Slave Error Count		
Range:		Function:
0*	[0 - 4294967295]	This parameter shows the number of error telegrams, which could not be executed by the frequency converter.

8-84 Slave Messages Sent		
Range:		Function:
0*	[0 - 4294967295]	This parameter shows the number of messages sent from the slave.

8-85 Slave Timeout Errors		
Range:		Function:
0*	[0 - 4294967295]	This parameter shows the number of slave timeout errors.

8-88 Reset FC port Diagnostics		
Option:		Function:
[0] *	Do not reset	Do not reset all FC port diagnostic counters.
[1]	Reset counter	Reset all FC port diagnostic counters.

4.9.8 8-9* Bus Feedback

Use the parameter group to configure the bus feedback.

8-90 Bus Jog 1 Speed		
Range:		Function:
100 RPM*	[0 - 1500 RPM]	Enter the jog speed. This is a fixed jog speed activated via the serial port or fieldbus option.

8-91 Bus Jog 2 Speed		
Range:		Function:
200 RPM*	[0 - 1500 RPM]	Enter the jog speed. This value is a fixed jog speed activated via the serial port or fieldbus option.

4.10 Parameters: 9-** PROFIdrive

For more information about PROFIBUS parameter descriptions, see the *VLT® AutomationDrive FC 360 PROFIBUS DP Programming Guide*.

For more information about PROFINET parameter descriptions, see the *VLT® AutomationDrive FC 360 PROFINET Programming Guide*.

9-00 Setpoint		
Range:	Function:	
0* [0 - 65535]	This parameter receives cyclic reference from a master class 2. If the control priority is set to master class 2, the reference for the frequency converter is taken from this parameter, whereas the cyclic reference is ignored.	

9-07 Actual Value		
Range:	Function:	
0* [0 - 65535]	This parameter delivers the MAV for a master class 2. The parameter is valid if the control priority is set to master class 2.	

9-15 PCD Write Configuration
 Select the parameters to be assigned to PCD 3–10 of the telegrams. The number of available PCDs depends on the telegram type. Values in PCD 3–10 are written to the selected parameters as data. For standard PROFIBUS telegrams, see *parameter 9-22 Telegram Selection*.

Option:	Function:	
[0]	None	
[302]	Minimum Reference	
[303]	Maximum Reference	
[311]	Jog Speed [Hz]	
[312]	Catch up/slow Down Value	
[341]	Ramp 1 Ramp Up Time	
[342]	Ramp 1 Ramp Down Time	
[351]	Ramp 2 Ramp Up Time	
[352]	Ramp 2 Ramp Down Time	
[380]	Jog Ramp Time	
[381]	Quick Stop Ramp Time	
[412]	Motor Speed Low Limit [Hz]	
[414]	Motor Speed High Limit [Hz]	
[416]	Torque Limit Motor Mode	
[417]	Torque Limit Generator Mode	
[553]	Term. 29 High Ref./Feedb. Value	
[558]	Term. 33 High Ref./Feedb. Value	
[590]	Digital & Relay Bus Control	
[593]	Pulse Out 27 Bus Control	
[595]	Pulse Out 29 Bus Control	
[615]	Terminal 53 High Ref./Feedb. Value	
[625]	Terminal 54 High Ref./Feedb. Value	

9-15 PCD Write Configuration		
Select the parameters to be assigned to PCD 3–10 of the telegrams. The number of available PCDs depends on the telegram type. Values in PCD 3–10 are written to the selected parameters as data. For standard PROFIBUS telegrams, see <i>parameter 9-22 Telegram Selection</i> .		
Option:	Function:	
[676]	Terminal 45 Output Bus Control	
[696]	Terminal 42 Output Bus Control	
[733]	Process PID Proportional Gain	
[734]	Process PID Integral Time	
[735]	Process PID Differentiation Time	
[748]	PCD Feed Forward	
[890]	Bus Jog 1 Speed	
[891]	Bus Jog 2 Speed	
[1680]	Fieldbus CTW 1	
[1682]	Fieldbus REF 1	
[3401]	PCD 1 Write For Application	
[3402]	PCD 2 Write For Application	
[3403]	PCD 3 Write For Application	
[3404]	PCD 4 Write For Application	
[3405]	PCD 5 Write For Application	
[3406]	PCD 6 Write For Application	
[3407]	PCD 7 Write For Application	
[3408]	PCD 8 Write For Application	
[3409]	PCD 9 Write For Application	
[3410]	PCD 10 Write For Application	

9-16 PCD Read Configuration
 Select the parameters to be assigned to PCD 3–10 of the telegrams. The number of available PCDs depends on the telegram type. Values in PCD 3–10 contain the actual data values of the selected parameters.

Option:	Function:	
[0]	None	
[1500]	Operating hours	
[1501]	Running Hours	
[1502]	kWh Counter	
[1600]	Control Word	
[1601]	Reference [Unit]	
[1602]	Reference [%]	
[1603]	Status Word	
[1605]	Main Actual Value [%]	
[1609]	Custom Readout	
[1610]	Power [kW]	
[1611]	Power [hp]	
[1612]	Motor Voltage	
[1613]	Frequency	
[1614]	Motor current	
[1615]	Frequency [%]	
[1616]	Torque [Nm]	
[1617]	Speed [RPM]	
[1618]	Motor Thermal	
[1622]	Torque [%]	

9-16 PCD Read Configuration		
Select the parameters to be assigned to PCD 3–10 of the telegrams. The number of available PCDs depends on the telegram type. Values in PCD 3–10 contain the actual data values of the selected parameters.		
Option:	Function:	
[1630]	DC Link Voltage	
[1633]	Brake Energy /2 min	
[1634]	Heatsink Temp.	
[1635]	Inverter Thermal	
[1638]	SL Controller State	
[1639]	Control Card Temp.	
[1650]	External Reference	
[1652]	Feedback[Unit]	
[1653]	Digi Pot Reference	
[1657]	Feedback [RPM]	
[1660]	Digital Input	
[1661]	Terminal 53 Setting	
[1662]	Analog input 53	
[1663]	Terminal 54 Setting	
[1664]	Analog input 54	
[1665]	Analog output 42 [mA]	
[1667]	Pulse input 29 [Hz]	
[1668]	Pulse input 33 [Hz]	
[1669]	Pulse output 27 [Hz]	
[1670]	Pulse output 29 [Hz]	
[1671]	Relay output	
[1672]	Counter A	
[1673]	Counter B	
[1679]	Analog output 45 [mA]	
[1684]	Comm. Option STW	
[1685]	FC Port CTW 1	
[1690]	Alarm Word	
[1691]	Alarm Word 2	
[1692]	Warning Word	
[1693]	Warning Word 2	
[1694]	Ext. Status Word	
[1695]	Ext. Status Word 2	
[1697]	Alarm Word 3	
[3421]	PCD 1 Read For Application	
[3422]	PCD 2 Read For Application	
[3423]	PCD 3 Read For Application	
[3424]	PCD 4 Read For Application	
[3425]	PCD 5 Read For Application	
[3426]	PCD 6 Read For Application	
[3427]	PCD 7 Read For Application	
[3428]	PCD 8 Read For Application	
[3429]	PCD 9 Read For Application	
[3430]	PCD 10 Read For Application	
[3450]	Actual Position	
[3456]	Track Error	

9-18 Node Address		
Range:	Function:	
126* [1 - 126]	Enter the station address in this parameter or, alternatively, in the hardware switch. To adjust the station address in <i>parameter 9-18 Node Address</i> , set the hardware switch to 126 or 127 (that is all switches set to <i>on</i>). Otherwise, this parameter shows the actual setting of the switch.	

9-19 Drive Unit System Number		
Range:	Function:	
1037* [0 - 65535]	Manufacturer specific system ID.	

9-22 Telegram Selection		
Select a standard PROFIBUS telegram configuration for the frequency converter as an alternative to the freely configurable telegrams in <i>parameter 9-15 PCD Write Configuration</i> and <i>parameter 9-16 PCD Read Configuration</i> .		
Option:	Function:	
[1]	Standard telegram 1	
[100] *	None	
[101]	PPO 1	
[102]	PPO 2	
[103]	PPO 3	
[104]	PPO 4	
[105]	PPO 5	
[106]	PPO 6	
[107]	PPO 7	
[108]	PPO 8	
[200]	Custom telegram 1	

9-23 Parameters for Signals		
Option:	Function:	
[0] *	None	
[302]	Minimum Reference	
[303]	Maximum Reference	
[311]	Jog Speed [Hz]	
[312]	Catch up/slow Down Value	
[341]	Ramp 1 Ramp Up Time	
[342]	Ramp 1 Ramp Down Time	
[351]	Ramp 2 Ramp Up Time	
[352]	Ramp 2 Ramp Down Time	
[380]	Jog Ramp Time	
[381]	Quick Stop Ramp Time	
[412]	Motor Speed Low Limit [Hz]	
[414]	Motor Speed High Limit [Hz]	
[416]	Torque Limit Motor Mode	
[417]	Torque Limit Generator Mode	
[553]	Term. 29 High Ref./Feedb. Value	
[558]	Term. 33 High Ref./Feedb. Value	
[590]	Digital & Relay Bus Control	
[593]	Pulse Out 27 Bus Control	
[595]	Pulse Out 29 Bus Control	
[615]	Terminal 53 High Ref./Feedb. Value	

9-23 Parameters for Signals		
Option:	Function:	
[625]	Terminal 54 High Ref./Feedb. Value	
[676]	Terminal 45 Output Bus Control	
[696]	Terminal 42 Output Bus Control	
[733]	Process PID Proportional Gain	
[734]	Process PID Integral Time	
[735]	Process PID Differentiation Time	
[748]	PCD Feed Forward	
[890]	Bus Jog 1 Speed	
[891]	Bus Jog 2 Speed	
[1500]	Operating hours	
[1501]	Running Hours	
[1502]	kWh Counter	
[1600]	Control Word	
[1601]	Reference [Unit]	
[1602]	Reference [%]	
[1603]	Status Word	
[1605]	Main Actual Value [%]	
[1609]	Custom Readout	
[1610]	Power [kW]	
[1611]	Power [hp]	
[1612]	Motor Voltage	
[1613]	Frequency	
[1614]	Motor current	
[1615]	Frequency [%]	
[1616]	Torque [Nm]	
[1617]	Speed [RPM]	
[1618]	Motor Thermal	
[1622]	Torque [%]	
[1630]	DC Link Voltage	
[1633]	Brake Energy /2 min	
[1634]	Heatsink Temp.	
[1635]	Inverter Thermal	
[1638]	SL Controller State	
[1639]	Control Card Temp.	
[1650]	External Reference	
[1652]	Feedback[Unit]	
[1653]	Digi Pot Reference	
[1657]	Feedback [RPM]	
[1660]	Digital Input	
[1661]	Terminal 53 Setting	
[1662]	Analog input 53	
[1663]	Terminal 54 Setting	
[1664]	Analog input 54	
[1665]	Analog output 42 [mA]	
[1667]	Pulse input 29 [Hz]	
[1668]	Pulse input 33 [Hz]	
[1669]	Pulse output 27 [Hz]	
[1670]	Pulse output 29 [Hz]	
[1671]	Relay output	
[1672]	Counter A	
[1673]	Counter B	
[1679]	Analog output 45 [mA]	

9-23 Parameters for Signals		
Option:	Function:	
[1680]	Fieldbus CTW 1	
[1682]	Fieldbus REF 1	
[1684]	Comm. Option STW	
[1685]	FC Port CTW 1	
[1690]	Alarm Word	
[1691]	Alarm Word 2	
[1692]	Warning Word	
[1693]	Warning Word 2	
[1694]	Ext. Status Word	
[1695]	Ext. Status Word 2	
[1697]	Alarm Word 3	
[3401]	PCD 1 Write For Application	
[3402]	PCD 2 Write For Application	
[3403]	PCD 3 Write For Application	
[3404]	PCD 4 Write For Application	
[3405]	PCD 5 Write For Application	
[3406]	PCD 6 Write For Application	
[3407]	PCD 7 Write For Application	
[3408]	PCD 8 Write For Application	
[3409]	PCD 9 Write For Application	
[3410]	PCD 10 Write For Application	
[3421]	PCD 1 Read For Application	
[3422]	PCD 2 Read For Application	
[3423]	PCD 3 Read For Application	
[3424]	PCD 4 Read For Application	
[3425]	PCD 5 Read For Application	
[3426]	PCD 6 Read For Application	
[3427]	PCD 7 Read For Application	
[3428]	PCD 8 Read For Application	
[3429]	PCD 9 Read For Application	
[3430]	PCD 10 Read For Application	
[3450]	Actual Position	
[3456]	Track Error	

9-27 Parameter Edit		
Option:	Function:	
		Parameters can be edited via PROFIBUS, the standard RS485 interface, or the LCP.
[0]	Disabled	Disable editing via PROFIBUS.
[1] *	Enabled	Enable editing via PROFIBUS.

9-28 Process Control		
Option:	Function:	
		Process control (setting of control word, speed reference, and process data) is possible via either PROFIBUS or standard fieldbus, but not both simultaneously. Local control is always possible via the LCP. Control via process control is possible via either terminals or fieldbus depending on the settings in <i>parameter 8-50 Coasting Select</i> to <i>parameter 8-56 Preset Reference Select</i> .
[0]	Disable	Disables process control via PROFIBUS master class 1 and enables process control via standard fieldbus or PROFIBUS master class 2.
[1]	Enable cyclic master	Enables process control via PROFIBUS master class 1 and disables process control via standard fieldbus or PROFIBUS master class 2.

9-44 Fault Message Counter		
Range:	Function:	
0* [0 - 65535]	Indicates the number of fault events presently stored in <i>parameter 9-45 Fault Code</i> . The buffer capacity is maximum 8 error events. The buffer and counter are set to 0 by reset or power-up.	

9-45 Fault Code		
Range:	Function:	
0* [0 - 0]	This buffer contains the alarm word for all alarms and warnings that have occurred since last reset or power-up. The buffer capacity is maximum 8 error events.	

9-47 Fault Number		
Range:	Function:	
0* [0 - 0]	This buffer contains the alarm word for all alarms and warnings that have occurred since last reset or power-up. The buffer capacity is maximum 8 error events.	

9-52 Fault Situation Counter		
Range:	Function:	
0* [0 - 1000]	Indicates the number of fault events that have occurred since last reset or power-up.	

9-53 Profibus Warning Word		
Range:	Function:	
0* [0 - 65535]	This parameter shows PROFIBUS communication warnings.	
	Bit	Description
	0	Connection with DP master is lost.
	1	Not used.
	2	FDL (fieldbus data link layer) is not OK.
	3	Clear data command received.
	4	Actual value is not updated.
	5	Baud rate search.
	6	PROFIBUS ASIC is not transmitting.
	7	Initializing of PROFIBUS is not OK.
	8	Frequency converter is tripped.
	9	Internal CAN error.
	10	Wrong configuration data from PLC.
	11	Wrong ID sent by PLC.
	12	Internal fault occurred.
	13	Not configured.
	14	Timeout active.
	15	Warning 34 active.
Table 4.8 Bit Definition		

9-63 Actual Baud Rate		
Option:	Function:	
		This parameter shows the actual PROFIBUS baud rate. The PROFIBUS master automatically sets the baud rate.
[0]	9,6 kbit/s	
[1]	19,2 kbit/s	
[2]	93,75 kbit/s	
[3]	187,5 kbit/s	
[4]	500 kbit/s	
[6]	1500 kbit/s	
[7]	3000 kbit/s	
[8]	6000 kbit/s	
[9]	12000 kbit/s	
[10]	31,25 kbit/s	
[11]	45,45 kbit/s	
[255] *	No baudrate found	

9-64 Device Identification																																		
Range:	Function:																																	
0* [0 - 0]	<p>NOTICE This parameter is not visible via LCP.</p> <p>The device identification parameter. The data type is array [n] of unsigned16. The assignment of the 1st subindexes is defined and shown in <i>Table 4.9</i>.</p> <table border="1"> <thead> <tr> <th>Index</th> <th>Content</th> <th>Value</th> </tr> </thead> <tbody> <tr> <td>0</td> <td>Manufacturer</td> <td>128</td> </tr> <tr> <td>1</td> <td>Device type</td> <td>1</td> </tr> <tr> <td>2</td> <td>Version</td> <td>xxyy</td> </tr> <tr> <td>3</td> <td>Firmware date year</td> <td>yyyy</td> </tr> <tr> <td>4</td> <td>Firmware date month</td> <td>ddmm</td> </tr> <tr> <td>5</td> <td>No. of axes</td> <td>Variable</td> </tr> <tr> <td>6</td> <td>Vendor specific: PB Version</td> <td>xxyy</td> </tr> <tr> <td>7</td> <td>Vendor specific: Database Version</td> <td>xxyy</td> </tr> <tr> <td>8</td> <td>Vendor specific: AOC Version</td> <td>xxyy</td> </tr> <tr> <td>9</td> <td>Vendor specific: MOC Version</td> <td>xxyy</td> </tr> </tbody> </table> <p>Table 4.9 Device Identification 1st Subindex Assignment</p>	Index	Content	Value	0	Manufacturer	128	1	Device type	1	2	Version	xxyy	3	Firmware date year	yyyy	4	Firmware date month	ddmm	5	No. of axes	Variable	6	Vendor specific: PB Version	xxyy	7	Vendor specific: Database Version	xxyy	8	Vendor specific: AOC Version	xxyy	9	Vendor specific: MOC Version	xxyy
Index	Content	Value																																
0	Manufacturer	128																																
1	Device type	1																																
2	Version	xxyy																																
3	Firmware date year	yyyy																																
4	Firmware date month	ddmm																																
5	No. of axes	Variable																																
6	Vendor specific: PB Version	xxyy																																
7	Vendor specific: Database Version	xxyy																																
8	Vendor specific: AOC Version	xxyy																																
9	Vendor specific: MOC Version	xxyy																																

9-65 Profile Number	
Range:	Function:
0* [0 - 0]	<p>NOTICE This parameter is not visible via LCP.</p> <p>This parameter contains the profile identification. Byte 1 contains the profile number and byte 2 the version number of the profile.</p>

9-67 Control Word 1	
Range:	Function:
0* [0 - 65535]	This parameter accepts the control word from a master class 2 in the same format as PCD 1.

9-68 Status Word 1	
Range:	Function:
0* [0 - 65535]	This parameter delivers the status word for a master class 2 in the same format as PCD 2.

9-70 Edit Set-up	
Option:	Function:
	Select the set-up in which programming (change of data) is performed during operation. It is possible to program the 2 set-ups independently of the set-up selected as active set-up. Parameter access from each master is directed to the set-up selected by the individual master (cyclic, acyclic MCL1, 1 st acyclic MCL2, 2 nd acyclic MCL2, 3 rd acyclic MCL2).
[1]	Set-up 1
[2]	Set-up 2
[9] *	Active Set-up

9-71 Profibus Save Data Values	
Option:	Function:
	Parameter values changed via RS485 are not automatically stored in a non-volatile memory. Use this parameter to activate a function that stores parameter values in the EEPROM non-volatile memory, so changed parameter values are retained at power-down.
[0] *	Off Deactivates the non-volatile storage function.
[1]	Store all setups Stores all parameter values in the set-up selected in <i>parameter 9-70 Edit Set-up</i> in the non-volatile memory. The selection returns to [0] Off when all values are stored.

9-72 ProfibusDriveReset	
Option:	Function:
	NOTICE Resets the VLT® PROFIBUS DP MCA 101 option only.
[0] *	No action
[1]	Power-on reset Resets the frequency converter after power-up, as for power cycle.
[2]	Power-on reset prep
[3]	Comm option reset When reset, the frequency converter disappears from the fieldbus, which may cause a communication error from the master.

9-75 DO Identification	
Range:	Function:
0* [0 - 65535]	Provides information about the DO (drive object). This parameter is for PROFINET only.

9-80 Defined Parameters (1)		
Range:	Function:	
0* [0 - 9999]	This parameter shows a list of all the defined frequency converter parameters.	

9-81 Defined Parameters (2)		
Range:	Function:	
0* [0 - 9999]	This parameter shows a list of all the defined frequency converter parameters.	

9-82 Defined Parameters (3)		
Range:	Function:	
0* [0 - 9999]	This parameter shows a list of all the defined frequency converter parameters.	

9-83 Defined Parameters (4)		
Range:	Function:	
0* [0 - 9999]	This parameter shows a list of all the defined frequency converter parameters.	

9-84 Defined Parameters (5)		
Range:	Function:	
0* [0 - 9999]	This parameter shows a list of all the defined frequency converter parameters.	

9-85 Defined Parameters (6)		
Range:	Function:	
0* [0 - 9999]	This parameter shows a list of all the defined frequency converter parameters.	

9-90 Changed Parameters (1)		
Range:	Function:	
0* [0 - 9999]	This parameter shows a list of all the frequency converter parameters deviating from default setting.	

9-91 Changed Parameters (2)		
Range:	Function:	
0* [0 - 9999]	This parameter shows a list of all the frequency converter parameters deviating from default setting.	

9-92 Changed Parameters (3)		
Range:	Function:	
0* [0 - 9999]	This parameter shows a list of all the frequency converter parameters deviating from default setting.	

9-93 Changed Parameters (4)		
Range:	Function:	
0* [0 - 9999]	This parameter shows a list of all the frequency converter parameters deviating from default setting.	

9-94 Changed Parameters (5)		
Range:	Function:	
0* [0 - 9999]	This parameter shows a list of all the frequency converter parameters deviating from default setting.	

9-99 Profibus Revision Counter		
Range:	Function:	
0* [0 - 65535]	Readout of revision count.	

4.11 Parameters: 12-** Ethernet

For more information about Ethernet parameter descriptions, see the *VLT® AutomationDrive FC 360 PROFINET Programming Guide*.

4.11.1 12-0* IP Settings

12-00 IP Address Assignment		
Option:	Function:	
		Select the IP address assignment method.
[0]	MANUAL	IP address can be set in <i>parameter 12-01 IP Address</i> IP Address.
[1]	DHCP	IP address is assigned via DHCP server.
[2]	BOOTP	IP address is assigned via BOOTP server.
[10] *	DCP	DCP is assigned via the DCP protocol.

12-01 IP Address		
Range:	Function:	
0* [0 - 4294967295]	Configure the IP address of the option. Read-only if <i>parameter 12-00 IP Address Assignment</i> is set to [1] DHCP, [2] BOOTP, or via DIP switches.	

12-02 Subnet Mask		
Range:	Function:	
0* [0 - 4294967295]	Configure the IP subnet mask of the option. Read-only if <i>parameter 12-00 IP Address Assignment</i> is set to [1] DHCP or [2] BOOTP.	

12-03 Default Gateway		
Range:	Function:	
0* [0 - 4294967295]	Configure the IP default gateway of the option. Read-only if <i>parameter 12-00 IP Address Assignment</i> set to [1] DHCP or [2] BOOTP.	

12-04 DHCP Server		
Range:	Function:	
0* [0 - 2147483647]	<p>NOTICE</p> <p>A power cycle is necessary after setting the IP parameters manually.</p> <p>Read only. Shows the IP address of the found DHCP or BOOTP server.</p>	

12-05 Lease Expires		
Range:	Function:	
0* [0 - 4294967295]	Read only. Shows the lease time left for the current DHCP-assigned IP address.	

12-06 Name Servers		
Range:	Function:	
0* [0 - 4294967295]	IP addresses of domain name servers. Can be automatically assigned when using DHCP.	

12-07 Domain Name		
Range:	Function:	
0* [1 - 48]	Domain name of the attached network. Can be automatically assigned when using DHCP network.	

12-08 Host Name		
Range:	Function:	
0* [1 - 48]	Logical (given) name of option.	

12-09 Physical Address		
Range:	Function:	
0* [0 - 17]	Read only. Shows the physical (MAC) address of the option.	

4.11.2 12-1* Ethernet Link Parameters

12-10 Link Status		
Option:	Function:	
[0] *	No Link	
[1]	Link	Shows the link status of the Ethernet ports.

12-11 Link Duration		
Range:	Function:	
Size related* [0 - 0]	Shows the duration of the present link on each port in dd:hh:mm:ss.	

12-12 Auto Negotiation		
Option:	Function:	
	Off	Configures auto negotiation of Ethernet link parameters, for each port: ON or OFF.
[0]	Off	Link speed and link duplex can be configured in <i>parameter 12-13 Link Speed</i> and <i>parameter 12-14 Link Duplex</i> .
[1] *	On	

12-13 Link Speed		
Option:	Function:	
		Forces the link speed for each port in 10 Mbps or 100 Mbps. If <i>parameter 12-12 Auto Negotiation</i> is set to [1] On, this parameter is read-only and shows the actual link speed. If no link is present, None is shown.
[0] *	None	
[1]	10 Mbps	
[2]	100 Mbps	

12-14 Link Duplex		
Option:	Function:	
		Forces the duplex for each port to full or half duplex. If <i>parameter 12-12 Auto Negotiation</i> is set to [1] On, this parameter is read-only.
[0]	Half Duplex	
[1] *	Full Duplex	

4.11.3 12-8* Other Ethernet Services

12-80 FTP Server		
Option:	Function:	
[0] *	Disabled	
[1]	Enabled	

12-81 HTTP Server		
Option:	Function:	
[0] *	Disabled	
[1]	Enabled	

12-82 SMTP Service		
Option:	Function:	
[0] *	Disabled	
[1]	Enabled	

12-89 Transparent Socket Channel Port		
Range:	Function:	
4000*	[0 - 65535]	Configures the TCP port number for the transient socket channel. This enables FC telegrams to be sent transiently on Ethernet via TCP. Default value is 4000. 0 indicates disabled.

4.11.4 12-9* Advanced Ethernet Services

12-90 Cable Diagnostic		
Option:	Function:	
		Enables/disables advanced cable diagnosis function. If enabled, the distance to cable errors can be read out in <i>parameter 12-93 Cable Error Length</i> . The parameter resumes to the default setting [0] Disable after the diagnostics have finished.
		NOTICE The cable diagnostics function is only issued on ports where there is no link (see <i>parameter 12-10 Link Status</i>).
[0] *	Disabled	
[1]	Enabled	

12-91 Auto Cross Over		
Option:	Function:	
		NOTICE Disabling of the auto-crossover function requires crossed Ethernet cables for daisy-chaining the options.
[0]	Disabled	Disables the auto-crossover function.
[1] *	Enabled	Enables the auto-crossover function.

12-92 IGMP Snooping		
Option:	Function:	
[0]	Disabled	
[1] *	Enabled	

12-93 Cable Error Length		
Range:	Function:	
0*	[0 - 65535]	If cable diagnostics is enabled in <i>parameter 12-90 Cable Diagnostic</i> , the built-in switch is possible via time domain reflectometry (TDR). This is a measurement technique which detects common cabling problems such as open circuits, short circuits, and impedance mismatches or breaks in transmission cables. The distance from the option to the error is shown in meters with an accuracy of ±2 m (6.6 ft). The value 0 means no errors detected.

12-94 Broadcast Storm Protection		
Range:	Function:	
-1 % *	[-1 - 20 %]	The built-in switch is capable of protecting the switch system from receiving too many broadcast packages, which can use up network resources. The value indicates a percentage of the total bandwidth that is allowed for broadcast messages. Example: OFF means that the filter is disabled - all broadcast messages are passed through. The value 0% means that no broadcast messages are passed through. A value of 10% means that 10% of the total bandwidth is allowed for broadcast messages. If the amount of broadcast messages exceeds the 10% threshold, they are blocked.

12-95 Broadcast Storm Filter		
Applies to <i>parameter 12-94 Broadcast Storm Protection</i> , if the broadcast storm protection also includes multicast telegrams.		
Option:	Function:	
[0] *	Broadcast only	
[1]	Broadcast & Multicast	

12-96 Port Config

Option:		Function:
[0] *	Normal	
[1]	Mirror Port 1 to 2	
[2]	Mirror Port 2 to 1	
[10]	Port 1 disabled	
[11]	Port 2 disabled	
[254]	Mirror Int. Port to 1	
[255]	Mirror Int. Port to 2	

12-98 Interface Counters

Range:		Function:
4000*	[0 - 4294967295]	Read-only. Advanced interface counters from a built-in switch can be used for low-level trouble shooting. The parameter shows a sum of port 1 + port 2.

12-99 Media Counters

Range:		Function:
0*	[0 - 4294967295]	Read-only. Advanced interface counters from a built-in switch can be used for low-level troubleshooting. The parameter shows a sum of port 1 + port 2.

4.12 Parameters: 13-*** Smart Logic Control

Smart logic control (SLC) is a sequence of user-defined actions (see *parameter 13-52 SL Controller Action*) executed by the SLC when the associated user-defined event (see *parameter 13-51 SL Controller Event*) is evaluated as true by the SLC.

The condition for an event can be a particular status, or that the output from a logic rule or a comparator operand becomes true. That leads to an associated action as illustrated:

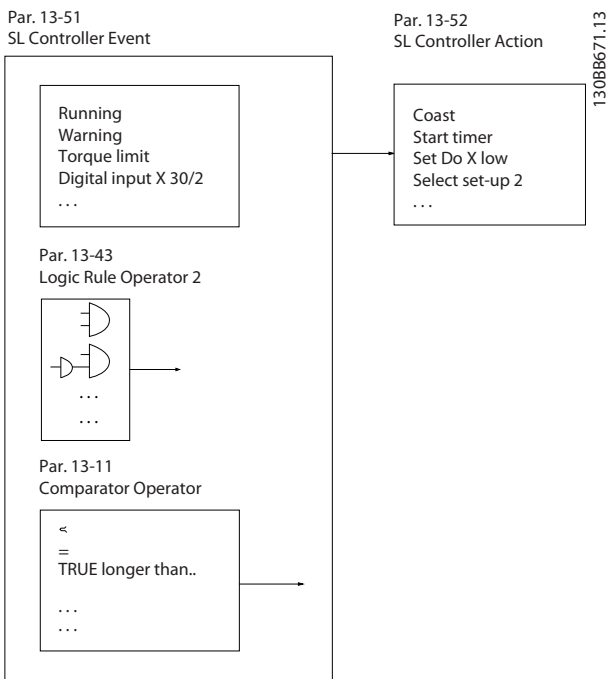

Illustration 4.25 Smart Logic Control (SLC)

Events and actions are each numbered and linked in pairs (states). This means that when the first event is fulfilled (becomes true), the first action is executed. After this, the conditions of the 2nd event are evaluated and if evaluated true, the 2nd action is executed, and so on. Only 1 event is evaluated at any time. If an event is evaluated as false, nothing happens (in the SLC) during the current scan interval and no other events are evaluated. This means that when the SLC starts, it evaluates the first event (and only the first event) in each scan interval. Only when the first event is evaluated true, the SLC executes the first action and starts evaluating the 2nd event. It is possible to program 1–20 events and actions.

When the last event/action has been executed, the sequence starts over again from the first event/action.

Illustration 4.26 shows an example with 3 events/actions:

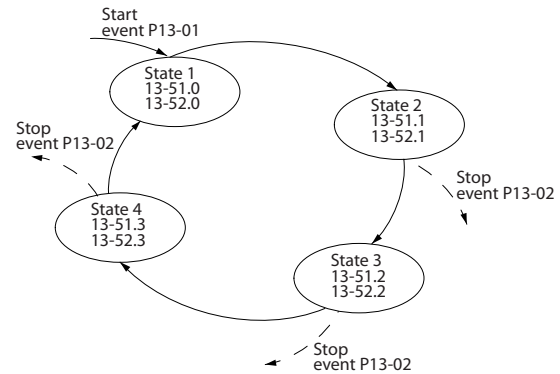

Illustration 4.26 Events and Actions

Starting and stopping the SLC

Start and stop the SLC by selecting [1] On or [0] Off in *parameter 13-00 SL Controller Mode*. The SLC always starts in state 0 (where it evaluates event [0]). The SLC starts when the *Start Event* (defined in *parameter 13-01 Start Event*) is evaluated as true (provided that [1] On is selected in *parameter 13-00 SL Controller Mode*). The SLC stops when the *stop event* (*parameter 13-02 Stop Event*) is true. *Parameter 13-03 Reset SLC* resets all SLC parameters and starts programming from scratch.

NOTICE

SLC is only active in auto-on mode, not hand-on mode.

4.12.1 13-0* SLC Settings

Use the SLC settings to activate, deactivate, and reset the smart logic control sequence. The logic functions and comparators are always running in the background, which opens for separate control of digital inputs and outputs.

13-00 SL Controller Mode		
Option:	Function:	
[0] *	Off	Disable the smart logic controller.
[1]	On	Enable the smart logic controller.

13-01 Start Event		
Option:	Function:	
[0]	False	
[1]	True	
[2]	Running	
[3]	In range	
[4]	On reference	
[7]	Out of current range	
[8]	Below I low	
[9]	Above I high	
[16]	Thermal warning	
[17]	Mains out of range	
[18]	Reversing	
[19]	Warning	
[20]	Alarm (trip)	
[21]	Alarm (trip lock)	
[22]	Comparator 0	
[23]	Comparator 1	
[24]	Comparator 2	
[25]	Comparator 3	
[26]	Logic rule 0	
[27]	Logic rule 1	
[28]	Logic rule 2	
[29]	Logic rule 3	
[33]	Digital input DI18	
[34]	Digital input DI19	
[35]	Digital input DI27	
[36]	Digital input DI29	
[39] *	Start command	
[40]	Drive stopped	
[42]	Auto Reset Trip	
[50]	Comparator 4	
[51]	Comparator 5	
[60]	Logic rule 4	
[61]	Logic rule 5	
[83]	Broken Belt	

13-02 Stop Event		
Option:	Function:	
[0]	False	
[1]	True	
[2]	Running	
[3]	In range	
[4]	On reference	
[7]	Out of current range	
[8]	Below I low	
[9]	Above I high	
[16]	Thermal warning	
[17]	Mains out of range	
[18]	Reversing	
[19]	Warning	
[20]	Alarm (trip)	
[21]	Alarm (trip lock)	
[22]	Comparator 0	
[23]	Comparator 1	
[24]	Comparator 2	
[25]	Comparator 3	
[26]	Logic rule 0	
[27]	Logic rule 1	
[28]	Logic rule 2	
[29]	Logic rule 3	
[30]	SL Time-out 0	
[31]	SL Time-out 1	
[32]	SL Time-out 2	
[33]	Digital input DI18	
[34]	Digital input DI19	
[35]	Digital input DI27	
[36]	Digital input DI29	
[39]	Start command	
[40] *	Drive stopped	
[42]	Auto Reset Trip	
[50]	Comparator 4	
[51]	Comparator 5	
[60]	Logic rule 4	
[61]	Logic rule 5	
[70]	SL Time-out 3	
[71]	SL Time-out 4	
[72]	SL Time-out 5	
[73]	SL Time-out 6	
[74]	SL Time-out 7	
[83]	Broken Belt	

13-03 Reset SLC		
Option:	Function:	
[0] *	Do not reset SLC	Retain programmed settings in <i>parameter group 13-** Smart Logic</i> .
[1]	Reset SLC	Reset all parameters in <i>parameter group 13-** Smart Logic</i> to default settings.

4.12.2 13-1* Comparators

Comparators are used for comparing continuous variables (that is output frequency, output current, analog input, and so on.) to fixed preset values.

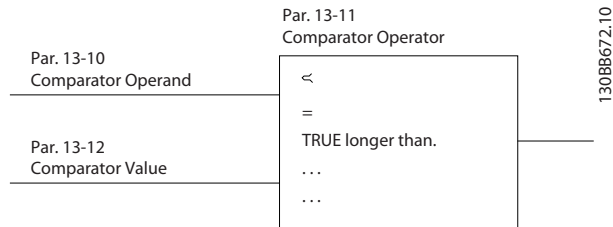

Illustration 4.27 Comparators

There are digital values that are compared to fixed time values. See explanation in *parameter 13-10 Comparator Operand*. Comparators are evaluated once in each scan interval. Use the result (true or false) directly. All parameters in this parameter group are array parameters with index 0 to 5. Select index 0 to program comparator 0, select index 1 to program comparator 1, and so on.

13-10 Comparator Operand		
Option:	Function:	
[0] *	Disabled	
[1]	Reference %	
[2]	Feedback %	
[3]	Motor speed	
[4]	Motor Current	
[6]	Motor power	
[7]	Motor voltage	
[8]	DC-link voltage	
[12]	Analog input AI53	
[13]	Analog input AI54	
[18]	Pulse input FI29	
[19]	Pulse input FI33	
[20]	Alarm number	
[30]	Counter A	
[31]	Counter B	

13-11 Comparator Operator		
Option:	Function:	
		Select the operator to be used in the comparison. This is an array parameter containing comparator operators 0–5.
[0]	Less Than (<)	The result of the evaluation is true when the variable selected in <i>parameter 13-10 Comparator Operand</i> is smaller than the fixed value in <i>parameter 13-12 Comparator Value</i> . The result is false if the variable selected in <i>parameter 13-10 Comparator Operand</i> is greater than the fixed value in <i>parameter 13-12 Comparator Value</i> .
[1] *	Approx.Equal (~)	The result of the evaluation is true when the variable speed selected in <i>parameter 13-10 Comparator Operand</i> is approximately equal to the fixed value in <i>parameter 13-12 Comparator Value</i> .
[2]	Greater Than (>)	Inverse logic of [0] Less Than (<).

13-12 Comparator Value		
Range:	Function:	
0* [-9999 - 9999]	Enter the trigger level for the variable that is monitored by this comparator. This is an array parameter containing comparator values 0–5.	

4.12.3 13-2* Timers

Use the result (true or false) from timers directly to define an event (see *parameter 13-51 SL Controller Event*), or as boolean input in a logic rule (see *parameter 13-40 Logic Rule Boolean 1*, *parameter 13-42 Logic Rule Boolean 2*, or *parameter 13-44 Logic Rule Boolean 3*). A timer is only false when started by an action (for example [29] Start timer 1) until the timer value entered in this parameter has elapsed. Then it becomes true again.

All parameters in this parameter group are array parameters with index 0 to 2. Select index 0 to program timer 0, select index 1 to program timer 1, and so on.

13-20 SL Controller Timer		
Range:	Function:	
0 s* [0 - 3600 s]	Enter the value to define the duration of the false output from the programmed timer. A timer is only false if it is started by an action (for example [29] Start timer 1) and until the given timer value has elapsed.	

4.12.4 13-4* Logic Rules

Combine up to 3 boolean inputs (true/false inputs) from timers, comparators, digital inputs, status bits, and events using the logical operators AND, OR, and NOT. Select boolean inputs for the calculation in *parameter 13-40 Logic Rule Boolean 1*, *parameter 13-42 Logic Rule Boolean 2*, and *parameter 13-44 Logic Rule Boolean 3*. Define the operators used to logically combine the selected inputs in *parameter 13-41 Logic Rule Operator 1* and *parameter 13-43 Logic Rule Operator 2*.

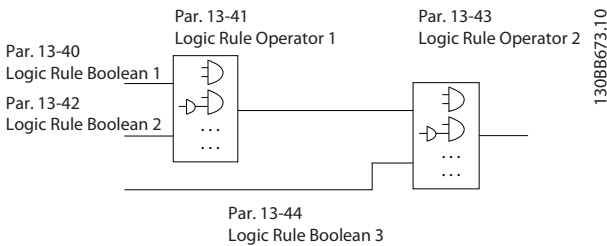

Illustration 4.28 Logic Rules

Priority of calculation

The results of *parameter 13-40 Logic Rule Boolean 1*, *parameter 13-41 Logic Rule Operator 1*, and *parameter 13-42 Logic Rule Boolean 2* are calculated first. The outcome (true/false) of this calculation is combined with the settings of *parameter 13-43 Logic Rule Operator 2* and *parameter 13-44 Logic Rule Boolean 3*, yielding the final result (true/false) of the logic rule.

13-40 Logic Rule Boolean 1	
Option:	Function:
	Select the 1 st boolean (true or false) input for the selected logic rule. See <i>parameter 13-01 Start Event ([0]–[61])</i> and <i>parameter 13-02 Stop Event ([70]–[74])</i> for further description.
[0] *	False
[1]	True
[2]	Running
[3]	In range
[4]	On reference
[7]	Out of current range
[8]	Below I low
[9]	Above I high
[16]	Thermal warning
[17]	Mains out of range
[18]	Reversing
[19]	Warning
[20]	Alarm (trip)
[21]	Alarm (trip lock)
[22]	Comparator 0
[23]	Comparator 1
[24]	Comparator 2

13-40 Logic Rule Boolean 1	
Option:	Function:
[25]	Comparator 3
[26]	Logic rule 0
[27]	Logic rule 1
[28]	Logic rule 2
[29]	Logic rule 3
[30]	SL Time-out 0
[31]	SL Time-out 1
[32]	SL Time-out 2
[33]	Digital input DI18
[34]	Digital input DI19
[35]	Digital input DI27
[36]	Digital input DI29
[39]	Start command
[40]	Drive stopped
[42]	Auto Reset Trip
[50]	Comparator 4
[51]	Comparator 5
[60]	Logic rule 4
[61]	Logic rule 5
[70]	SL Time-out 3
[71]	SL Time-out 4
[72]	SL Time-out 5
[73]	SL Time-out 6
[74]	SL Time-out 7
[83]	Broken Belt

13-41 Logic Rule Operator 1	
Option:	Function:
	Select the 1 st logical operator to use on the boolean inputs from <i>parameter 13-40 Logic Rule Boolean 1</i> and <i>parameter 13-42 Logic Rule Boolean 2</i> .
[0] *	Disabled Ignore <i>parameter 13-42 Logic Rule Boolean 2</i> , <i>parameter 13-43 Logic Rule Operator 2</i> , and <i>parameter 13-44 Logic Rule Boolean 3</i> .
[1]	AND Evaluate the expression [13-40] AND [13-42].
[2]	OR Evaluate the expression [13-40] OR [13-42].
[3]	AND NOT Evaluate the expression [13-40] AND NOT [13-42].
[4]	OR NOT Evaluate the expression [13-40] OR NOT [13-42].
[5]	NOT AND Evaluate the expression NOT [13-40] AND [13-42].
[6]	NOT OR Evaluate the expression NOT [13-40] OR [13-42].
[7]	NOT AND NOT Evaluate the expression NOT [13-40] AND NOT [13-42].
[8]	NOT OR NOT Evaluate the expression NOT [13-40] OR NOT [13-42].

13-42 Logic Rule Boolean 2		
Option:	Function:	
		Select the 2 nd boolean (true or false) input for the selected logic rule. See <i>parameter 13-01 Start Event ([0]–[61])</i> , and <i>parameter 13-02 Stop Event ([70]–[74])</i> for further description.
[0] *	False	
[1]	True	
[2]	Running	
[3]	In range	
[4]	On reference	
[7]	Out of current range	
[8]	Below I low	
[9]	Above I high	
[16]	Thermal warning	
[17]	Mains out of range	
[18]	Reversing	
[19]	Warning	
[20]	Alarm (trip)	
[21]	Alarm (trip lock)	
[22]	Comparator 0	
[23]	Comparator 1	
[24]	Comparator 2	
[25]	Comparator 3	
[26]	Logic rule 0	
[27]	Logic rule 1	
[28]	Logic rule 2	
[29]	Logic rule 3	
[30]	SL Time-out 0	
[31]	SL Time-out 1	
[32]	SL Time-out 2	
[33]	Digital input DI18	
[34]	Digital input DI19	
[35]	Digital input DI27	
[36]	Digital input DI29	
[39]	Start command	
[40]	Drive stopped	
[42]	Auto Reset Trip	
[50]	Comparator 4	
[51]	Comparator 5	
[60]	Logic rule 4	
[61]	Logic rule 5	
[70]	SL Time-out 3	
[71]	SL Time-out 4	
[72]	SL Time-out 5	
[73]	SL Time-out 6	
[74]	SL Time-out 7	
[83]	Broken Belt	

13-43 Logic Rule Operator 2		
Option:	Function:	
		Select the 2 nd logical operator to be used on the boolean input calculated in <i>parameter 13-40 Logic Rule Boolean 1</i> , <i>parameter 13-41 Logic Rule Operator 1</i> , and <i>parameter 13-42 Logic Rule Boolean 2</i> , and the boolean input coming from <i>parameter 13-40 Logic Rule Boolean 2</i> . <i>Parameter 13-42 Logic Rule Boolean 2</i> signifies the boolean input of <i>parameter 13-44 Logic Rule Boolean 3</i> . <i>Parameter 13-40 Logic Rule Boolean 1</i> , and <i>parameter 13-42 Logic Rule Boolean 2</i> signify the boolean input calculated in <i>parameter 13-40 Logic Rule Boolean 1</i> , <i>parameter 13-41 Logic Rule Operator 1</i> , and <i>parameter 13-42 Logic Rule Boolean 2</i> .
[0] *	Disabled	Ignore <i>parameter 13-44 Logic Rule Boolean 3</i> .
[1]	AND	
[2]	OR	
[3]	AND NOT	
[4]	OR NOT	
[5]	NOT AND	
[6]	NOT OR	
[7]	NOT AND NOT	
[8]	NOT OR NOT	

13-44 Logic Rule Boolean 3		
Option:	Function:	
		Select the 3 rd boolean (true or false) input for the selected logic rule. See <i>parameter 13-40 Logic Rule Boolean 1</i> , <i>parameter 13-41 Logic Rule Operator 1</i> , and <i>parameter 13-42 Logic Rule Boolean 2</i> , and the boolean input. See <i>parameter 13-01 Start Event ([0]–[61])</i> , and <i>parameter 13-02 Stop Event ([70]–[74])</i> for further description.
[0] *	False	
[1]	True	
[2]	Running	
[3]	In range	
[4]	On reference	
[7]	Out of current range	
[8]	Below I low	
[9]	Above I high	
[16]	Thermal warning	
[17]	Mains out of range	
[18]	Reversing	
[19]	Warning	
[20]	Alarm (trip)	
[21]	Alarm (trip lock)	

13-44 Logic Rule Boolean 3		
Option:	Function:	
[22]	Comparator 0	
[23]	Comparator 1	
[24]	Comparator 2	
[25]	Comparator 3	
[26]	Logic rule 0	
[27]	Logic rule 1	
[28]	Logic rule 2	
[29]	Logic rule 3	
[30]	SL Time-out 0	
[31]	SL Time-out 1	
[32]	SL Time-out 2	
[33]	Digital input DI18	
[34]	Digital input DI19	
[35]	Digital input DI27	
[36]	Digital input DI29	
[39]	Start command	
[40]	Drive stopped	
[42]	Auto Reset Trip	
[50]	Comparator 4	
[51]	Comparator 5	
[60]	Logic rule 4	
[61]	Logic rule 5	
[70]	SL Time-out 3	
[71]	SL Time-out 4	
[72]	SL Time-out 5	
[73]	SL Time-out 6	
[74]	SL Time-out 7	
[83]	Broken Belt	

13-51 SL Controller Event		
Option:	Function:	
[18]	Reversing	
[19]	Warning	
[20]	Alarm (trip)	
[21]	Alarm (trip lock)	
[22]	Comparator 0	
[23]	Comparator 1	
[24]	Comparator 2	
[25]	Comparator 3	
[26]	Logic rule 0	
[27]	Logic rule 1	
[28]	Logic rule 2	
[29]	Logic rule 3	
[30]	SL Time-out 0	
[31]	SL Time-out 1	
[32]	SL Time-out 2	
[33]	Digital input DI18	
[34]	Digital input DI19	
[35]	Digital input DI27	
[36]	Digital input DI29	
[39]	Start command	
[40]	Drive stopped	
[42]	Auto Reset Trip	
[50]	Comparator 4	
[51]	Comparator 5	
[60]	Logic rule 4	
[61]	Logic rule 5	
[70]	SL Time-out 3	
[71]	SL Time-out 4	
[72]	SL Time-out 5	
[73]	SL Time-out 6	
[74]	SL Time-out 7	
[83]	Broken Belt	

4.12.5 13-5* States

13-51 SL Controller Event		
Option:	Function:	
		Select the 3 rd boolean (true or false) input for the selected logic rule. See <i>parameter 13-40 Logic Rule Boolean 1</i> , <i>parameter 13-41 Logic Rule Operator 1</i> , <i>parameter 13-42 Logic Rule Boolean 2</i> , and the boolean input. See <i>parameter 13-01 Start Event ([0]–[61])</i> and <i>parameter 13-02 Stop Event ([70]–[74])</i> for further description.
[0] *	False	
[1]	True	
[2]	Running	
[3]	In range	
[4]	On reference	
[7]	Out of current range	
[8]	Below I low	
[9]	Above I high	
[16]	Thermal warning	
[17]	Mains out of range	

13-52 SL Controller Action		
Option:	Function:	
[0] *	Disabled	Select the action corresponding to the SLC event. Actions are executed when the corresponding event (defined in <i>parameter 13-51 SL Controller Event</i>) is evaluated as true.
[1]	No action	
[2]	Select set-up 1	Changes the active set-up (<i>parameter 0-10 Active Set-up</i>) to 1. If the set-up is changed, it merges with other set-up commands coming from either the digital inputs, or via a fieldbus.
[3]	Select set-up 2	Changes the active set-up (<i>parameter 0-10 Active Set-up</i>) to 2. If the set-up is changed, it merges with other set-up commands coming from either the digital inputs, or via a fieldbus.

13-52 SL Controller Action		
Option:	Function:	
[10]	Select preset ref 0	Select preset reference 0. If the active preset reference is changed, it merges with other preset reference commands coming from either the digital inputs or via a fieldbus.
[11]	Select preset ref 1	Selects preset reference 1. If the active preset reference is changed, it merges with other preset reference commands coming from either the digital inputs, or via a fieldbus.
[12]	Select preset ref 2	Selects preset reference 2. If the active preset reference is changed, it merges with other preset reference commands coming from either the digital inputs, or via a fieldbus.
[13]	Select preset ref 3	Selects preset reference 3. If the active preset reference is changed, it merges with other preset reference commands coming from either the digital inputs, or via a fieldbus.
[14]	Select preset ref 4	Selects preset reference 4. If the active preset reference is changed, it merges with other preset reference commands coming from either the digital inputs, or via a fieldbus.
[15]	Select preset ref 5	Selects preset reference 5. If the active preset reference is changed, it merges with other preset reference commands coming from either the digital inputs, or via a fieldbus.
[16]	Select preset ref 6	Selects preset reference 6. If the active preset reference is changed, it merges with other preset reference commands coming from either the digital inputs, or via a fieldbus.
[17]	Select preset ref 7	Selects preset reference 7. If the active preset reference is changed, it merges with other preset reference commands coming from either the digital inputs, or via a fieldbus.
[18]	Select ramp 1	Selects ramp 1.
[19]	Select ramp 2	Selects ramp 2.
[22]	Run	Issues a start command to the frequency converter.
[23]	Run reverse	Issues a start reverse command to the frequency converter.
[24]	Stop	Issues a stop command to the frequency converter.
[25]	Qstop	Issues a quick stop command to the frequency converter.

13-52 SL Controller Action		
Option:	Function:	
[26]	DC Brake	Issues a DC-brake command to the frequency converter.
[27]	Coast	The frequency converter coasts immediately. All stop commands including the coast command stop the SLC.
[28]	Freeze output	Freezes the output of the frequency converter.
[29]	Start timer 0	See <i>parameter 13-20 SL Controller Timer</i> for further description.
[30]	Start timer 1	See <i>parameter 13-20 SL Controller Timer</i> for further description.
[31]	Start timer 2	See <i>parameter 13-20 SL Controller Timer</i> for further description.
[32]	Set digital out A low	Any output with SL output A is low.
[33]	Set digital out B low	Any output with SL output B is low.
[34]	Set digital out C low	Any output with SL output C is low.
[35]	Set digital out D low	Any output with SL output D is low.
[38]	Set digital out A high	Any output with SL output A is high.
[39]	Set digital out B high	Any output with SL output B is high.
[40]	Set digital out C high	Any output with SL output C is high.
[41]	Set digital out D high	Any output with SL output D is high.
[60]	Reset Counter A	Resets Counter A to zero.
[61]	Reset Counter B	Resets Counter B to zero.
[70]	Start Timer 3	See <i>parameter 13-20 SL Controller Timer</i> for further description.
[71]	Start Timer 4	See <i>parameter 13-20 SL Controller Timer</i> for further description.
[72]	Start Timer 5	See <i>parameter 13-20 SL Controller Timer</i> for further description.
[73]	Start Timer 6	See <i>parameter 13-20 SL Controller Timer</i> for further description.
[74]	Start Timer 7	See <i>parameter 13-20 SL Controller Timer</i> for further description.

4.13 Parameters: 14-** Special Functions

4.13.1 14-0* Inverter Switching

14-01 Switching Frequency		
Option:	Function:	
		Select the inverter switching frequency. Changing the switching frequency helps to reduce acoustic noise from the motor.
[0]	Ran3	3 kHz true random PWM (white noise modulation).
[1]	Ran5	5 kHz true random PWM (white noise modulation).
[2]	2.0 kHz	
[3]	3.0 kHz	
[4]	4.0 kHz	
[5]	5.0 kHz	
[6]	6.0 kHz	
[7]	8.0 kHz	
[8]	10.0 kHz	
[9]	12.0 kHz	
[10]	16.0 kHz	

14-03 Overmodulation		
Option:	Function:	
[0]	Off	To avoid torque ripple on the motor shaft, select [0] Off for no overmodulation of the output voltage. This feature may be useful for applications such as grinding machines.
[1] *	On	Select [1] On to enable the overmodulation function for the output voltage. Select this setting when it is required that the output voltage is >95% of the input voltage (typical when running oversynchronously). The output voltage is increased according to the degree of overmodulation. NOTICE Overmodulation leads to increased torque ripple as harmonics are increased.

14-07 Dead Time Compensation Level		
Range:	Function:	
Size related*	[0 - 100]	Level of applied deadtime compensation in percentage. A high level (>90%) optimizes the dynamic motor response; a level 50–90% is good for both motor-torque-ripple minimization and the motor dynamics. A 0-level turns the deadtime compensation off.

14-08 Damping Gain Factor		
Range:	Function:	
Size related*	[0 - 100 %]	Damping factor for DC-link voltage compensation.

14-09 Dead Time Bias Current Level		
Range:	Function:	
Size related*	[0 - 100 %]	Set a bias signal (in [%]) to add to the current-sense signal for deadtime compensation.

4.13.2 14-1* Mains On/Off

Parameters for configuring mains failure monitoring and handling. If a mains failure appears, the frequency converter tries to continue in a controlled way until the power in the DC link is exhausted.

14-10 Mains Failure		
Option:	Function:	
		NOTICE <i>Parameter 14-10 Mains Failure cannot be changed while the motor is running.</i>
		<i>Parameter 14-10 Mains Failure is typically used where short mains interruptions (voltage dips) are present. At 100% load and a short voltage interruption, the DC voltage on the main capacitors drops quickly. For larger frequency converters, it only takes a few milliseconds before the DC level is down to about 373 V DC and the IGBTs cut off and lose control of the motor. When mains is restored, and the IGBTs start again, the output frequency and voltage vector do not correspond to the speed/frequency of the motor, and the result is normally an overvoltage or overcurrent, mostly resulting in a trip lock. Parameter 14-10 Mains Failure can be programmed to avoid this situation.</i>
		Select the function to which the frequency converter must act when the threshold in <i>parameter 14-11 Mains Voltage at Mains Fault</i> has been reached.
[0]	No function	The frequency converter does not compensate for a mains interruption. The voltage on the DC-link drops quickly, and the motor is lost within milliseconds to seconds. Trip lock is the result.
[1]	Ctrl. ramp-down	The frequency converter retains control of the motor and does a controlled ramp down from <i>parameter 14-11 Mains Fault Voltage Level</i> level. If <i>parameter 2-10 Brake Function</i> is [0] Off or [2] AC brake, the ramp follows the overvoltage ramping. If <i>parameter 2-10 Brake Function</i> is [1] Resistor Brake, the ramp follows the setting in

14-10 Mains Failure												
Option:	Function:											
		<i>parameter 3-81 Quick Stop Ramp Time</i> . This selection is useful in pump applications, where the inertia is low and the friction is high. When mains is restored, the output frequency ramps the motor up to the reference speed (if the mains interruption is prolonged, the controlled ramp down might take down the output frequency to 0 RPM, and when the mains is restored, the application is ramped up from 0 RPM to the previous reference speed via the normal ramp up). If the energy in the DC-link disappears before the motor is ramped to 0, the motor is coasted.										
[2]	Ctrl. ramp-down, trip	This selection is similar to selection [1] <i>Ctrl. ramp-down</i> , except that in [2] <i>Ctrl. ramp-down, trip</i> a reset is necessary for starting up after power-up.										
[3]	Coasting	Centrifuges can run for an hour without power supply. In those situations, it is possible to select a coast function at mains interruption, together with a flying start, which occurs when the mains is restored.										
[4]	Kinetic back-up	<p>Kinetic back-up ensures that the frequency converter keeps running as long as there is energy in the system due to the inertia from motor and load. This is done by converting the mechanical energy to the DC-link and thereby maintaining control of the frequency converter and motor. This can extend the controlled operation, depending on the inertia in the system. For fans, it is typically several seconds, for pumps up to 2 s and for compressors only for a fraction of a second. Many industry applications can extend controlled operation for many seconds, which is often enough time for the mains to return.</p> <table border="1"> <tr><td>A</td><td>Normal operation</td></tr> <tr><td>B</td><td>Mains failure</td></tr> <tr><td>C</td><td>Kinetic back-up</td></tr> <tr><td>D</td><td>Mains return</td></tr> <tr><td>E</td><td>Normal operation: Ramping</td></tr> </table> <p>Illustration 4.29 Kinetic Back-up</p> <p>The DC-level during [4] <i>Kinetic back-up</i> is <i>parameter 14-11 Mains Fault Voltage Level</i> x 1.35.</p>	A	Normal operation	B	Mains failure	C	Kinetic back-up	D	Mains return	E	Normal operation: Ramping
A	Normal operation											
B	Mains failure											
C	Kinetic back-up											
D	Mains return											
E	Normal operation: Ramping											

14-10 Mains Failure										
Option:	Function:									
		<p>If the mains does not return, U_{DC} is maintained as long as possible by ramping the speed down towards 0 RPM. Finally, the frequency converter coasts.</p> <p>If mains returns while in kinetic back-up, U_{DC} increases above <i>parameter 14-11 Mains Fault Voltage Level</i> x 1.35. This is detected in 1 of the following ways:</p> <ul style="list-style-type: none"> • If $U_{DC} > \text{parameter 14-11 Mains Fault Voltage Level} \times 1.35 \times 1.05$ • If the speed is above the reference. This is relevant if mains comes back at a lower level than before, for example, <i>parameter 14-11 Mains Fault Voltage Level</i> x 1.35 x 1.02. This does not fulfill the criterion above, and the frequency converter tries to reduce U_{DC} to <i>parameter 14-11 Mains Fault Voltage Level</i> x 1.35 by increasing the speed. This does not succeed as mains cannot be lowered. • If running motoric. The same mechanism as in the previous point, but where the inertia prevents the speed from going above the reference speed. This leads to the motor running motoric until the speed is above the reference speed, and the above situation occurs. Instead of waiting for that, the present criterion is introduced. 								
[5]	Kinetic back-up, trip	<p>The difference between kinetic back-up with and without trip is that the latter always ramps down to 0 RPM and trips, regardless of whether mains return or not.</p> <p>The function is made so that it does not even detect if mains return. This is the reason for the relatively high level on the DC-link during ramp down.</p> <table border="1"> <tr><td>A</td><td>Normal operation</td></tr> <tr><td>B</td><td>Mains failure</td></tr> <tr><td>C</td><td>Kinetic back-up</td></tr> <tr><td>D</td><td>Trip</td></tr> </table> <p>Illustration 4.30 Kinetic Back-up Trip</p>	A	Normal operation	B	Mains failure	C	Kinetic back-up	D	Trip
A	Normal operation									
B	Mains failure									
C	Kinetic back-up									
D	Trip									

14-10 Mains Failure		
Option:	Function:	
[6]	Alarm	
[7]	Kin. back-up, trip w recovery	Kinetic back-up with recovery combines the features of kinetic back-up and kinetic back-up with trip. This feature makes it possible to select between kinetic back-up and kinetic back-up with trip based on a recovery speed, which is configurable in <i>parameter 14-15 Kin. Back-up Trip Recovery Level</i> to enable detection of mains returning. If the mains do not return, the frequency converter ramps down to 0 RPM and trips. If mains return while kinetic back-up is at a speed above the value set in <i>parameter 14-15 Kin. Back-up Trip Recovery Level</i> , normal operation is resumed. This is equal to [4] <i>Kinetic Back-up</i> . The DC level during [7] <i>Kinetic back-up</i> is <i>parameter 14-11 Mains Fault Voltage Level</i> x 1.35. If mains return while kinetic back-up is at a speed below <i>parameter 14-15 Kin. Back-up Trip Recovery Level</i> , the frequency converter ramps down to 0 RPM using the ramp and then trips.

14-11 Mains Fault Voltage Level		
Range:	Function:	
342 V*	[100 - 800 V]	This parameter defines the threshold voltage at which the selected function in <i>parameter 14-10 Mains Failure</i> is activated. Based on the supply quality, consider to select 90% of the nominal mains as the detection level. For a supply of 380 V, <i>parameter 14-11 Mains Fault Voltage Level</i> should be set to 342 V. This results in a DC detection level of 462 V (<i>parameter 14-11 Mains Fault Voltage Level</i> x 1.35).

14-12 Response to Mains Imbalance		
Option:	Function:	
		Operation under severe mains imbalance conditions reduces the lifetime of the motor. Conditions are considered severe if the motor is operated continuously near nominal load (for example, a pump or fan running near full speed).
[0] *	Trip	Trips the frequency converter.
[1]	Warning	Issues a warning.
[2]	Disabled	No action is taken.
[3]	Derate	Derates the frequency converter.

14-15 Kin. Back-up Trip Recovery Level		
Range:	Function:	
Size related*	[0 - 500.000 Reference-FeedbackUnit]	This parameter specifies the kinetic back-up trip recovery level.

4.13.3 14-2* Trip Reset

Parameters for configuring auto reset handling, special trip handling, and control card self test, or initialization.

14-20 Reset Mode		
Option:	Function:	
		<p>⚠ WARNING UNINTENDED START When the frequency converter is connected to AC mains, DC supply, or load sharing, the motor may start at any time. Unintended start during programming, service, or repair work can result in death, serious injury, or property damage. The motor can start via an external switch, a fieldbus command, an input reference signal from the LCP, or after a cleared fault condition. To prevent unintended motor start:</p> <ul style="list-style-type: none"> • Disconnect the frequency converter from the mains. • Press [Off/Reset] on the LCP before programming parameters. • Fully wire and assembly the frequency converter, motor, and any driven equipment before connecting the frequency converter to AC mains, DC supply, or load sharing. <p>NOTICE If the specified number of automatic resets is reached within 10 minutes, the frequency converter enters [0] <i>Manual reset</i> mode. After the manual reset is performed, the setting of <i>parameter 14-20 Reset Mode</i> reverts to the original selection. If the number of automatic resets is not reached within 10 minutes, or when a manual reset is performed, the internal automatic reset counter returns to 0.</p> <p>Select the reset function after tripping. Once reset, the frequency converter can be restarted.</p>
[0] *	Manual reset	Select [0] <i>Manual reset</i> , to perform a reset via [Reset] or via the digital inputs.

14-20 Reset Mode		
Option:	Function:	
[1]	Automatic reset x 1	Select [1]-[12] <i>Automatic reset x 1...x 20</i> to perform between 1 and 20 automatic resets after tripping.
[2]	Automatic reset x 2	
[3]	Automatic reset x 3	
[4]	Automatic reset x 4	
[5]	Automatic reset x 5	
[6]	Automatic reset x 6	
[7]	Automatic reset x 7	
[8]	Automatic reset x 8	
[9]	Automatic reset x 9	
[10]	Automatic reset x 10	
[11]	Automatic reset x 15	
[12]	Automatic reset x 20	
[13]	Infinite auto reset	Select [13] <i>Infinite Automatic Reset</i> for continuous resetting after tripping.
[14]	Reset at power- up	

14-21 Automatic Restart Time		
Range:	Function:	
10 s* [0 - 600 s]	Enter the time interval from trip to start of the automatic reset function. This parameter is active when <i>parameter 14-20 Reset Mode</i> is set to [1]-[13] <i>Automatic reset</i> .	

14-22 Operation Mode		
Option:	Function:	
[0] *	Normal operation	Normal operation with motor selected.
[2]	Initialisation	Reset parameter values to default settings. The frequency converter resets during the next power-up.

14-24 Trip Delay at Current Limit		
Range:	Function:	
60 s* [0 - 60 s]	Enter the current limit trip delay in seconds. When the output current reaches the current limit (<i>parameter 4-18 Current Limit</i>), a warning is triggered. When the current limit warning has been continuously present for the period specified in this parameter, the frequency converter trips. To run continuously in current limit without tripping, set the parameter to 60 s=Off. Thermal monitoring of the frequency converter remains active.	

14-25 Trip Delay at Torque Limit		
Range:	Function:	
60 s* [0 - 60 s]	Enter the torque limit trip delay in seconds. When the output torque reaches the torque limits (<i>parameter 4-16 Torque Limit Motor Mode</i> and <i>parameter 4-17 Torque Limit Generator Mode</i>), a warning is triggered. When the torque limit warning has been continuously present for the period specified in this parameter, the frequency converter trips. Disable the trip delay by setting the parameter to 60 s=Off. Thermal monitoring of the frequency converter remains active.	

14-27 Action At Inverter Fault		
Option:	Function:	
		Select how the frequency converter reacts when an overvoltage or grounding fault occurs.
[0]	Trip	Disable the protection filters and trips at the first fault.
[1] *	Warning	Run the protection filters normally.

14-28 Production Settings		
Option:	Function:	
[0] *	No action	
[1]	Service reset	
[3]	Software Reset	

14-29 Service Code		
Range:	Function:	
0*	[0 - 0x7FFFFFFF]	Only for service technicians use.

4.13.4 14-3* Current Limit Control

The frequency converter features an integral current limit controller, which is activated when the motor current, and thus the torque, is higher than the torque limits set in *parameter 4-16 Torque Limit Motor Mode* and *parameter 4-17 Torque Limit Generator Mode*.

When the current limit is reached during motor operation or regenerative operation, the frequency converter tries to reduce torque below the preset torque limits as quickly as possible without losing control of the motor.

14-30 Current Lim Ctrl, Proportional Gain		
Range:		Function:
100 %*	[0 - 500 %]	Enter the proportional gain value for the current limit controller. Selection of a high value makes the controller react faster. Too high a setting leads to controller instability.

14-31 Current Lim Ctrl, Integration Time		
Range:		Function:
0.020 s*	[0.002 - 2 s]	Control the current limit control integration time. Setting it to a lower value makes it react faster. A setting too low leads to control instability.

14-32 Current Lim Ctrl, Filter Time		
Range:		Function:
5 ms*	[1 - 100 ms]	Set a time constant for the current limit controller low-pass filter.

4.13.5 14-4* Energy Optimizing

Parameters for adjusting the energy optimization level in both variable torque (VT) and automatic energy optimization (AEO) mode in *parameter 1-03 Torque Characteristics*.

14-40 VT Level		
Range:		Function:
66 % *	[40 - 90 %]	<p>NOTICE This parameter cannot be adjusted while the motor is running.</p> <p>NOTICE This parameter is not active when <i>parameter 1-10 Motor Construction</i> is set to options that enable PM motor mode.</p> <p>Enter the level of motor magnetization at low speed. Selection of a low value reduces energy loss in the motor, but also reduces load capability.</p>

14-41 AEO Minimum Magnetisation		
Range:		Function:
66 %*	[40 - 75 %]	Enter the minimum allowable magnetization for AEO. Selection of a low value reduces energy loss in the motor, but can also reduce resistance to sudden load changes.

14-44 d-axis current optimization for IPM		
Range:		Function:
100 %*	[0 - 200 %]	<p>This parameter is available only when <i>parameter 1-10 Motor Construction</i> is set to [3] PM, salient IPM.</p> <p>Normally, VVC⁺ PM control automatically optimizes d-axis demagnetizing current based on d-axis and q-axis settings. When <i>parameter 1-10 Motor Construction</i> is set to [3] PM, salient IPM, use this parameter to compensate the saturation effect at high load. Usually, decreasing this value improves the efficiency. However, 0% means no optimization and the d-axis current is 0 (not recommended).</p>

4.13.6 14-5* Environment

NOTICE

Perform a power cycle after changing any of the parameters in *parameter group 14-5* Environment*.

These parameters help the frequency converter to operate under special environmental conditions.

14-50 RFI Filter		
Option:	Function:	
[0]	Off	
[1]	On	
[2] *	Grid Type	

14-51 DC-Link Voltage Compensation		
Option:	Function:	
[0]	Off	Disable DC-link compensation.
[1] *	On	Enable DC-link compensation.

14-52 Fan Control		
This feature is only available in frequency converters 11–75 kW.		
Option:	Function:	
[5] *	Constant-on mode	
[6]	Constant-off mode	
[7]	On-when-Inverter-is-on-else-off Mode	
[8]	Variable-speed mode	

14-55 Output Filter	
Option:	Function:
	NOTICE This parameter cannot be changed while the motor is running. Select the type of output filter connected.
[0] *	No Filter
[1]	Sine-Wave Filter

4.13.7 14-6* Auto Derate

Use this parameter group to configure automatic derating for the output current of the frequency converter.

14-61 Function at Inverter Overload	
When the frequency converter issues a frequency converter overload warning, select whether to continue and trip the frequency converter, or derate the output current.	
Option:	Function:
[0] *	Trip
[1]	Derate

14-63 Min Switch Frequency	
Option:	Function:
	Set the minimum switch frequency allowed by the output filter.
[2] *	2.0 kHz
[3]	3.0 kHz
[4]	4.0 kHz
[5]	5.0 kHz
[6]	6.0 kHz
[7]	8.0 kHz
[8]	10.0 kHz
[9]	12.0 kHz
[10]	16.0 kHz

14-64 Dead Time Compensation Zero Current Level	
Option:	Function:
[0] *	Disabled
[1]	Enabled If using a long motor cable, select this option to minimize the motor torque ripple.

14-65 Speed Derate Dead Time Compensation	
Range:	Function:
Size related*	[20 - 1000 Hz] Deadtime compensation level is reduced linearly versus output frequency from the maximum level set in <i>parameter 14-07 Dead Time Compensation Level</i> to a minimum level set in this parameter.

4.13.8 14-8* Options

14-89 Option Detection	
Selects the behavior when an option change is detected. This parameter returns to [0] <i>Protect Option Config.</i> after an option change.	
Option:	Function:
[0] *	Protect Option Config. Freezes the current settings and prevents unwanted changes when missing or defective options are detected.
[1]	Enable Option Change Settings can be changed when the system configuration is being modified.

4.13.9 14-9* Fault Settings

Use the parameters to configure the fault settings.

14-90 Fault Level	
Use this parameter to customize fault levels. Use the 8 th element to control the fault level of <i>alarm 13, Overcurrent</i> .	
Option:	Function:
[3] *	Trip Lock Alarm is set to trip lock.
[4]	Trip w. delayed reset Alarm is configured into trip alarm, which can be reset after a delay time. For example, if <i>alarm 13, Overcurrent</i> is configured to this option, it can be reset 3 minutes after the alarm.
[5]	Flystart At start-up, the frequency converter tries to catch a spinning motor. If this option is selected, <i>parameter 1-73 Flying Start</i> is forced to [1] <i>Enabled</i> .

Index	Alarm	Trip lock	Trip w. delayed	Flystart
0	Reserved	-	-	-
1	Reserved	-	-	-
2	Reserved	-	-	-
3	Reserved	-	-	-
4	Reserved	-	-	-
5	Reserved	-	-	-
6	Reserved	-	-	-
7	Overcurrent	D	x	x

Table 4.10 Table for Selection of Action when Selected Alarm Appears (*Parameter 14-90 Fault Level*)

D = Default setting
x = Possible selection

4.14 Parameters: 15-*** Drive Information

4.14.1 15-0* Operating Data

15-00 Operating hours		
Range:	Function:	
0 h* [0 - 0x7ffffff. h]	View how many hours the frequency converter has run. The value is saved, when the frequency converter is turned off.	

15-01 Running Hours		
Range:	Function:	
0 h* [0 - 0x7ffffff. h]	View how many hours the motor has run. Reset the counter in <i>parameter 15-07 Reset Running Hours Counter</i> . The value is saved, when the frequency converter is turned off.	

15-02 kWh Counter		
Range:	Function:	
0 kWh* [0 - 2147483647 kWh]	Register the power consumption of the motor as an average value over 1 hour. Reset the counter in <i>parameter 15-06 Reset kWh Counter</i> .	

15-03 Power Up's		
Range:	Function:	
0* [0 - 2147483647]	View the number of times the frequency converter has been powered up.	

15-04 Over Temp's		
Range:	Function:	
0* [0 - 65535]	View the number of frequency converter temperature faults.	

15-05 Over Volt's		
Range:	Function:	
0* [0 - 65535]	View the number of frequency converter overvoltages.	

15-06 Reset kWh Counter		
Option:	Function:	
[0] * Do not reset	No reset of the kWh counter is required.	
[1] Reset counter	Press [OK] to reset the kWh counter to 0 (see <i>parameter 15-02 kWh Counter</i>).	

15-07 Reset Running Hours Counter		
Option:	Function:	
[0] * Do not reset		
[1] Reset counter	Press [OK] to reset the running hours counter to 0 (see <i>parameter 15-01 Running Hours</i>).	

4.14.2 15-3* Alarm Log

Parameters in this group are array parameters, where up to 10 fault logs can be viewed. 0 is the most recent logged data, and 9 is the oldest. Fault codes and values can be viewed for all logged data.

15-30 Alarm Log: Error Code		
Range:	Function:	
0* [0 - 255]	View the error code and look up its meaning in <i>chapter 6 Troubleshooting</i> .	

15-31 InternalFaultReason		
Range:	Function:	
0* [-32767 - 32767]	View an extra description of the error. This parameter is mostly used in combination with <i>alarm 38, Internal Fault</i> .	

4.14.3 15-4* Drive Identification

Parameters containing read-only information about the hardware and software configuration of the frequency converter.

15-40 FC Type		
Range:	Function:	
0* [0 - 0]	View the frequency converter type. The readout is identical to the power field of the type code definition, characters 1–6.	

15-41 Power Section		
Range:	Function:	
0* [0 - 20]	View the FC type. The readout is identical to the power field of the type code definition, characters 7–10.	

15-42 Voltage		
Range:	Function:	
0* [0 - 20]	View the FC type. The readout is identical to the power field type of the type code definition, characters 11–12.	

15-43 Software Version		
Range:	Function:	
0* [0 - 5]	View the combined SW version (or package version) consisting of power SW and control SW.	

15-44 Ordered Typecode String		
Range:	Function:	
0* [0 - 40]	View the type code string used for reordering the frequency converter in its original configuration.	

15-45 Actual Typecode String		
Range:	Function:	
0*	[0 - 40]	View the actual type code.

15-46 Drive Ordering No		
Range:	Function:	
0*	[0 - 0]	View the 8-digit ordering number used for reordering the frequency converter in its original configuration.

15-47 Power Card Ordering No		
Range:	Function:	
0*	[0 - 8]	View the power card ordering number.

15-48 LCP Id No		
Range:	Function:	
0*	[0 - 20]	View the LCP ID number.

15-49 SW ID Control Card		
Range:	Function:	
0*	[0 - 20]	View the control card software version number.

15-50 SW ID Power Card		
Range:	Function:	
0*	[0 - 20]	View the power card software version number.

15-51 Frequency Converter Serial Number		
Range:	Function:	
0*	[0 - 10]	View the frequency converter serial number.

15-53 Power Card Serial Number		
Range:	Function:	
0*	[0 - 19]	View the power card serial number.

4.14.4 15-6* Option Ident.

This read-only parameter group contains information about the hardware and software configuration of the options installed in slots A, B, C0, and C1.

15-60 Option Mounted		
Range:	Function:	
Size related*	[0 - 30]	View the installed option type.

15-61 Option SW Version		
Range:	Function:	
Size related*	[0 - 20]	View the installed option software version.

15-62 Option Ordering No		
Range:	Function:	
Size related*	[0 - 8]	Shows the ordering number for the installed options.

15-63 Option Serial No		
Range:	Function:	
Size related*	[0 - 18]	View the installed option serial number.

15-70 Option in Slot A		
Range:	Function:	
0*	[0 - 30]	View the type code string for the option A, and a translation of the type code string.

15-71 Slot A Option SW Version		
Range:	Function:	
0*	[0 - 20]	View the software version for the option A.

4.14.5 15-9* Parameter Info

Use this parameter group to view information about available parameters for the frequency converter.

15-92 Defined Parameters		
Range:	Function:	
0*	[0 - 2000]	View a list of all defined parameters in the frequency converter. The list ends with 0.

15-97 Application Type		
Range:	Function:	
0*	[0 - 0xFFFFFFFF]	This parameter contains data used by MCT-10 Set-up Software.

15-98 Drive Identification		
Range:	Function:	
0*	[0 - 56]	This parameter contains data used by MCT-10 Set-up Software.

15-99 Parameter Metadata		
Range:	Function:	
0*	[0 - 9999]	This parameter contains data used by MCT-10 Set-up Software.

4.15 Parameters: 16-*** Data Readouts

4.15.1 16-0* General Status

16-00 Control Word		
Range:	Function:	
0*	[0 - 65535]	View the control word sent from the frequency converter via the serial communication port in hex code.

16-01 Reference [Unit]		
Range:	Function:	
0 ReferenceFeed-backUnit*	[-4999 - 4999 ReferenceFeed-backUnit]	View the present reference value applied on impulse or analog basis in the unit resulting from the configuration selected in <i>parameter 1-00 Configuration Mode</i> .

16-02 Reference [%]		
Range:	Function:	
0 %*	[-200 - 200 %]	View the total reference. The total reference is the sum of digital, analog, preset, bus, and freeze references, plus catch up and slow down.

16-03 Status Word		
Range:	Function:	
0*	[0 - 65535]	View the status word sent from the frequency converter via the serial communication port in hex code.

16-05 Main Actual Value [%]		
Range:	Function:	
0 %*	[-200 - 200 %]	View the 2-byte word sent with the status word to the bus master reporting the main actual value.

16-09 Custom Readout		
Range:	Function:	
0 CustomReadoutUnit*	[0 - 9999 CustomReadoutUnit]	View the custom readout from <i>parameter 0-30 Custom Readout Unit</i> to <i>parameter 0-32 Custom Readout Max Value</i> .

4.15.2 16-1* Motor Status

16-10 Power [kW]		
Range:	Function:	
0 kW*	[0 - 1000 kW]	Shows motor power in kW. The calculated value shown is based on the actual motor voltage and motor current. The value is filtered, and therefore approximately 300 ms may pass from when an input value changes to when the data readout values change. The resolution of readout value on fieldbus is in 10 W steps.

16-11 Power [hp]		
Range:	Function:	
0 hp*	[0 - 1000 hp]	View the motor power in hp. The value shown is calculated on the basis of the actual motor voltage and motor current. The value is filtered, and therefore approximately 300 ms may pass from when an input value changes to when the data readout values change.

16-12 Motor Voltage		
Range:	Function:	
0 V*	[0 - 65535 V]	View the motor voltage. A calculated value is used for controlling the motor.

16-13 Frequency		
Range:	Function:	
0 Hz*	[0 - 6553.5 Hz]	View the motor frequency, without resonance dampening.

16-14 Motor current		
Range:	Function:	
0 A*	[0 - 655.35 A]	View the motor current measured as an average value, I_{RMS} . The value is filtered, and approximately 200 ms may pass from when an input value changes to when the data readout values change.

16-15 Frequency [%]		
Range:	Function:	
0 %*	[0 - 6553.5 %]	View a 2-byte word reporting the actual motor frequency (without resonance dampening) as a percentage (scale 0000-4000 hex) of <i>parameter 4-19 Max Output Frequency</i> .

16-16 Torque [Nm]		
Range:	Function:	
0 Nm	[-30000 - 30000 Nm]	View the torque value with sign, applied to the motor shaft. Some motors supply more than 160% torque. As a result, the minimum value and the maximum value depend on the maximum motor current as well as the motor used.

16-17 Speed [RPM]		
Range:	Function:	
0 RPM	[-30000 - 30000 RPM]	View the actual motor RPM. In open-loop or closed-loop process control, the motor RPM is estimated. In speed closed-loop modes, the motor RPM is measured.

16-18 Motor Thermal		
Range:	Function:	
0 %*	[0 - 100 %]	View the calculated thermal load on the motor. The cutout limit is 100%. The basis for calculation is the ETR function selected in <i>parameter 1-90 Motor Thermal Protection</i> .

16-22 Torque [%]		
Range:	Function:	
0 %*	[-200 - 200 %]	View the torque in percent of nominal torque, with sign, applied to the motor shaft.

4.15.3 16-3* Drive Status

16-30 DC Link Voltage		
Range:	Function:	
0 V*	[0 - 65535 V]	View a measured value. The value is filtered with a 128 ms time constant.

16-33 Brake Energy Average		
Range:	Function:	
0 kW*	[0 - 10000 kW]	View the brake power transmitted to an external brake resistor. The mean power is calculated on an average level based on the latest 120 s.

16-34 Heatsink Temp.		
Range:	Function:	
0 °C*	[-128 - 127 °C]	View the frequency converter heat sink temperature. The cutout limit is 90 ±5 °C [194 °F], and the motor cuts back in at 60 ±5 °C [140 °F].

16-35 Inverter Thermal		
Range:	Function:	
0 %*	[0 - 255 %]	View the percentage load on the inverter.

16-36 Inv. Nom. Current		
Range:	Function:	
0 A*	[0 - 655.35 A]	View the inverter nominal current, which should match the nameplate data on the connected motor. The data is used for calculation of torque and motor protection.

16-37 Inv. Max. Current		
Range:	Function:	
0 A*	[0 - 655.35 A]	View the inverter maximum current, which should match the nameplate data on the connected motor. The data is used for calculation of torque and motor protection.

16-38 SL Controller State		
Range:	Function:	
0*	[0 - 20]	View the state of the event under execution by the SL controller.

16-39 Control Card Temp.		
Range:	Function:	
0 °C*	[0 - 65535 °C]	View the temperature on the control card, stated in °C.

4.15.4 16-5* Ref. & Feedb.

16-50 External Reference		
Range:	Function:	
0 %*	[-200 - 200 %]	View the total reference, the sum of digital, analog, preset, bus, and freeze references, plus catch up and slow down.

16-52 Feedback[Unit]		
Range:	Function:	
0 ProcessCtrlUnit*	[-4999 - 4999 ProcessCtrlUnit]	View the feedback unit resulting from the selection of unit and scaling in <i>parameter 3-00 Reference Range</i> , <i>parameter 3-01 Reference/Feedback Unit</i> , <i>parameter 3-02 Minimum Reference</i> , and <i>parameter 3-03 Maximum Reference</i> .

16-53 Digi Pot Reference		
Range:	Function:	
0*	[-200 - 200]	View the contribution of the digital potentiometer to the actual reference.

16-57 Feedback [RPM]		
Range:	Function:	
0 RPM* [-30000 - 30000 RPM]	Readout parameter where the actual motor RPM from the feedback source can be read in both closed loop and open loop. The feedback source is selected in <i>parameter 7-00 Speed PID Feedback Source</i> .	

4.15.5 16-6* Inputs and Outputs

16-60 Digital Input		
Range:	Function:	
0* [0 - 65535]	View the actual state of the digital inputs 18, 19, 27, and 29.	
	Bit 0	Digital input terminal 33
	Bit 1	Digital input terminal 32
	Bit 2	Digital input terminal 29
	Bit 3	Digital input terminal 27
	Bit 4	Digital input terminal 19
	Bit 5	Digital input terminal 18
	Bit 10	Digital input terminal 31
Table 4.11 Bits Definition		

16-61 Terminal 53 Setting		
Option:	Function:	
		View the setting of input terminal 53.
[0]	Current mode	
[1]	Voltage mode	

16-62 Analog input 53		
Range:	Function:	
1* [0 - 20]	View the actual value at input 53.	

16-63 Terminal 54 Setting		
Option:	Function:	
		View the setting of input terminal 54.
[0]	Current mode	
[1]	Voltage mode	

16-64 Analog input 54		
Range:	Function:	
1* [0 - 20]	View the actual value at input 54.	

16-65 Analog output 42 [mA]		
Range:	Function:	
0 mA* [0 - 20 mA]	View the actual value at output 42. The value shown reflects the selections in <i>parameter 6-90 Terminal 42 Mode</i> and <i>parameter 6-91 Terminal 42 Analog Output</i> .	

16-66 Digital Output		
Range:	Function:	
0* [0 - 15]	View the binary value of all digital outputs.	
	Bit 2	Digital output terminal 29
	Bit 3	Digital output terminal 27
	Bit 4	Digital output terminal 45
	Bit 5	Digital output terminal 42
Table 4.12 Bits Definition		

16-67 Pulse input 29 [Hz]		
Range:	Function:	
0* [0 - 130000]	View the actual frequency rate on terminal 29.	

16-68 Pulse input 33 [Hz]		
Range:	Function:	
0* [0 - 130000]	View the actual value of the frequency applied at terminal 33 as an impulse input.	

16-69 Pulse output 27 [Hz]		
Range:	Function:	
0* [0 - 40000]	View the actual value of impulses applied to terminal 27 in digital output mode.	

16-70 Pulse output 29 [Hz]		
Range:	Function:	
0* [0 - 40000]	View the actual value of pulses to terminal 29 in digital output mode.	

16-71 Relay output		
Range:	Function:	
0* [0 - 65535]	View the settings of all relays.	
	Bit 3	User relay 02
	Bit 4	User relay 01
Table 4.13 Bits Definition		

16-72 Counter A		
Range:	Function:	
0* [-32768 - 32767]	View the present value of counter A. Counters are useful as comparator operands, see <i>parameter 13-10 Comparator Operand</i> . The value can be reset or changed either via digital inputs (<i>parameter group 5-1* Digital Inputs</i>), or by using an SLC action (<i>parameter 13-52 SL Controller Action</i>).	

16-73 Counter B		
Range:	Function:	
0* [-32768 - 32767]	View the present value of counter B. Counters are useful as comparator operands (<i>parameter 13-10 Comparator Operand</i>). The value can be reset or changed either via digital inputs (<i>parameter group 5-1* Digital Inputs</i>) or by using an SLC action (<i>parameter 13-52 SL Controller Action</i>).	

16-79 Analog output 45 [mA]		
Range:	Function:	
0 mA* [0 - 20 mA]	View the actual value at output 45 in mA. The value shown reflects the selection in <i>parameter 6-70 Terminal 45 Mode</i> and <i>parameter 6-71 Terminal 45 Analog Output</i> .	

4.15.6 16-8* Fieldbus & FC Port

Parameters for reporting the bus references and control words.

16-80 Fieldbus CTW 1		
Range:	Function:	
0* [0 - 65535]	View the 2-byte control word (CTW) received from the bus master. Interpretation of the CTW depends on the fieldbus option installed and the CTW profile selected in <i>parameter 8-10 Control Word Profile</i> . For more information, see relevant fieldbus manuals.	

16-82 Fieldbus REF 1		
Range:	Function:	
0* [-32768 - 32767]	To set the reference value, view the 2-byte word sent with the control word from the bus master. For more information, refer to the relevant fieldbus manual.	

16-84 Comm. Option STW		
Range:	Function:	
0* [0 - 65535]	View the extended fieldbus communication option status word. For more information, refer to the relevant fieldbus manual.	

16-85 FC Port CTW 1		
Range:	Function:	
1084* [0 - 65535]	View the 2-byte control word (CTW) received from the bus master. Interpretation of the control word depends on the fieldbus option installed and the control word profile selected in <i>parameter 8-10 Control Word Profile</i> .	

16-86 FC Port REF 1		
Range:	Function:	
0* [-32768 - 32767]	View the last received reference from the FC port.	

4.15.7 16-9* Diagnosis Readouts

Use the parameters to display alarm, warning, and extended status words.

16-90 Alarm Word		
Range:	Function:	
0* [0 - 0xFFFFFFFFFUL]	View the alarm word sent via the serial communication port in hex code.	

16-91 Alarm Word 2		
Range:	Function:	
0* [0 - 0xFFFFFFFFFUL]	View the alarm word 2 sent via the serial communication port in hex code.	

16-92 Warning Word		
Range:	Function:	
0* [0 - 0xFFFFFFFFFUL]	View the warning word sent via the serial communication port in hex code.	

16-93 Warning Word 2		
Range:	Function:	
0* [0 - 0xFFFFFFFFFUL]	View the warning word 2 sent via the serial communication port in hex code.	

16-94 Ext. Status Word		
Range:	Function:	
0* [0 - 0xFFFFFFFFFUL]	Return the extended status word sent via the serial communication port in hex code.	

16-95 Ext. Status Word 2		
Range:	Function:	
0* [0 - 0xFFFFFFFFFUL]	Return the extended status word 2 sent via the serial communication port in hex code.	

16-97 Alarm Word 3		
Range:	Function:	
0* [0 - 0xFFFFFFFFFUL]	Show the alarm word 3 sent via the serial communication port in hex code.	

4.16 Parameters: 17-** Feedback Options

4.16.1 17-1* Inc.Enc.Interface

17-10 Signal Type		
Select the incremental type (A/B channel) of the encoder in use. Find the information on the encoder datasheet.		
Option:	Function:	
[0]	None	
[1] *	RS422 (5V TTL)	
[2]	Sinusoidal 1Vpp	

17-11 Resolution (PPR)		
Range:	Function:	
1024*	[10 - 10000]	Enter the resolution of the incremental track, which is the number of pulses or periods per revolution.

4.16.2 17-5* Resolver Interface

17-50 Poles		
Range:	Function:	
2*	[2 - 2]	

17-51 Input Voltage		
Range:	Function:	
7 V*	[2 - 8 V]	

17-52 Input Frequency		
Range:	Function:	
10 kHz*	[2 - 15 kHz]	

17-53 Transformation Ratio		
Range:	Function:	
0.5*	[0.1 - 1.1]	

17-56 Encoder Sim. Resolution		
Option:	Function:	
[0] *	Disabled	
[1]	512	
[2]	1024	
[3]	2048	
[4]	4096	

17-59 Resolver Interface		
Option:	Function:	
[0] *	Disabled	
[1]	Enabled	

4.16.3 17-6* Monitoring and App.

17-60 Feedback Direction		
Option:	Function:	
[0] *	Clockwise	
[1]	Counter clockwise	

17-61 Feedback Signal Monitoring		
Option:	Function:	
[0]	Disabled	
[1] *	Warning	
[2]	Trip	
[3]	Jog	
[4]	Freeze Output	
[5]	Max Speed	
[6]	Switch to Open Loop	

4.17 Parameters: 18-** Data Readouts 2

4.17.1 18-8* Center Winder Readout

18-81 Tension PID Output		
Range:	Function:	
0 Hz*	[-5000 - 5000 Hz]	Read-only parameter used to show the output of the tension loop PID.

18-82 Center Winder Output		
Range:	Function:	
0 Hz*	[-5000 - 5000 Hz]	Read-only parameter used to display the output of the tension loop PID.

18-83 Line Speed		
Range:	Function:	
0 Hz*	[-5000 - 5000 Hz]	Read-only parameter used to display the output of the tension loop PID.

18-84 Diameter		
Range:	Function:	
0 %*	[0 - 100 %]	Read-only parameter that is used to display the diameter of the roll.

18-85 Tapered Tension Set Point		
Range:	Function:	
0 %*	[0 - 100 %]	Read-only parameter used to display the tapered tension set point.

18-86 Tension Feedback		
Range:	Function:	
0 %*	[0 - 100 %]	Read-only parameter used to display the actual tension feedback.

4.17.2 18-9* PID Readouts

18-90 Process PID Error		
Range:	Function:	
0 %* [-200 - 200 %]	Give the present error value used by the process PID controller.	

18-91 Process PID Output		
Range:	Function:	
0 %* [-200 - 200 %]	Give the present raw output value from the process PID controller.	

18-92 Process PID Clamped Output		
Range:	Function:	
0 %* [-200 - 200 %]	Give the present output value from the process PID controller after the clamp limits have been observed.	

18-93 Process PID Gain Scaled Output		
Range:	Function:	
0 %* [-200 - 200 %]	Give the present output value from the process PID controller after the clamp limits have been observed, and the resulting value has been gain scaled.	

4.18 Parameters: 21-*** Ext. Closed Loop

4.18.1 21-0* Ext. CL Autotuning

21-09 Extended PID Enable		
Select the extended CL PID controller that is to be autotuned.		
Option:	Function:	
[0] *	Disabled	
[1]	Enabled Ext CL1 PID	

4.18.2 21-1* Ext. Closed-loop Reference/feedback

21-11 Ext. 1 Minimum Reference		
Range:	Function:	
0 ExtPID1Unit* [-999999.999 - 999999.999 ExtPID1Unit]	This parameter sets the minimum value that can be obtained by the sum of the setpoint and reference.	

21-12 Ext. 1 Maximum Reference		
Range:	Function:	
100 ExtPID1Unit [-999999.999 - 999999.999 ExtPID1Unit]	This parameter sets the maximum value that can be obtained by the sum of the setpoint and reference.	

21-13 Ext. 1 Reference Source		
This parameter defines which input on the frequency converter should be treated as the source of the reference signal.		
Option:	Function:	
[0] *	No function	
[1]	Analog Input 53	
[2]	Analog Input 54	
[7]	Frequency input 29	
[8]	Frequency input 33	

21-14 Ext. 1 Feedback Source		
This parameter defines which input on the frequency converter should be treated as the source of the feedback signal.		
Option:	Function:	
[0] *	No function	
[1]	Analog Input 53	
[2]	Analog Input 54	
[3]	Frequency input 29	
[4]	Frequency input 33	

21-15 Ext. 1 Setpoint		
Range:	Function:	
0 ExtPID1Unit* [-999999.999 - 999999.999 ExtPID1Unit]	This parameter is used as the reference for comparing feedback values. The setpoint can be offset with digital, analog, or bus references.	

21-17 Ext. 1 Reference [Unit]		
Range:	Function:	
0 ExtPID1Unit* [-999999.999 - 999999.999 ExtPID1Unit]	Return the resulting reference value.	

21-18 Ext. 1 Feedback [Unit]		
Range:	Function:	
0 ExtPID1Unit* [-999999.999 - 999999.999 ExtPID1Unit]	Return the feedback value.	

21-19 Ext. 1 Output [%]		
Range:	Function:	
0 %* [0 - 100 %]	Return the extended closed loop 1 PID controller output value.	

21-20 Ext. 1 Normal/Inverse Control		
Select [0] <i>Normal</i> if the controller output should be reduced when the feedback is higher than the reference. Select [1] <i>Inverse</i> if the output should be increased when the feedback is higher than the reference.		
Option:	Function:	
[0] *	Normal	
[1]	Inverse	

4

21-21 Ext. 1 Proportional Gain		
Range:	Function:	
0.01*	[0 - 10]	The proportional gain indicates the number of times the error between the setpoint and the feedback signal is to be applied.

21-22 Ext. 1 Integral Time		
Range:	Function:	
10000 s*	[0.01 - 10000 s]	The integrator provides an increasing gain at a constant error between the setpoint and the feedback signal. The integral time is the time needed by the integrator to reach the same gain as the proportional gain.

21-23 Ext. 1 Differentiation Time		
Range:	Function:	
0 s*	[0 - 10 s]	The differentiator does not react to a constant error. It only provides a gain when the error changes. The quicker the error changes, the stronger the gain from the differentiator.

21-24 Ext. 1 Dif. Gain Limit		
Range:	Function:	
5*	[1 - 50]	Set a limit for the differentiator gain (DG). The DG increases if there are fast changes. Limit the DG to obtain a pure differentiator gain at slow changes and a constant differentiator gain where quick changes occur.

4.19 Parameters: 22-*** Application Functions

22-02 Sleepmode CL Control Mode		
This parameter is used to set whether feedback is detected for entering sleep mode in process closed loop.		
Option:	Function:	
[0] *	Normal	Detect feedback together with other parameters.
[1]	Simplified	Do not detect feedback. Only check sleep speed and time.

- When the error between reference and feedback is greater than *parameter 22-44 Wake-Up Ref./FB Diff*, and the condition lasts more than *parameter 22-41 Minimum Sleep Time*, the frequency converter is out of sleep mode.
- The frequency converter reverts to closed-loop control.

NOTICE

Sleep mode is not active when local reference is active (set speed manually with navigation keys on the LCP). Does not work in hand-on mode. Auto set-up in open loop must be carried out before setting input/output in closed loop.

4.19.1 22-4* Sleep Mode

The sequence when running sleep mode in open loop:

- The motor speed is less than *parameter 22-47 Sleep Speed [Hz]* and the motor has been running longer than *parameter 22-40 Minimum Run Time*.
- The frequency converter ramps the motor speed down to *parameter 1-82 Min Speed for Function at Stop [Hz]*.
- The frequency converter activates *parameter 1-80 Function at Stop*. The frequency converter is now in sleep mode.
- The frequency converter compares the speed setpoint with *parameter 22-43 Wake-Up Speed [Hz]* to detect wake-up situation.
- The speed setpoint is greater than *parameter 22-43 Wake-Up Speed [Hz]* and the sleep condition has last for more than *parameter 22-41 Minimum Sleep Time*. The frequency converter is now out of sleep mode.
- Go back to speed open-loop control (ramp motor speed up to the speed setpoint).

The sequence when running sleep mode in closed loop:

- If *parameter 20-81 PI Normal/ Inverse Control=[0] Normal*. When error between reference and feedback is greater than *parameter 22-44 Wake-Up Ref./FB Diff*, the frequency converter enters boost status. If *parameter 22-45 Setpoint Boost* is not set, the frequency converter enters sleep mode.
- After *parameter 22-46 Maximum Boost Time*, the frequency converter ramps the motor speed down to *parameter 1-82 Min Speed for Function at Stop [Hz]*.
- The frequency converter activates *parameter 1-80 Function at Stop*. The frequency converter is now in sleep mode.

22-40 Minimum Run Time		
Range:	Function:	
10 s*	[0 - 600 s]	Set the wanted minimum running time for the motor after a start command (digital input or bus) before entering sleep mode.

22-41 Minimum Sleep Time		
Range:	Function:	
10 s*	[0 - 600 s]	Set the minimum time for staying in sleep mode. This time overrides any wake-up conditions.

22-43 Wake-Up Speed [Hz]		
Range:	Function:	
10*	[0 - 400.0]	Only to be used if <i>parameter 1-00 Configuration Mode</i> is set to [0] Open loop, and an external controller applies speed reference. Set the reference speed at which the sleep mode should be deactivated. The wake-up speed must not exceed the setting in <i>parameter 4-14 Motor Speed High Limit [Hz]</i> .

22-44 Wake-Up Ref./FB Diff		
Range:	Function:	
10 % *	[0 - 100 %]	Only to be used if <i>parameter 1-00 Configuration Mode</i> is set to [1] Closed loop, and the integrated PI controller is used for controlling the pressure. Set the pressure drop allowed in percentage of setpoint for the pressure (P _{set}) before canceling the sleep mode.

22-45 Setpoint Boost		
Range:	Function:	
0 % * - 100 %]	Only to be used if <i>parameter 1-00 Configuration Mode</i> is set for [1] <i>Closed loop</i> , and the integrated PI controller is used. In systems with for example constant pressure control, it is advantageous to increase the system pressure before the motor is stopped. This extends the time in which the motor is stopped and helps to avoid frequent start/stop. Set the desired overpressure/temperature in percentage of setpoint for the pressure (P_{set})/ temperature before entering the sleep mode. If setting for 5%, the boost pressure is $P_{set} \times 1.05$. The negative values can be used for cooling tower control where a negative change is needed.	

22-46 Maximum Boost Time		
Range:	Function:	
60 s* [0 - 600 s]	Only to be used when <i>parameter 1-00 Configuration Mode</i> is set for [1] <i>Closed loop</i> , and the integrated PI controller is used for controlling the pressure. Set the maximum time for which boost mode is allowed. If the set time is exceeded, sleep mode is entered, not waiting for the set boost pressure to be reached.	

22-47 Sleep Speed [Hz]		
Range:	Function:	
0* [0 - 400.0]	Set the speed below which the frequency converter goes into sleep mode. The sleep speed must not exceed the setting in <i>parameter 22-43 Wake-Up Speed [Hz]</i> .	

22-48 Sleep Delay Time		
Range:	Function:	
0 s* [0 - 3600 s]	Set the delay time that the motor waits before entering sleep mode when the condition to enter sleep mode is met.	

22-49 Wake-Up Delay Time		
Range:	Function:	
0 s* [0 - 3600 s]	Set the delay time that the motor waits before waking up from sleep mode when the condition to wake up is met.	

4.19.2 22-6* Broken-belt Detection

Use broken-belt detection in both closed-loop systems and open-loop systems for pumps and fans. If the estimated motor torque (current) is below the broken-belt torque (current) value (*parameter 22-61 Broken Belt Torque*), and the frequency converter output frequency is above or equal to 15 Hz, *parameter 22-60 Broken Belt Function* is performed.

22-60 Broken Belt Function		
Option:	Function:	
	Select the actions to be performed if the broken-belt condition is detected.	
[0] * Off		
[1] Warning	The frequency converter continues to run, but activates <i>warning 95, Broken belt</i> . A frequency converter digital output or a serial communication bus communicates a warning to other equipment.	
[2] Trip	The frequency converter stops running and activates <i>alarm 95, Broken belt</i> . A frequency converter digital output or a serial communication bus communicates an alarm to other equipment.	

22-61 Broken Belt Torque		
Range:	Function:	
10 %* [5 - 100 %]	Set the broken-belt torque as a percentage of the rated motor torque.	

22-62 Broken Belt Delay		
Range:	Function:	
10 s* [0 - 600 s]	Set the time for which the broken-belt conditions must be active before carrying out the action selected in <i>parameter 22-60 Broken Belt Function</i> .	

4.20 Parameters: 30-** Special Features

4.20.1 30-2* Adv. Start Adjust

30-20 High Starting Torque Time [s]		
Range:	Function:	
Size related*	[0 - 60 s]	High starting torque time for PM motors in VVC ⁺ mode without feedback.

30-21 High Starting Torque Current [%]		
Range:	Function:	
Size related*	[0 - 200.0 %]	High starting torque current for PM motors in VVC ⁺ mode without feedback.

30-22 Locked Rotor Protection		
Option:	Function:	
[0] *	Off	
[1]	On	The locked rotor protection for PM motors.

30-23 Locked Rotor Detection Time [s]		
Range:	Function:	
0.10 s*	[0.05 - 1 s]	The locked rotor detection time for PM motors.

4.21 Parameters: 32-** Motion Control Basic Settings

32-11 User Unit Denominator		
Range:	Function:	
1*	[1 - 65535]	All target positions are made in user units and are converted to quad-counts internally. By selecting scaling units, it is possible to work with any measurement unit (for example mm). This factor consists of a numerator and denominator.

32-12 User Unit Numerator		
Range:	Function:	
1*	[1 - 65535]	All target positions are made in user units and are converted to quad-counts internally. By selecting scaling units, it is possible to work with any measurement unit (for example mm). This factor consists of a numerator and denominator.

32-67 Max. Tolerated Position Error		
Range:	Function:	
2000000*	[1 - 2147483648]	This parameter defines the maximum error allowed between the actual position and the calculated command position. If the actual error exceeds the value set in this parameter, the position-control-fault alarm is triggered.

32-80 Maximum Allowed Velocity		
Range:	Function:	
1500 RPM*	[1 - 30000 RPM]	This parameter defines the maximum velocity in RPM during motion control.

32-81 Motion Ctrl Quick Stop Ramp		
Range:	Function:	
1000 ms*	[50 - 3600000 ms]	This parameter defines the quick-stop ramp time from the maximum allowed velocity to 0 for motion control.

4.22 Parameters: 33-** Motion Control Adv. Settings

33-00 Homing Mode		
Select the homing mode.		
Option:	Function:	
[0] *	Not forced	
[1]	Forced manual homing	
[2]	Forced automated homing	

33-01 Home Offset		
Range:	Function:	
0*	[-1073741824 - 1073741824]	Use this parameter to set an offset of 0 (home position) compared to the position after homing.

33-02 Home Ramp Time		
Range:	Function:	
10 ms*	[1 - 1000 ms]	This parameter defines the ramp time (in ms) from standstill to the value set in <i>parameter 32-80 Maximum Allowed Velocity</i> .

33-03 Homing Velocity		
Range:	Function:	
100 RPM*	[-1500 - 1500 RPM]	This parameter defines the velocity of homing. It must not exceed the <i>parameter 32-80 Maximum Allowed Velocity</i> .

33-04 Homing Behaviour		
Option:	Function:	
		Define the behavior when the home switch is found: Reversing without index (0 pulse) search, or forwarding without index search.
[1] *	Reverse no index	
[3]	Forward no index	

33-41 Negative Software Limit		
Range:	Function:	
-500000* [-1073741824 - 1073741824]		This parameter is active only during positioning if <i>parameter 33-43 Negative Software Limit Active</i> is set to [1] Active. When <i>parameter 34-50 Actual Position</i> reaches below the negative software limit set in this parameter, a <i>position control fault</i> alarm is reported.

33-42 Positive Software Limit		
Range:	Function:	
500000* [-1073741824 - 1073741824]		This parameter is active only during positioning if <i>parameter 33-44 Positive Software Limit Active</i> is set to [1] Active. When <i>parameter 34-50 Actual Position</i> reaches above the positive software limit set in this parameter, a <i>position control fault</i> alarm is reported.

33-43 Negative Software Limit Active		
Option:	Function:	
[0] *	Inactive	
[1]	Active	When this parameter is set to active, the frequency converter continuously checks whether the target position is below the negative software limit. If it occurs, an error is issued and the frequency converter control is switched off.

33-44 Positive Software Limit Active		
Option:	Function:	
[0] *	Inactive	
[1]	Active	When this parameter is set to active, the frequency converter continuously checks whether the target position is above the positive software limit. If it occurs, an error is issued and the frequency converter control is switched off.

33-47 Target Position Window		
Range:	Function:	
512*	[1 - 10000]	Defines the size of the target window with user unit. A position is only viewed as reached when the actual position is within this window.

4.23 Parameters: 34-** Motion Control Data Readouts

4.23.1 34-0* PCD Writer Par.

Parameters for readout of fieldbus data received from fieldbus master.

34-01 PCD 1 Write For Application		
Range:	Function:	
0*	[0 - 65535]	Value received in PCD1 of fieldbus telegram.

34-02 PCD 2 Write For Application		
Range:	Function:	
0*	[0 - 65535]	Value received in PCD2 of fieldbus telegram.

34-03 PCD 3 Write For Application		
Range:	Function:	
0*	[0 - 65535]	Value received in PCD3 of fieldbus telegram.

34-04 PCD 4 Write For Application		
Range:	Function:	
0*	[0 - 65535]	Value received in PCD4 of fieldbus telegram.

34-05 PCD 5 Write For Application		
Range:	Function:	
0*	[0 - 65535]	Value received in PCD5 of fieldbus telegram.

34-06 PCD 6 Write For Application		
Range:	Function:	
0*	[0 - 65535]	Value received in PCD6 of fieldbus telegram.

34-07 PCD 7 Write For Application		
Range:	Function:	
0*	[0 - 65535]	Value received in PCD7 of fieldbus telegram.

34-08 PCD 8 Write For Application		
Range:	Function:	
0*	[0 - 65535]	Value received in PCD8 of fieldbus telegram.

34-09 PCD 9 Write For Application		
Range:	Function:	
0*	[0 - 65535]	Value received in PCD9 of fieldbus telegram.

34-10 PCD 10 Write For Application		
Range:	Function:	
0*	[0 - 65535]	Value received in PCD10 of fieldbus telegram.

4.23.2 34-2* PCD Read Par.

Parameters for readout of fieldbus data sent to the fieldbus master.

34-21 PCD 1 Read For Application		
Range:	Function:	
0* [0 - 65535]	Value sent in PCD1 of fieldbus telegram.	

34-22 PCD 2 Read For Application		
Range:	Function:	
0* [0 - 65535]	Value sent in PCD2 of fieldbus telegram.	

34-23 PCD 3 Read For Application		
Range:	Function:	
0* [0 - 65535]	Value sent in PCD3 of fieldbus telegram.	

34-24 PCD 4 Read For Application		
Range:	Function:	
0* [0 - 65535]	Value sent in PCD4 of fieldbus telegram.	

34-25 PCD 5 Read For Application		
Range:	Function:	
0* [0 - 65535]	Value sent in PCD5 of fieldbus telegram.	

34-26 PCD 6 Read For Application		
Range:	Function:	
0* [0 - 65535]	Value sent in PCD6 of fieldbus telegram.	

34-27 PCD 7 Read For Application		
Range:	Function:	
0* [0 - 65535]	Value sent in PCD7 of fieldbus telegram.	

34-28 PCD 8 Read For Application		
Range:	Function:	
0* [0 - 65535]	Value sent in PCD8 of fieldbus telegram.	

34-29 PCD 9 Read For Application		
Range:	Function:	
0* [0 - 65535]	Value sent in PCD9 of fieldbus telegram.	

34-30 PCD 10 Read For Application		
Range:	Function:	
0* [0 - 65535]	Value sent in PCD10 of fieldbus telegram.	

4.23.3 34-5* Process Data

Readout of process data for motion control.

34-50 Actual Position		
Range:	Function:	
0* [-1073741824 - 1073741824]	The actual position in user unit.	

34-56 Track Error		
Range:	Function:	
0* [-2147483647 - 2147483647]	Readout of the error between calculated command position and actual position in user unit.	

4.24 Parameters: 37-** Application Settings

4.24.1 37-0* Application Mode

37-00 Application Mode		
Option:	Function:	
[0] *	Drive mode	
[1]	Center winder	
[2]	Position Control	
[3]	Synchronization	

4.24.2 37-1* Position Control

37-01 Pos. Feedback Source		
Select position feedback source.		
Option:	Function:	
[0] *	24V Encoder	
[1]	MCB102	
[2]	MCB103	

37-02 Pos. Target		
Range:	Function:	
0* [-1073741824 - 1073741824]	If <i>parameter 37-03 Pos. Type</i> is set to [0] <i>Absolute</i> , the target position is an absolute position (relative to home position). If the <i>parameter 37-03 Pos. Type</i> is set to [1] <i>Relative</i> and the last position was obtained through jogging, the target position is relative to that position. If the last position was reached as a result of a positioning command, then the target position is relative to the last target position regardless of being reached or not.	

37-03 Pos. Type		
This parameter defines the target position type.		
Option:	Function:	
[0] *	Absolute	
[1]	Relative	

37-04 Pos. Velocity		
Range:	Function:	
100 RPM* [1 - 30000 RPM]	Defines the velocity during positioning. The maximum value must not exceed the value specified in <i>parameter 32-80 Maximum Allowed Velocity</i> .	

37-05 Pos. Ramp Up Time		
Range:	Function:	
5000 ms* [50 - 100000 ms]	It is defined as the time in milliseconds that it takes to ramp from standstill to <i>parameter 32-80 Maximum Allowed Velocity</i> .	

37-06 Pos. Ramp Down Time		
Range:	Function:	
5000 ms* [50 - 100000 ms]	It is defined as the time in milliseconds that it takes to ramp from <i>parameter 32-80 Maximum Allowed Velocity</i> to standstill.	

37-07 Pos. Auto Brake Ctrl		
When the automatic brake control function is disabled, the frequency converter controls the application also at standstill. When the automatic brake control function is enabled, the mechanical brake is automatically activated every time the application is at standstill for a time period specified in <i>parameter 37-08 Pos. Hold Delay</i> .		
Option:	Function:	
[0]	Disable	
[1] *	Enable	

37-08 Pos. Hold Delay		
Range:	Function:	
0 ms* [0 - 10000 ms]	To be used with the automatic brake control function. The hold delay is a waiting period in which the brake is not activated even though the application is at standstill.	

37-09 Pos. Coast Delay		
Range:	Function:	
200 ms* [0 - 1000 ms]	To be used with the automatic brake control function. The coast delay is the delay from activating the mechanical brake to disabling the controller and coasting the frequency converter.	

37-10 Pos. Brake Delay		
Range:	Function:	
200 ms* [0 - 1000 ms]	To be used with the automatic brake control function. The brake delay is the delay after activating the control and magnetizing the motor before opening the brake.	

37-11 Pos. Brake Wear Limit		
Range:	Function:	
0* [0 - 1073741824]	Set this parameter to a positive value. While the brake is activated, if the frequency converter moves more than the limit in user unit set in this parameter, the frequency converter reports an alarm <i>POSITION CTRL FAULT</i> with fault reason <i>Brake Wear Limit Exceeded</i> .	

37-12 Pos. PID Anti Windup

Configure whether to enable the anti-windup of positioning PID.

Option: **Function:**

[0]	Disable	
[1] *	Enable	

37-13 Pos. PID Output Clamp

Range: **Function:**

1000*	[1 - 10000]	This parameter clamps the total output of the PID. A setting of 1000 corresponds to 100% of <i>parameter 32-80 Maximum Allowed Velocity</i> .
-------	--------------	---

37-14 Pos. Ctrl. Source

Select the control source for positioning control.

Option: **Function:**

[0] *	DI	
[1]	FieldBus	

37-15 Pos. Direction Block

Use this parameter to configure whether to block a direction, and the direction to be blocked.

Option: **Function:**

[0] *	No Blocking	
[1]	Block Reverse	
[2]	Block Forward	

37-17 Pos. Ctrl Fault Behaviour

This parameter determines the behavior of the frequency converter after a fault is detected.

Option: **Function:**

[0] *	Ramp Down&Brake	
[1]	Brake Directly	

37-18 Pos. Ctrl Fault Reason

READ-ONLY PARAMETER: The current fault reason of the alarm. *POSITION CTRL FAULT* is shown in this parameter.

Option: **Function:**

[0] *	No Fault	
[1]	Homing Needed	
[2]	Pos. HW Limit	
[3]	Neg. HW Limit	
[4]	Pos. SW Limit	
[5]	Neg. SW Limit	
[7]	Brake Wear Limit	
[8]	Quick Stop	
[9]	PID Error Too Big	
[12]	Rev. Operation	
[13]	Fwd. Operation	
[20]	Can not find home position	

37-19 Pos. New Index

Range: **Function:**

0*	[0 - 255]	The currently latched index number.
----	------------	-------------------------------------

4.24.3 37-2* Center Winder

37-20 Winder Mode Selection

Use the machine for either winding or unwinding.

Option: **Function:**

[0] *	Wind	
[1]	Unwind	

37-21 Tension Set Point

Range: **Function:**

0 %*	[0 - 100 %]	Set the desired running tension. 100.0% means full tension. Full tension is the point at which the load cell or dancer produces a 20 mA or 10 V signal.
------	-------------	---

NOTICE

The taper setting affects the actual tension on the web. If a dancer system is used, this value sets the dancer running position which would normally be 500 or center of movement. This parameter is only active if *parameter 37-36 Tension Set Point Input* is set to 0.

37-22 Taper Set Point

Range: **Function:**

0 % *	[-110 - 110 %]	Change the tension setpoint as the diameter increases. The result of the taper function is called the tapered tension setpoint. The tapered tension setpoint is always equal to the tension setpoint at core. This parameter is only active if <i>parameter 37-37 Taper Set Point Input</i> is set to a value of 0. A value of 0 means no taper or the tapered tension setpoint will always be equal to the tension setpoint. A value of 100.0% is 100.0% taper or each time the diameter doubles from core the tapered tension setpoint is decreased to 50% of the previous value. Negative tapers are also possible.
-------	----------------	--

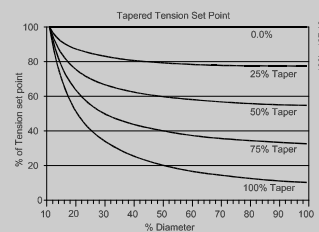

Illustration 4.31 Tapered Tension Setpoint

NOTICE

Taper is not required in unwinding applications. For unwinding applications, leave this parameter set to 0.

37-23 Partial Roll Diameter Value		
Range:	Function:	
5 %* [5 - 100 %]	Preset the diameter when a partial roll is loaded on the winder. If Input 4 is ON when the diameter is reset with Input 8, the diameter is preset to the value programmed in this parameter. For unwinding applications, use this parameter to set the full roll diameter.	

37-24 Core1 Diameter		
Range:	Function:	
5 %* [5 - 100 %]	Set the main core value to be used on the winder. This parameter must be set for the smallest core diameter for both winding and unwinding applications.	
<p>NOTICE</p> <p>The value of <i>parameter 37-24 Core1 Diameter</i> must be less than <i>parameter 37-25 Core2 Diameter</i>.</p>		

37-25 Core2 Diameter		
Range:	Function:	
5 %* [5 - 100 %]	Set a secondary core diameter for winding applications, or a secondary full roll diameter for unwinding applications.	

37-26 Winder Jog Speed		
Range:	Function:	
0 %* [0 - 100 %]	Set the winder jog speed percentage. This percentage value is used for both forward and reverse jogging speed.	

37-27 TLD Low Limit		
Range:	Function:	
0 %* [0 - 100 %]	Set the low limit for the tension limit detection.	

37-28 TLD High Limit		
Range:	Function:	
0 %* [0 - 100 %]	Set the high limit for the tension limit detection.	

37-29 TLD Timer		
Range:	Function:	
0.001 s* [0.001 - 5 s]	Set the time within which the tension must exceed the high or low tension limit.	

37-30 TLDOndelay		
Option:	Function:	
[0]	Disabled	
[1] *	Enabled	

Enable this parameter to allow time for the winder to stabilize the web tension. When the tension moves within the low and high tension limits, the TLD function begins operating normally. This function can be useful during a quick machine start with a slack web. This function is only active while running.

37-31 Diameter Limit Detector		
Range:	Function:	
100 %* [0 - 100 %]	When the calculated roll diameter reaches the set diameter, the corresponding digital output is turned on to indicate the end of the roll. This indicates a full roll when winding and an empty roll when unwinding.	

37-32 Initial Diameter Measurement		
Option:	Function:	
[0] *	Set diameter when diameter reset	Set the diameter in <i>parameter 37-23 Partial Roll Diameter Value</i> to <i>parameter 37-25 Core2 Diameter</i> when the diameter is reset.
[1]	Set diameter based on analog signal	The frequency converter sets the diameter based on an analog signal. The diameter can only be reset when the tension is OFF.

It is possible to connect a roll diameter sensor to one of the frequency converter analog inputs. This signal can be used to make the controller use a measured initial diameter, rather than a diameter size set by parameters.

37-33 Diameter Measurement Input		
Option:	Function:	
[0] *	No Function	
[1]	Input53(0~10 VDC or 0~20 mA)	
[2]	Input54(0~10 VDC or 0~20 mA)	

Set the analog input used for diameter measurement.

37-34 Reading at Core		
Range:	Function:	
0* [0 - 10]	Set the analog input signal reading at the smallest core used.	

37-35 Reading at Full Roll		
Range:	Function:	
0 V* [0 - 20 V]	Set the analog input signal reading at the full roll size used.	

37-36 Tension Set Point Input		
Set the source of the tension setpoint.		
Option:	Function:	
[0] *	Par.3721	
[1]	Input53(0~10 VDC or 0~20 mA)	
[2]	Input54(0~10 VDC or 0~20 mA)	

37-37 Taper Set Point Input		
Set the source of the taper setpoint.		
Option:	Function:	
[0] *	Par.3722	
[1]	Input53(0~10 VDC or 0~20 mA)	
[2]	Input54(0~10 VDC or 0~20 mA)	

37-38 Tension Feedback Input		
Set analog input used for tension feedback.		
Option:	Function:	
[0] *	No Function	
[1]	Input53(0~10 VDC or 0~20 mA)	
[2]	Input54(0~10 VDC or 0~20 mA)	

37-39 Tension Feedback Type		
Select the device type used for tension feedback.		
Option:	Function:	
[0] *	Load cell	
[1]	Dancer	

37-40 Center Winder Cmd Src		
Configure the command source for controlling.		
Option:	Function:	
[0]	Digital and parameter	
[1] *	Parameter 3754~3759 control the functions	
[2]	Digital input control	

37-41 Diameter Change Rate		
Range:	Function:	
0.001 %*	[0.001 - 0.05 %]	Set the number of changes allowed for the diameter in each program scan.

37-42 Tapered Tension Change Rate		
Range:	Function:	
0.1 %*	[0.1 - 1 %]	Set the amount of tapered tension that can change during each scan period. This function ramps the tapered tension setpoint to the preset value when the user changes either the tension or taper setpoints. This ensures stability during step changes in setpoints.

37-43 Diameter Calculator Min Speed		
Range:	Function:	
0 %*	[0 - 100 %]	Set the minimum line speed to be achieved before the diameter calculator is activated. At low line speeds, the resolution of the line and winder speed are too low for the diameter to be accurately calculated.

37-44 Line Acceleration Feed Forward		
Range:	Function:	
0*	[-20 - 20]	Set the feed forward speed that helps compensate for tension changes caused by line speed acceleration and deceleration.

37-45 Line Speed Source		
Use this parameter to set the input for line speed.		
Option:	Function:	
[0] *	No function	
[1]	24V encoder	
[2]	MCB102	
[3]	MCB103	
[4]	Analog input 53	
[5]	Analog input 54	
[6]	Frequency input 29	
[7]	Frequency input 33	

37-46 Winder Speed Match Scale		
Range:	Function:	
1*	[0.001 - 1000]	Match the surface speeds of line and winder at smallest core while running line at 100% speed.

37-47 Tension PID Profile		
Range:	Function:	
0 %	[0 - 100 %]	Allow scaling the tension loop PID output to compensate for roll diameter. Ideally, the output from the tension loop PID amplifier is halved each time the diameter doubles, which is considered fully profiled. Sometimes, it might be desirable to be less than fully profiled, which would give over compensation when the diameter increases.
Illustration 4.32 Tension PID Profiler		

37-48 Tension PID Proportional Gain		
Range:	Function:	
0* [0 - 10]	Set the proportional gain for tension loop PID amplifier.	

37-49 Tension PID Derivate Time		
Range:	Function:	
0 s* [0 - 20 s]	Set the derivative time for tension loop PID amplifier.	

37-50 Tension PID Integral Time		
Range:	Function:	
501 s* [0.01 - 501 s]	Set the integral time for tension loop PID amplifier.	

37-51 Tension PID Out Limit		
Range:	Function:	
0 %* [0 - 100 %]	Set the maximum tension PID loop output that can be added to the open loop speed reference. The value is normally set to limit the contribution of the tension PID loop to 10% of the maximum reference speed.	

37-52 Tension PID Der Gain Limit		
Range:	Function:	
5* [1 - 50]	Set the limit for derivation gain in tension loop PID amplifier.	

37-53 Tension PID Anti Windup		
Activate the anti-wind-up function in tension loop PID amplifier.		
Option:	Function:	
[0]	Disabled	
[1] *	Enabled	

37-54 Winder Jog Reverse		
Jog the winder in the reverse winding direction at the speed set in <i>parameter 37-26 Winder Jog Speed</i> .		
Option:	Function:	
[0] *	No Function	
[1]	Jog reverse	

37-55 Winder Jog Forward		
Jog the winder in forward winding direction at the speed set in <i>parameter 37-26 Winder Jog Speed</i> .		
Option:	Function:	
[0] *	No function	
[1]	Jog forward	

37-56 New Diameter Select		
Select partial roll diameter as the preset starting diameter when the diameter reset is energized, rather than using 1 of the 2 preset core diameters.		
Option:	Function:	
[0] *	Core diameter	
[1]	Partial roll diameter	

37-57 Tension On/Off		
Turn the tension controller on or off.		
Option:	Function:	
[0] *	Off	
[1]	On	

37-58 Core Select		
Select 1 of the 2 preset core sizes.		
Option:	Function:	
[0] *	Core1 diameter	
[1]	Core2 diameter	

37-59 Diameter Reset		
Reset the diameter to a new value. If the new diameter select is energized, the partial core diameter value is used, otherwise the diameter is reset to core 1 or core 2 values based on the selected core.		
Option:	Function:	
[0] *	Off	
[1]	On	

5 Parameter Lists

5.1 Introduction

5.1.1 Default Settings

Changes during operation

True means that the parameter can be changed while the frequency converter is in operation, and false means that the frequency converter must be stopped before a change can be made.

2-set-up

All set-ups: The parameter can be set individually in each of the 2 set-ups, that is 1 single parameter can have 2 different data values.

1 set-up: Data value is the same in all set-ups.

Data type	Description	Type
2	Integer 8	Int8
3	Integer 16	Int16
4	Integer 32	Int32
5	Unsigned 8	UInt8
6	Unsigned 16	UInt16
7	Unsigned 32	UInt32
9	Visible string	VisStr
10	Byte string	ByStr
33	Normalized value 2 bytes	N2
35	Bit sequence	BitSeq
54	Time difference w/o date	TimD

Table 5.1 Data Type

5.1.2 Conversion

The various attributes of each parameter are shown in *Factory Setting*. Parameter values are transferred as whole numbers only. Conversion factors are therefore used to transfer decimals.

Parameter 4-12 Motor Speed Low Limit [Hz] has a conversion factor of 0.1. To set the minimum frequency to 10 Hz, transfer the value 100. A conversion factor of 0.1 means that the value transferred is multiplied by 0.1. The value 100 is therefore read as 10.0.

Examples:

0 s⇒conversion index 0

0.00 s⇒conversion index -2

0 ms⇒conversion index -3

0.00 ms⇒conversion index -5

Conversion index	Conversion factor
100	1
75	3600000
74	3600
70	60
67	1/60
6	1000000
5	100000
4	10000
3	1000
2	100
1	10
0	1
-1	0.1
-2	0.01
-3	0.001
-4	0.0001
-5	0.00001
-6	0.000001
-7	0.0000001

Table 5.2 Conversion Table

5.1.3 Active/Inactive Parameters in Different Drive Control Modes

+ indicates that the parameter is active in the mode.

- indicates that the parameter is inactive in the mode.

5

Parameter 1-10 Motor Construction	AC motor	
	U/f mode	VVC ⁺
Parameter 1-01 Motor Control Principle		
Parameter 1-00 Configuration Mode		
[0] Speed Open Loop	+	+
[1] Speed Closed Loop	-	+
[2] Torque Closed Loop	-	+
[3] Process Closed Loop	+	+
[4] Torque Open Loop	-	+
[6] Surface Winder	+	+
[7] Extended PID Speed OL	+	+
Parameter 1-03 Torque Characteristics	-	+ ^{1, 2, 3)}
Parameter 1-06 Clockwise Direction	+	+
Parameter 1-20 Motor Power [kW] (parameter 0-03 Regional Settings = [0] International)	+	+
Parameter 1-22 Motor Voltage	+	+
Parameter 1-23 Motor Frequency	+	+
Parameter 1-24 Motor Current	+	+
Parameter 1-25 Motor Nominal Speed	+	+
Parameter 1-29 Automatic Motor Adaptation (AMA)	-	+
Parameter 1-30 Stator Resistance (Rs)	+	+
Parameter 1-31 Rotor Resistance (Rr)	+	+
Parameter 1-33 Stator Leakage Reactance (X1)	+	+
Parameter 1-35 Main Reactance (Xh)	+	+
Parameter 1-39 Motor Poles	+	+

Table 5.3 Active/Inactive Parameters

1) Constant torque.

2) Variable torque.

3) AEO.

Parameter 1-10 Motor Construction	AC motor	
	U/f mode	VVC ⁺
Parameter 1-01 Motor Control Principle		
Parameter 1-50 Motor Magnetisation at Zero Speed		
Parameter 1-52 Min Speed Normal Magnetising [Hz]	-	+
Parameter 1-55 U/f Characteristic - U	+	-
Parameter 1-56 U/f Characteristic - F	+	-
Parameter 1-60 Low Speed Load Compensation	-	+
Parameter 1-61 High Speed Load Compensation	-	+
Parameter 1-62 Slip Compensation	-	+ ⁴⁾
Parameter 1-63 Slip Compensation Time Constant	+ ⁵⁾	+
Parameter 1-64 Resonance Dampening	+	+
Parameter 1-65 Resonance Dampening Time Constant	+	+
Parameter 1-71 Start Delay	+	+
Parameter 1-72 Start Function	+	+
Parameter 1-73 Flying Start	-	+
Parameter 1-75 Start Speed [Hz]	-	+
Parameter 1-76 Start Current	-	+

Table 5.4 Active/Inactive Parameters

4) Not used when parameter 1-03 Torque Characteristics = VT.

5) Part of resonance damping.

Parameter 1-10 Motor Construction	AC motor	
	U/f mode	VVC ⁺
Parameter 1-01 Motor Control Principle		
Parameter 1-80 Function at Stop	+	+
Parameter 1-82 Min Speed for Function at Stop [Hz]	+	+
Parameter 1-88 AC Brake Gain	-	+
Parameter 1-90 Motor Thermal Protection	+	+
Parameter 1-93 Thermistor Resource	+	+
Parameter 2-00 DC Hold Current	+	+
Parameter 2-01 DC Brake Current	+	+
Parameter 2-02 DC Braking Time	+	+
Parameter 2-04 DC Brake Cut In Speed [Hz]	+	+
Parameter 2-10 Brake Function	+ ⁶⁾	+
Parameter 2-11 Brake Resistor (ohm)	+	+
Parameter 2-12 Brake Power Limit (kW)	+	+
Parameter 2-16 AC brake Max. Current	-	+
Parameter 2-17 Over-voltage Control	+	+
Parameter 2-19 Over-voltage Gain	+	+
Parameter 2-20 Release Brake Current	+	+
Parameter 2-22 Activate Brake Speed [Hz]	+	+

Table 5.5 Active/Inactive Parameters

6) Not AC brake.

5.2 Parameter Lists

5.2.1 0-** Operation and Display

Par. No. #	Parameter description	Default value	2-set-up	Change during operation	Conversion index	Type
0-0* Basic Settings						
0-01	Language	[0] English	1 set-up	TRUE	–	UInt8
0-03	Regional Settings	[0] International	1 set-up	FALSE	–	UInt8
0-04	Operating State at Power-up	[0] Resume	All set-ups	TRUE	–	UInt8
0-06	GridType	ExpressionLimit	1 set-up	FALSE	–	UInt8
0-07	Auto DC Braking	[1] On	1 set-up	FALSE	–	UInt8
0-1* Set-up Operations						
0-10	Active Set-up	[1] Set-up 1	1 set-up	TRUE	–	UInt8
0-11	Programming Set-up	[9] Active Set-up	1 set-up	TRUE	–	UInt8
0-12	Link Setups	[20] Linked	All set-ups	FALSE	–	UInt8
0-14	Readout: Edit Set-ups/Channel	0 N/A	All set-ups	TRUE	0	Int32
0-16	Application Selection	[0] None	All set-ups	FALSE	–	UInt8
0-2* LCP Display						
0-20	Display Line 1.1 Small	1602	All set-ups	TRUE	–	UInt16
0-21	Display Line 1.2 Small	1614	All set-ups	TRUE	–	UInt16
0-22	Display Line 1.3 Small	1610	All set-ups	TRUE	–	UInt16
0-23	Display Line 2 Large	1613	All set-ups	TRUE	–	UInt16
0-24	Display Line 3 Large	1502	All set-ups	TRUE	–	UInt16
0-3* LCP Custom Readout						
0-30	Custom Readout Unit	[1] %	1 set-up	TRUE	–	UInt8
0-31	Custom Readout Min Value	0 CustomReadoutUnit	1 set-up	TRUE	-2	Int32
0-32	Custom Readout Max Value	100 CustomReadoutUnit	1 set-up	TRUE	-2	Int32
0-37	Display Text 1	□	1 set-up	TRUE	0	VisStr[21]
0-38	Display Text 2	□	1 set-up	TRUE	0	VisStr[26]
0-39	Display Text 3	□	1 set-up	TRUE	0	VisStr[26]
0-4* LCP Keypad						
0-40	[Hand on] Key on LCP	[1] Enabled	All set-ups	TRUE	–	UInt8
0-42	[Auto on] Key on LCP	[1] Enabled	All set-ups	TRUE	–	UInt8
0-44	[Off/Reset] Key on LCP	[1] Enabled	All set-ups	TRUE	–	UInt8
0-5* Copy/Save						
0-50	LCP Copy	[0] No copy	1 set-up	FALSE	–	UInt8
0-51	Set-up Copy	[0] No copy	1 set-up	FALSE	–	UInt8
0-6* Password						
0-60	Main Menu Password	0 N/A	1 set-up	TRUE	0	UInt16

5.2.2 1-** Load and Motor

Par. No. #	Parameter description	Default value	2-set-up	Change during operation	Conversion index	Type
1-0* General Settings						
1-00	Configuration Mode	[0] Open Loop	All set-ups	TRUE	-	UInt8
1-01	Motor Control Principle	[1] VVC+	All set-ups	FALSE	-	UInt8
1-03	Torque Characteristics	[0] Constant torque	All set-ups	FALSE	-	UInt8
1-06	Clockwise Direction	[0] Normal	1 set-up	FALSE	-	UInt8
1-08	Motor Control Bandwidth	ExpressionLimit	All set-ups	FALSE	-	UInt8
1-1* Motor Selection						
1-10	Motor Construction	[0] Asynchron	All set-ups	FALSE	-	UInt8
1-14	Damping Gain	120%	All set-ups	TRUE	0	Int16
1-15	Low Speed Filter Time Const.	ExpressionLimit	All set-ups	TRUE	-2	UInt16
1-16	High Speed Filter Time Const.	ExpressionLimit	All set-ups	TRUE	-2	UInt16
1-17	Voltage filter time const.	ExpressionLimit	All set-ups	TRUE	-3	UInt16
1-2* Motor Data						
1-20	Motor Power	ExpressionLimit	All set-ups	FALSE	-	UInt8
1-22	Motor Voltage	ExpressionLimit	All set-ups	FALSE	0	UInt16
1-23	Motor Frequency	ExpressionLimit	All set-ups	FALSE	0	UInt16
1-24	Motor Current	ExpressionLimit	All set-ups	FALSE	-2	UInt32
1-25	Motor Nominal Speed	ExpressionLimit	All set-ups	FALSE	67	UInt16
1-26	Motor Cont. Rated Torque	ExpressionLimit	All set-ups	FALSE	-1	UInt32
1-29	Automatic Motor Adaption (AMA)	[0] Off	All set-ups	FALSE	-	UInt8
1-3* Adv. Motor Data I						
1-30	Stator Resistance (Rs)	ExpressionLimit	All set-ups	FALSE	-3	UInt32
1-31	Rotor Resistance (Rr)	ExpressionLimit	All set-ups	FALSE	-3	UInt32
1-33	Stator Leakage Reactance (X1)	ExpressionLimit	All set-ups	FALSE	-3	UInt32
1-35	Main Reactance (Xh)	ExpressionLimit	All set-ups	FALSE	-2	UInt32
1-37	d-axis Inductance (Ld)	ExpressionLimit	All set-ups	FALSE	-3	Int32
1-38	q-axis Inductance (Lq)	ExpressionLimit	All set-ups	FALSE	-6	Int32
1-39	Motor Poles	ExpressionLimit	All set-ups	FALSE	0	UInt8
1-4* Adv. Motor Data II						
1-40	Back EMF at 1000 RPM	ExpressionLimit	All set-ups	FALSE	0	UInt16
1-42	Motor Cable Length	50 m	All set-ups	FALSE	0	UInt8
1-43	Motor Cable Length Feet	164 ft	All set-ups	FALSE	0	UInt16
1-44	d-axis Inductance Sat. (LdSat)	ExpressionLimit	All set-ups	FALSE	-3	Int32
1-45	q-axis Inductance Sat. (LqSat)	ExpressionLimit	All set-ups	FALSE	-3	Int32
1-46	Position Detection Gain	100%	All set-ups	TRUE	0	UInt16
1-48	Current at Min Inductance for d-axis	100%	All set-ups	TRUE	0	UInt16
1-49	Current at Min Inductance for q-axis	100%	All set-ups	TRUE	0	UInt16
1-5* Load Indep. Setting						
1-50	Motor Magnetisation at Zero Speed	100%	All set-ups	TRUE	0	UInt16
1-52	Min Speed Normal Magnetising [Hz]	1 Hz	All set-ups	TRUE	-1	UInt16
1-55	U/f Characteristic - U	ExpressionLimit	All set-ups	FALSE	-1	UInt16
1-56	U/f Characteristic - F	ExpressionLimit	All set-ups	FALSE	-1	UInt16
1-6* Load Depen. Setting						
1-60	Low Speed Load Compensation	100%	All set-ups	TRUE	0	Int16
1-61	High Speed Load Compensation	100%	All set-ups	TRUE	0	Int16
1-62	Slip Compensation	ExpressionLimit	All set-ups	TRUE	0	Int16
1-63	Slip Compensation Time Constant	0.1 s	All set-ups	TRUE	-2	UInt16
1-64	Resonance Dampening	100%	All set-ups	TRUE	0	UInt16
1-65	Resonance Dampening Time Constant	0.005 s	All set-ups	TRUE	-3	UInt16

Par. No. #	Parameter description	Default value	2-set-up	Change during operation	Conversion index	Type
1-66	Min. Current at Low Speed	50%	All set-ups	TRUE	0	Uint32
1-7* Start Adjustments						
1-70	PM Start Mode	[0] Rotor Detection	All set-ups	TRUE	-	Uint8
1-71	Start Delay	0 s	All set-ups	TRUE	-1	Uint8
1-72	Start Function	[2] Coast/delay time	All set-ups	TRUE	-	Uint8
1-73	Flying Start	ExpressionLimit	All set-ups	TRUE	-	Uint8
1-75	Start Speed [Hz]	ExpressionLimit	All set-ups	TRUE	-1	Uint16
1-76	Start Current	ExpressionLimit	All set-ups	TRUE	-2	Uint32
1-78	Compressor Start Max Speed [Hz]	0 Hz	All set-ups	TRUE	-1	Uint16
1-79	Compressor Start Max Time to Trip	5 s	All set-ups	TRUE	-1	Uint8
1-8* Stop Adjustments						
1-80	Function at Stop	[0] Coast	All set-ups	TRUE	-	Uint8
1-82	Min Speed for Function at Stop [Hz]	0 Hz	All set-ups	TRUE	-1	Uint16
1-9* Motor Temperature						
1-90	Motor Thermal Protection	[0] No protection	All set-ups	TRUE	-	Uint8
1-93	Thermistor Source	[0] None	All set-ups	FALSE	-	Uint8

5.2.3 2-** Brakes

Par. No. #	Parameter description	Default value	2-set-up	Change during operation	Conversion index	Type
2-0* DC-Brake						
2-00	DC Hold/Motor Preheat Current	50%	All set-ups	TRUE	0	Uint16
2-01	DC Brake Current	50%	All set-ups	TRUE	0	Uint16
2-02	DC Braking Time	10 s	All set-ups	TRUE	-1	Uint16
2-04	DC Brake Cut In Speed	0 Hz	All set-ups	TRUE	-1	Uint16
2-06	Parking Current	100%	All set-ups	TRUE	0	Uint16
2-07	Parking Time	3 s	All set-ups	TRUE	-1	Uint16
2-1* Brake Energy Funct.						
2-10	Brake Function	[0] Off	All set-ups	FALSE	-	Uint8
2-11	Brake Resistor (ohm)	ExpressionLimit	All set-ups	FALSE	-1	Uint16
2-12	Brake Power Limit (kW)	ExpressionLimit	All set-ups	TRUE	0	Uint32
2-14	Brake voltage reduce	0 V	All set-ups	FALSE	0	Uint16
2-16	AC Brake, Max current	100%	All set-ups	TRUE	-1	Uint16
2-17	Over-voltage Control	[0] Disabled	All set-ups	TRUE	-	Uint8
2-19	Over-voltage Gain	100%	All set-ups	TRUE	0	Uint16
2-2* Mechanical Brake						
2-20	Release Brake Current	0 A	All set-ups	TRUE	-2	Uint32
2-22	Activate Brake Speed [Hz]	0 Hz	All set-ups	TRUE	-1	Uint16
2-23	Activate Brake Delay	0.0 s	All set-ups	TRUE	-1	Uint8

5.2.4 3-** Reference/Ramps

Par. No. #	Parameter description	Default value	2-set-up	Change during operation	Conversion index	Type
3-0* Reference Limits						
3-00	Reference Range	[0] Min - Max	All set-ups	TRUE	-	Uint8
3-01	Reference/Feedback Unit	ExpressionLimit	All set-ups	TRUE	-	Uint8
3-02	Minimum Reference	0 ReferenceFeedbackUnit	All set-ups	TRUE	-3	Int32
3-03	Maximum Reference	ExpressionLimit	All set-ups	TRUE	-3	Int32
3-04	Reference Function	[0] Sum	All set-ups	TRUE	-	Uint8
3-1* References						
3-10	Preset Reference	0%	All set-ups	TRUE	-2	Int16
3-11	Jog Speed [Hz]	5 Hz	All set-ups	TRUE	-1	Uint16
3-12	Catch up/slow Down Value	0%	All set-ups	TRUE	-2	Int16
3-14	Preset Relative Reference	0%	All set-ups	TRUE	-2	Int16
3-15	Reference 1 Source	[1] Analog Input 53	All set-ups	TRUE	-	Uint8
3-16	Reference 2 Source	[2] Analog Input 54	All set-ups	TRUE	-	Uint8
3-17	Reference 3 Source	[11] Local bus reference	All set-ups	TRUE	-	Uint8
3-18	Relative Scaling Reference Resource	[0] No function	All set-ups	TRUE	--	Uint8
3-4* Ramp 1						
3-40	Ramp 1 Type	[0] Linear	All set-ups	TRUE	-	Uint8
3-41	Ramp 1 Ramp Up Time	ExpressionLimit	All set-ups	TRUE	-2	Uint32
3-42	Ramp 1 Ramp Down Time	ExpressionLimit	All set-ups	TRUE	-2	Uint32
3-5* Ramp 2						
3-50	Ramp 2 Type	[0] Linear	All set-ups	TRUE	-	Uint8
3-51	Ramp 2 Ramp Up Time	ExpressionLimit	All set-ups	TRUE	-2	Uint32
3-52	Ramp 2 Ramp Down Time	ExpressionLimit	All set-ups	TRUE	-2	Uint32
3-6* Ramp 3						
3-60	Ramp 3 Type	[0] Linear	All set-ups	TRUE	-	Uint8
3-61	Ramp 3 Ramp up Time	ExpressionLimit	All set-ups	TRUE	-2	Uint32
3-62	Ramp 3 Ramp down Time	ExpressionLimit	All set-ups	TRUE	-2	Uint32
3-7* Ramp 4						
3-70	Ramp 4 Type	[0] Linear	All set-ups	TRUE	-	Uint8
3-71	Ramp 4 Ramp up Time	ExpressionLimit	All set-ups	TRUE	-2	Uint32
3-72	Ramp 4 Ramp Down Time	ExpressionLimit	All set-ups	TRUE	-2	Uint32
3-8* Other Ramps						
3-80	Jog Ramp Time	ExpressionLimit	All set-ups	TRUE	-2	Uint32
3-81	Quick Stop Ramp Time	ExpressionLimit	1 set-up	TRUE	-2	Uint32
3-9* Digital Pot.Meter						
3-90	Step Size	0.10%	All set-ups	TRUE	-2	Uint16
3-92	Power Restore	[0] Off	All set-ups	TRUE	-	Uint8
3-93	Maximum Limit	100%	All set-ups	TRUE	0	Int16
3-94	Minimum Limit	-100%	All set-ups	TRUE	0	Int16
3-95	Ramp Delay	1000 ms	All set-ups	TRUE	-3	Uint16

5.2.5 4-** Limits/Warnings

Par. No. #	Parameter description	Default value	2-set-up	Change during operation	Conversion index	Type
4-1* Motor Limits						
4-10	Motor Speed Direction	[2] Both directions	All set-ups	FALSE	-	Uint8
4-12	Motor Speed Low Limit [Hz]	0 Hz	All set-ups	FALSE	-1	Uint16
4-14	Motor Speed High Limit [Hz]	65 Hz	All set-ups	FALSE	-1	Uint16
4-16	Torque Limit Motor Mode	ExpressionLimit	All set-ups	TRUE	0	Uint16
4-17	Torque Limit Generator Mode	100%	All set-ups	TRUE	0	Uint16
4-18	Current Limit	ExpressionLimit	All set-ups	TRUE	0	Uint16
4-19	Max Output Frequency	ExpressionLimit	All set-ups	FALSE	-1	Uint16
4-2* Limit Factors						
4-20	Torque Limit Factor Source	[0] No function	All set-ups	TRUE	-	Uint8
4-21	Speed Limit Factor Source	[0] No function	All set-ups	TRUE	-	Uint8
4-22	Break Away Boost	[0] Off	All set-ups	FALSE	-	Uint8
4-3* Motor Fb Monitor						
4-30	Motor Feedback Loss Function	[0] Disabled	All set-ups	TRUE	-	Uint8
4-31	Motor Feedback Speed Error	20 Hz	All set-ups	TRUE	0	Uint16
4-32	Motor Feedback Loss Timeout	0.05 s	All set-ups	TRUE	-2	Uint16
4-4* Adj. Warnings 2						
4-40	Warning Freq. Low	ExpressionLimit	All set-ups	TRUE	-1	Uint16
4-41	Warning Freq. High	ExpressionLimit	All set-ups	TRUE	-1	Uint16
4-42	Adjustable Temperature Warning	0 N/A	All set-ups	TRUE	0	Uint8
4-5* Adj. Warnings						
4-50	Warning Current Low	0 A	All set-ups	TRUE	-2	Uint32
4-51	Warning Current High	ExpressionLimit	All set-ups	TRUE	-2	Uint32
4-54	Warning Reference Low	-4999 N/A	All set-ups	TRUE	-3	Int32
4-55	Warning Reference High	4999 N/A	All set-ups	TRUE	-3	Int32
4-56	Warning Feedback Low	-4999 ProcessCtrlUnit	All set-ups	TRUE	-3	Int32
4-57	Warning Feedback High	4999 ProcessCtrlUnit	All set-ups	TRUE	-3	Int32
4-58	Missing Motor Phase Function	[1] On	All set-ups	FALSE	-	Uint8
4-6* Speed Bypass						
4-61	Bypass Speed From [Hz]	0 Hz	All set-ups	TRUE	-1	Uint16
4-63	Bypass Speed To [Hz]	0 Hz	All set-ups	TRUE	-1	Uint16

5.2.6 5-** Digital In/Out

Par. No. #	Parameter description	Default value	2-set-up	Change during operation	Conversion index	Type
5-0* Digital I/O mode						
5-00	Digital I/O Mode	[0] PNP	1 set-up	FALSE	-	UInt8
5-01	Terminal 27 Mode	[0] Input	All set-ups	TRUE	-	UInt8
5-02	Terminal 29 Mode	[0] Input	All set-ups	TRUE	-	UInt8
5-1* Digital Inputs						
5-10	Terminal 18 Digital Input	[8] Start	All set-ups	TRUE	-	UInt8
5-11	Terminal 19 Digital Input	[10] Reversing	All set-ups	TRUE	-	UInt8
5-12	Terminal 27 Digital Input	ExpressionLimit	All set-ups	TRUE	-	UInt8
5-13	Terminal 29 Digital Input	[14] Jog	All set-ups	TRUE	-	UInt8
5-14	Terminal 32 Digital Input	[0] No operation	All set-ups	TRUE	-	UInt8
5-15	Terminal 33 Digital Input	[16] Preset ref bit 0	All set-ups	TRUE	-	UInt8
5-16	Terminal 31 Digital Input	[0] No operation	All set-ups	TRUE	-	UInt8
5-3* Digital Outputs						
5-30	Terminal 27 Digital Output	[0] No operation	All set-ups	TRUE	-	UInt8
5-31	Terminal 29 Digital Output	[0] No operation	All set-ups	TRUE	-	UInt8
5-34	On Delay, Digital Output	0.01 s	All set-ups	TRUE	-2	UInt16
5-35	Off Delay, Digital Output	0.01 s	All set-ups	TRUE	-2	UInt16
5-4* Relays						
5-40	Function Relay	ExpressionLimit	All set-ups	TRUE	-	UInt8
5-41	On Delay, Relay	0.01 s	All set-ups	TRUE	-2	UInt16
5-42	Off Delay, Relay	0.01 s	All set-ups	TRUE	-2	UInt16
5-5* Pulse Input						
5-50	Term. 29 Low Frequency	4 Hz	All set-ups	TRUE	0	UInt32
5-51	Term. 29 High Frequency	32000 Hz	All set-ups	TRUE	0	UInt32
5-52	Term. 29 Low Ref./Feedb. Value	0 N/A	All set-ups	TRUE	-3	Int32
5-53	Term. 29 High Ref./Feedb. Value	ExpressionLimit	All set-ups	TRUE	-3	Int32
5-55	Term. 33 Low Frequency	4 Hz	All set-ups	TRUE	0	UInt32
5-56	Term. 33 High Frequency	32000 Hz	All set-ups	TRUE	0	UInt32
5-57	Term. 33 Low Ref./Feedb. Value	0 N/A	All set-ups	TRUE	-3	Int32
5-58	Term. 33 High Ref./Feedb. Value	ExpressionLimit	All set-ups	TRUE	-3	Int32
5-6* Pulse Output						
5-60	Terminal 27 Pulse Output Variable	[0] No operation	All set-ups	TRUE	-	UInt8
5-62	Pulse Output Max Freq 27	5000 Hz	All set-ups	TRUE	0	UInt32
5-63	Terminal 29 Pulse Output Variable	[0] No operation	All set-ups	TRUE	-	UInt8
5-65	Pulse Output Max Freq 29	5000 Hz	All set-ups	TRUE	0	UInt32
5-7* 24 V Encoder Input						
5-70	Term 32/33 Pulses Per Revolution	1024 N/A	All set-ups	FALSE	0	UInt16
5-71	Term 32/33 Encoder Direction	[0] Clockwise	All set-ups	FALSE	-	UInt8
5-9* Bus Controlled						
5-90	Digital & Relay Bus Control	0 N/A	All set-ups	TRUE	0	UInt32
5-93	Pulse Out 27 Bus Control	0%	All set-ups	TRUE	-2	UInt16
5-94	Pulse Out 27 Timeout Preset	0%	1 set-up	TRUE	-2	UInt16
5-95	Pulse Out 29 Bus Control	0%	All set-ups	TRUE	-2	UInt16
5-96	Pulse Out 29 Timeout Preset	0%	1 set-up	TRUE	-2	UInt16

5.2.7 6-** Analog In/Out

Par. No. #	Parameter description	Default value	2-set-up	Change during operation	Conversion index	Type
6-0* Analog I/O Mode						
6-00	Live Zero Timeout Time	10 s	All set-ups	TRUE	0	Uint8
6-01	Live Zero Timeout Function	[0] Off	All set-ups	TRUE	-	Uint8
6-1* Analog Input 53						
6-10	Terminal 53 Low Voltage	0.07 V	All set-ups	TRUE	-2	Uint16
6-11	Terminal 53 High Voltage	10 V	All set-ups	TRUE	-2	Uint16
6-12	Terminal 53 Low Current	4 mA	All set-ups	TRUE	-5	Uint16
6-13	Terminal 53 High Current	20 mA	All set-ups	TRUE	-5	Uint16
6-14	Terminal 53 Low Ref./Feedb. Value	0 N/A	All set-ups	TRUE	-3	Int32
6-15	Terminal 53 High Ref./Feedb. Value	ExpressionLimit	All set-ups	TRUE	-3	Int32
6-16	Terminal 53 Filter Time Constant	0.01 s	All set-ups	TRUE	-2	Uint16
6-19	Terminal 53 mode	[1] Voltage mode	1 set-up	TRUE	-	Uint8
6-2* Analog Input 54						
6-20	Terminal 54 Low Voltage	0.07 V	All set-ups	TRUE	-2	Uint16
6-21	Terminal 54 High Voltage	10 V	All set-ups	TRUE	-2	Uint16
6-22	Terminal 54 Low Current	4 mA	All set-ups	TRUE	-5	Uint16
6-23	Terminal 54 High Current	20 mA	All set-ups	TRUE	-5	Uint16
6-24	Terminal 54 Low Ref./Feedb. Value	0 N/A	All set-ups	TRUE	-3	Int32
6-25	Terminal 54 High Ref./Feedb. Value	ExpressionLimit	All set-ups	TRUE	-3	Int32
6-26	Terminal 54 Filter Time Constant	0.01 s	All set-ups	TRUE	-2	Uint16
6-29	Terminal 54 mode	[1] Voltage mode	1 set-up	TRUE	-	Uint8
6-7* Analog/Digital Output 45						
6-70	Terminal 45 Mode	[0] 0-20 mA	All set-ups	TRUE	-	Uint8
6-71	Terminal 45 Analog Output	[0] No operation	All set-ups	TRUE	-	Uint8
6-72	Terminal 45 Digital Output	[0] No operation	All set-ups	TRUE	-	Uint8
6-73	Terminal 45 Output Min Scale	0%	All set-ups	TRUE	-2	Uint16
6-74	Terminal 45 Output Max Scale	100%	All set-ups	TRUE	-2	Uint16
6-76	Terminal 45 Output Bus Control	0 N/A	All set-ups	TRUE	0	Uint16
6-9* Analog/Digital Output 42						
6-90	Terminal 42 Mode	[0] 0-20 mA	All set-ups	TRUE	-	Uint8
6-91	Terminal 42 Analog Output	[0] No operation	All set-ups	TRUE	-	Uint8
6-92	Terminal 42 Digital Output	[0] No operation	All set-ups	TRUE	-	Uint8
6-93	Terminal 42 Output Min Scale	0%	All set-ups	TRUE	-2	Uint16
6-94	Terminal 42 Output Max Scale	100%	All set-ups	TRUE	-2	Uint16
6-96	Terminal 42 Output Bus Control	0 N/A	All set-ups	TRUE	0	Uint16

5.2.8 7-** Controllers

Par. No. #	Parameter description	Default value	2-set-up	Change during operation	Conversion index	Type
7-0* Speed PID Ctrl.						
7-00	Speed PID Feedback Source	[20] None	All set-ups	FALSE	-	Uint8
7-02	Speed PID Proportional Gain	0.015 N/A	All set-ups	TRUE	-3	Uint16
7-03	Speed PID Integral Time	8 ms	All set-ups	TRUE	-4	Uint32
7-04	Speed PID Differentiation Time	30 ms	All set-ups	TRUE	-4	Uint16
7-05	Speed PID Diff. Gain Limit	5 N/A	All set-ups	TRUE	-1	Uint16
7-06	Speed PID Lowpass Filter Time	10 ms	All set-ups	TRUE	-4	Uint16
7-07	Speed PID Feedback Gear Ratio	1 N/A	All set-ups	FALSE	-4	Uint32
7-08	Speed PID Feed Forward Factor	0%	All set-ups	FALSE	0	Uint16
7-1* Torque PID Ctrl.						
7-12	Torque PID Proportional Gain	100%	All set-ups	TRUE	0	Uint16
7-13	Torque PID Integration Time	0.020 s	All set-ups	TRUE	-3	Uint16
7-2* Process Ctrl. Feedb						
7-20	Process CL Feedback 1 Resource	[0] No function	All set-ups	TRUE	-	Uint8
7-22	Process CL Feedback 2 Resource	[0] No function	All set-ups	TRUE	-	Uint8
7-3* Process PID Ctrl.						
7-30	Process PID Normal/ Inverse Control	[0] Normal	All set-ups	TRUE	-	Uint8
7-31	Process PID Anti Windup	[1] On	All set-ups	TRUE	-	Uint8
7-32	Process PID Start Speed	0 RPM	All set-ups	TRUE	67	Uint16
7-33	Process PID Proportional Gain	0.01 N/A	All set-ups	TRUE	-2	Uint16
7-34	Process PID Integral Time	9999 s	All set-ups	TRUE	-2	Uint32
7-35	Process PID Differentiation Time	0 s	All set-ups	TRUE	-2	Uint16
7-36	Process PID Diff. Gain Limit	5 N/A	All set-ups	TRUE	-1	Uint16
7-38	Process PID Feed Forward Factor	0%	All set-ups	TRUE	0	Uint16
7-39	On Reference Bandwidth	5%	All set-ups	TRUE	0	Uint8
7-4* Adv. Process PID I						
7-40	Process PID I-part Reset	[0] No	All set-ups	TRUE	-	Uint8
7-41	Process PID Output Neg. Clamp	-100 %	All set-ups	TRUE	0	Int16
7-42	Process PID Output Pos. Clamp	100%	All set-ups	TRUE	0	Int16
7-43	Process PID Gain Scale at Min. Ref.	100%	All set-ups	TRUE	0	Int16
7-44	Process PID Gain Scale at Max. Ref.	100%	All set-ups	TRUE	0	Int16
7-45	Process PID Feed Fwd Resource	[0] No function	All set-ups	TRUE	-	Uint8
7-46	Process PID Feed Fwd Normal/ Inv. Ctrl.	[0] Normal	All set-ups	TRUE	-	Uint8
7-48	PCD Feed Forward	0 N/A	All set-ups	TRUE	0	Uint16
7-49	Process PID Output Normal/ Inv. Ctrl.	[0] Normal	All set-ups	TRUE	-	Uint8
7-5* Adv. Process PID II						
7-50	Process PID Extended PID	[1] Enabled	All set-ups	TRUE	-	Uint8
7-51	Process PID Feed Fwd Gain	1 N/A	All set-ups	TRUE	-2	Uint16
7-52	Process PID Feed Fwd Ramp up	0.01 s	All set-ups	TRUE	-2	Uint32
7-53	Process PID Feed Fwd Ramp down	0.01 s	All set-ups	TRUE	-2	Uint32
7-56	Process PID Ref. Filter Time	0.001 s	All set-ups	TRUE	-3	Uint16
7-57	Process PID Fb. Filter Time	0.001 s	All set-ups	TRUE	-3	Uint16
7-6* Feedback Conversion						
7-60	Feedback 1 Conversion	[0] Linear	All set-ups	TRUE	-	Uint8
7-62	Feedback 2 Conversion	[0] Linear	All set-ups	TRUE	-	Uint8

5.2.9 8-** Communications and Options

Par. No. #	Parameter description	Default value	2-set-up	Change during operation	Conversion index	Type
8-0* General Settings						
8-01	Control Site	[0] Digital and ctrl.word	All set-ups	TRUE	-	Uint8
8-02	Control Source	ExpressionLimit	All set-ups	TRUE	-	Uint8
8-03	Control Timeout Time	1 s	1 set-up	TRUE	-1	Uint16
8-04	Control Timeout Function	[0] Off	1 set-up	TRUE	-	Uint8
8-07	Diagnosis Trigger	[0] Disable	1 set-up	TRUE	-	Uint8
8-1* Ctrl. Word Settings						
8-10	Control Word Profile	[0] FC profile	All set-ups	TRUE	-	Uint8
8-14	Configurable Control Word CTW	[1] Profile default	All set-ups	TRUE	-	Uint8
8-19	Product Code	ExpressionLimit	1 set-up	TRUE	0	Uint32
8-3* FC Port Settings						
8-30	Protocol	[0] FC	1 set-up	TRUE	-	Uint8
8-31	Address	1 N/A	1 set-up	TRUE	0	Uint8
8-32	Baud Rate	ExpressionLimit	1 set-up	TRUE	-	Uint8
8-33	Parity/Stop Bits	ExpressionLimit	1 set-up	TRUE	-	Uint8
8-35	Minimum Response Delay	0.01 s	1 set-up	TRUE	-3	Uint16
8-36	Maximum Response Delay	ExpressionLimit	1 set-up	TRUE	-3	Uint16
8-37	Maximum Inter-char delay	0.025 s	1 set-up	TRUE	-3	Uint16
8-4* FC MC protocol set						
8-42	PCD Write Configuration	ExpressionLimit	All set-ups	TRUE	-	Uint8
8-43	PCD Read Configuration	ExpressionLimit	1 set-up	TRUE	-	Uint8
8-5* Digital/Bus						
8-50	Coasting Select	[3] Logic OR	All set-ups	TRUE	-	Uint8
8-51	Quick Stop Select	[3] Logic OR	All set-ups	TRUE	-	Uint8
8-52	DC Brake Select	[3] Logic OR	All set-ups	TRUE	-	Uint8
8-53	Start Select	[3] Logic OR	All set-ups	TRUE	-	Uint8
8-54	Reversing Select	[3] Logic OR	All set-ups	TRUE	-	Uint8
8-55	Set-up Select	[3] Logic OR	All set-ups	TRUE	-	Uint8
8-56	Preset Reference Select	[3] Logic OR	All set-ups	TRUE	-	Uint8
8-57	PROFIdrive OFF2 Select	[3] Logic OR	All set-ups	TRUE	-	Uint8
8-58	PROFIdrive OFF3 Select	[3] Logic OR	All set-ups	TRUE	-	Uint8
8-7* Protocol Firmware Version						
8-79	Protocol Firmware version	ExpressionLimit	1 set-up	FALSE	-2	Uint16
8-8* FC Port Diagnostics						
8-80	Bus Message Count	0 N/A	1 set-up	TRUE	0	Uint32
8-81	Bus Error Count	0 N/A	1 set-up	TRUE	0	Uint32
8-82	Slave Messages Rcvd	0 N/A	1 set-up	TRUE	0	Uint32
8-83	Slave Error Count	0 N/A	1 set-up	TRUE	0	Uint32
8-84	Slave Messages Sent	0 N/A	1 set-up	TRUE	0	Uint32
8-85	Slave Timeout Errors	0 N/A	1 set-up	TRUE	0	Uint32
8-88	Reset FC port Diagnostics	[0] Do not reset	1 set-up	TRUE	-	Uint8
8-9* Bus Feedback						
8-90	Bus Jog 1 Speed	100 RPM	All set-ups	TRUE	67	Uint16
8-91	Bus Jog 2 Speed	200 RPM	All set-ups	TRUE	67	Uint16

5.2.10 9-** PROFIdrive

Par. No. #	Parameter description	Default value	2-set-up	Change during operation	Conversion index	Type
9-00	Setpoint	0 N/A	All set-ups	TRUE	0	Uint16
9-07	Actual Value	0 N/A	All set-ups	FALSE	0	Uint16
9-15	PCD Write Configuration	ExpressionLimit	1 set-up	TRUE	-	Uint16
9-16	PCD Read Configuration	ExpressionLimit	1 set-up	TRUE	-	Uint16
9-18	Node Address	126 N/A	1 set-up	TRUE	0	Uint8
9-19	Drive Unit System Number	1037 N/A	All set-ups	TRUE	0	Uint16
9-22	Telegram Selection	[100] None	1 set-up	TRUE	-	Uint8
9-23	Parameters for Signals	0	All set-ups	TRUE	-	Uint16
9-27	Parameter Edit	[1] Enabled	1 set-up	FALSE	-	Uint16
9-28	Process Control	[1] Enable cyclic master	1 set-up	FALSE	-	Uint8
9-44	Fault Message Counter	0 N/A	All set-ups	TRUE	0	Uint16
9-45	Fault Code	0 N/A	All set-ups	TRUE	0	Uint16
9-47	Fault Number	0 N/A	All set-ups	TRUE	0	Uint16
9-52	Fault Situation Counter	0 N/A	All set-ups	TRUE	0	Uint16
9-53	PROFIBUS Warning Word	0 N/A	All set-ups	TRUE	0	V2
9-63	Actual Baud Rate	[255] No baudrate found	All set-ups	TRUE	-	Uint8
9-64	Device Identification	0 N/A	All set-ups	TRUE	0	Uint16
9-65	Profile Number	0 N/A	All set-ups	TRUE	0	OctStr[0]
9-67	Control Word 1	0 N/A	All set-ups	TRUE	0	V2
9-68	Status Word 1	0 N/A	All set-ups	TRUE	0	V2
9-70	Programming Set-up	[9] Active Set-up	1 set-up	TRUE	-	Uint8
9-71	PROFIBUS Save Data Values	[0] Off	All set-ups	TRUE	-	Uint8
9-72	PROFIBUSDriveReset	[0] No action	1 set-up	FALSE	-	Uint8
9-75	DO Identification	0 N/A	All set-ups	TRUE	0	Uint16
9-80	Defined Parameters (1)	0 N/A	All set-ups	FALSE	0	Uint16
9-81	Defined Parameters (2)	0 N/A	All set-ups	FALSE	0	Uint16
9-82	Defined Parameters (3)	0 N/A	All set-ups	FALSE	0	Uint16
9-83	Defined Parameters (4)	0 N/A	All set-ups	FALSE	0	Uint16
9-84	Defined Parameters (5)	0 N/A	All set-ups	FALSE	0	Uint16
9-90	Changed Parameters (1)	0 N/A	All set-ups	FALSE	0	Uint16
9-91	Changed Parameters (2)	0 N/A	All set-ups	FALSE	0	Uint16
9-92	Changed Parameters (3)	0 N/A	All set-ups	FALSE	0	Uint16
9-93	Changed Parameters (4)	0 N/A	All set-ups	FALSE	0	Uint16
9-94	Changed Parameters (5)	0 N/A	All set-ups	FALSE	0	Uint16
9-99	PROFIBUS Revision Counter	0 N/A	All set-ups	TRUE	0	Uint16

5.2.11 12-** Ethernet

Par. No. #	Parameter description	Default value	2-set-up	Change during operation	Conversion index	Type
12-0* IP Settings						
12-00	IP Address Assignment	[10] DCP	1 set-up	TRUE	–	Uint8
12-01	IP Address	0 N/A	1 set-up	TRUE	0	OctStr[4]
12-02	Subnet Mask	0 N/A	1 set-up	TRUE	0	OctStr[4]
12-03	Default Gateway	0 N/A	1 set-up	TRUE	0	OctStr[4]
12-04	DHCP Server	0 N/A	1 set-up	TRUE	0	OctStr[4]
12-05	Lease Expires	0 N/A	All set-ups	TRUE	0	TimD
12-06	Name Servers	0 N/A	1 set-up	TRUE	0	OctStr[4]
12-07	Domain Name	0 N/A	1 set-up	TRUE	0	VisStr[48]
12-08	Host Name	0 N/A	1 set-up	TRUE	0	VisStr[48]
12-09	Physical Address	0 N/A	1 set-up	TRUE	0	VisStr[17]
12-1* Ethernet Link Parameters						
12-10	Link Status	[0] No Link	1 set-up	TRUE	–	Uint8
12-11	Link Duration	ExpressionLimit	All set-ups	TRUE	0	TimD
12-12	Auto Negotiation	[1] On	1 set-up	TRUE	–	Uint8
12-13	Link Speed	[0] None	1 set-up	TRUE	–	Uint8
12-14	Link Duplex	[1] Full Duplex	1 set-up	TRUE	–	Uint8
12-8* Other Ethernet Services						
12-80	FTP Server	[0] Disabled	1 set-up	TRUE	–	Uint8
12-81	HTTP Server	[0] Disabled	1 set-up	TRUE	–	Uint8
12-82	SMTP Service	[0] Disabled	1 set-up	TRUE	–	Uint8
12-89	Transparent Socket Channel Port	4000 N/A	1 set-up	TRUE	0	Uint16
12-9* Advanced Ethernet Services						
12-90	Cable Diagnostic	[0] Disabled	1 set-up	TRUE	–	Uint8
12-91	Auto Cross Over	[1] Enabled	1 set-up	TRUE	–	Uint8
12-92	IGMP Snooping	[1] Enabled	1 set-up	TRUE	–	Uint8
12-93	Cable Error Length	0 N/A	1 set-up	TRUE	0	Uint16
12-94	Broadcast Storm Protection	-1 %	1 set-up	TRUE	0	Int8
12-95	Broadcast Storm Filter	[0] Broadcast only	1 set-up	TRUE	–	Uint8
12-96	Port Config	ExpressionLimit	1 set-up	TRUE	–	Uint8
12-98	Interface Counters	4000 N/A	All set-ups	TRUE	0	Uint32
12-99	Media Counters	0 N/A	All set-ups	TRUE	0	Uint32

5.2.12 13-** Smart Logic Control

Par. No. #	Parameter description	Default value	2-set-up	Change during operation	Conversion index	Type
13-0* SLC Settings						
13-00	SL Controller Mode	[0] Off	1 set-up	TRUE	-	Uint8
13-01	Start Event	[39] Start command	1 set-up	TRUE	-	Uint8
13-02	Stop Event	[40] Drive stopped	1 set-up	TRUE	-	Uint8
13-03	Reset SLC	[0] Do not reset SLC	1 set-up	TRUE	-	Uint8
13-1* Comparators						
13-10	Comparator Operand	[0] Disabled	1 set-up	TRUE	-	Uint8
13-11	Comparator Operator	[1] Approx.Equal (~)	1 set-up	TRUE	-	Uint8
13-12	Comparator Value	0 N/A	1 set-up	TRUE	-3	Int32
13-2* Timers						
13-20	SL Controller Timer	0 s	1 set-up	TRUE	-2	Uint32
13-4* Logic Rules						
13-40	Logic Rule Boolean 1	[0] False	1 set-up	TRUE	-	Uint8
13-41	Logic Rule Operator 1	[0] Disabled	1 set-up	TRUE	-	Uint8
13-42	Logic Rule Boolean 2	[0] False	1 set-up	TRUE	-	Uint8
13-43	Logic Rule Operator 2	[0] Disabled	1 set-up	TRUE	-	Uint8
13-44	Logic Rule Boolean 3	[0] False	1 set-up	TRUE	-	Uint8
13-5* States						
13-51	SL Controller Event	[0] False	1 set-up	TRUE	-	Uint8
13-52	SL Controller Action	[0] Disabled	1 set-up	TRUE	-	Uint8

5.2.13 14-** Special Functions

5

Par. No. #	Parameter description	Default value	4-set-up	Change during operation	Conversion index	Type
14-0* Inverter Switching						
14-01	Switching Frequency	ExpressionLimit	All set-ups	TRUE	-	Uint8
14-03	Overmodulation	[1] On	All set-ups	FALSE	-	Uint8
14-07	Dead Time Compensation Level	ExpressionLimit	All set-ups	FALSE	0	Uint8
14-08	Damping Gain Factor	ExpressionLimit	All set-ups	TRUE	0	Uint8
14-09	Dead Time Bias Current Level	ExpressionLimit	All set-ups	FALSE	0	Uint8
14-1* Mains On/Off						
14-10	Mains Failure	[0] No function	All set-ups	FALSE	-	Uint8
14-11	Mains Voltage at Mains Fault	342 V	All set-ups	TRUE	0	Uint16
14-12	Function at Mains Imbalance	[0] Trip	1 set-up	TRUE	-	Uint8
14-15	Kin. Backup Trip Recovery Level	ExpressionLimit	All set-ups	TRUE	-3	Uint32
14-2* Reset Functions						
14-20	Reset Mode	[0] Manual reset	All set-ups	TRUE	-	Uint8
14-21	Automatic Restart Time	10 s	All set-ups	TRUE	0	Uint16
14-22	Operation Mode	[0] Normal operation	1 set-up	TRUE	-	Uint8
14-24	Trip Delay at Current Limit	60 s	All set-ups	TRUE	0	Uint8
14-25	Trip Delay at Torque Limit	60 s	All set-ups	TRUE	0	Uint8
14-27	Action At Inverter Fault	[1] Warning	All set-ups	TRUE	-	Uint8
14-28	Production Settings	[0] No action	1 set-up	FALSE	-	Uint8
14-29	Service Code	0 N/A	1 set-up	TRUE	0	Uint32
14-3* Current Limit Ctrl.						
14-30	Current Lim Ctrl, Proportional Gain	100%	All set-ups	TRUE	0	Uint16
14-31	Current Lim Ctrl, Integration Time	0.020 s	All set-ups	TRUE	-3	Uint16
14-32	Current Lim Ctrl, Filter Time	5 ms	All set-ups	TRUE	-4	Uint16
14-4* Energy Optimising						
14-40	VT Level	66%	All set-ups	FALSE	0	Uint8
14-41	AEO Minimum Magnetisation	66%	All set-ups	FALSE	0	Uint8
14-44	d-axis current optimization for IPM	100%	All set-ups	TRUE	0	Uint8
14-5* Environment						
14-50	RFI Filter	[2] Grid Type	1 set-up	FALSE	-	Uint8
14-51	DC-Link Voltage Compensation	[1] On	All set-ups	FALSE	-	Uint8
14-52	Fan Control	[5] Constant-on mode	1 set-up	TRUE	-	Uint8
14-55	Output Filter	[0] No Filter	1 set-up	FALSE	-	Uint8
14-6* Auto Derate						
14-61	Function at Inverter Overload	[0] Trip	All set-ups	TRUE	-	Uint8
14-63	Min Switch Frequency	[2] 2.0 kHz	1 set-up	FALSE	-	Uint8
14-64	Dead Time Compensation Zero Current Level	[0] Disabled	All set-ups	FALSE	-	Uint8
14-65	Speed Derate Dead Time Compensation	ExpressionLimit	All set-ups	FALSE	0	Uint16
14-8* Options						
14-89	Option Detection	[0] Protect Option Config.	1 set-up	TRUE	-	Uint8
14-9* Fault Settings						
14-90	Fault Level	[3] Trip Lock	All set-ups	TRUE	-	Uint8

5.2.14 15-** Drive Information

Par. No. #	Parameter description	Default value	2-set-up	Change during operation	Conversion index	Type
15-0* Operating Data						
15-00	Operating hours	0 h	1 set-up	TRUE	74	Uint32
15-01	Running Hours	0 h	1 set-up	TRUE	74	Uint32
15-02	kWh Counter	0 kWh	1 set-up	TRUE	75	Uint32
15-03	Power Up's	0 N/A	1 set-up	TRUE	0	Uint32
15-04	Over Temp's	0 N/A	1 set-up	TRUE	0	Uint16
15-05	Over Volt's	0 N/A	1 set-up	TRUE	0	Uint16
15-06	Reset kWh Counter	[0] Do not reset	1 set-up	TRUE	-	Uint8
15-07	Reset Running Hours Counter	[0] Do not reset	1 set-up	TRUE	-	Uint8
15-3* Alarm Log						
15-30	Alarm Log: Error Code	0 N/A	1 set-up	TRUE	0	Uint8
15-31	InternalFaultReason	0 N/A	1 set-up	TRUE	0	Int16
15-4* Drive Identification						
15-40	FC Type	0 N/A	1 set-up	FALSE	0	VisStr[7]
15-41	Power Section	0 N/A	1 set-up	FALSE	0	VisStr[20]
15-42	Voltage	0 N/A	1 set-up	FALSE	0	VisStr[20]
15-43	Software Version	0 N/A	1 set-up	FALSE	0	VisStr[20]
15-44	Ordered TypeCode	0 N/A	1 set-up	FALSE	0	VisStr[41]
15-45	Actual Typecode String	0 N/A	All set-ups	FALSE	0	VisStr[40]
15-46	Drive Ordering No	0 N/A	1 set-up	FALSE	0	VisStr[9]
15-48	LCP Id No	0 N/A	1 set-up	FALSE	0	VisStr[21]
15-49	SW ID Control Card	0 N/A	1 set-up	FALSE	0	VisStr[21]
15-50	SW ID Power Card	0 N/A	1 set-up	FALSE	0	VisStr[21]
15-51	Drive Serial Number	0 N/A	1 set-up	FALSE	0	VisStr[13]
15-53	Power Card Serial Number	0 N/A	1 set-up	FALSE	0	VisStr[21]
15-6* Option Ident						
15-60	Option Mounted	ExpressionLimit	All set-ups	FALSE	0	VisStr[30]
15-61	Option SW Version	ExpressionLimit	All set-ups	FALSE	0	VisStr[20]
15-62	Option Ordering No	ExpressionLimit	All set-ups	FALSE	0	VisStr[8]
15-63	Option Serial No	ExpressionLimit	All set-ups	FALSE	0	VisStr[18]
15-70	Option in Slot A	0 N/A	All set-ups	FALSE	0	VisStr[30]
15-71	Slot A Option SW Version	0 N/A	All set-ups	FALSE	0	VisStr[20]
15-9* Parameter Info						
15-92	Defined Parameters	0 N/A	1 set-up	TRUE	0	Uint16
15-97	Application Type	0 N/A	1 set-up	TRUE	0	Uint32
15-98	Drive Identification	0 N/A	1 set-up	FALSE	0	VisStr[56]
15-99	Parameter Metadata	0 N/A	1 set-up	FALSE	0	Uint16

5.2.15 16-** Data Readouts

5

Par. No. #	Parameter description	Default value	2-set-up	Change during operation	Conversion index	Type
16-0* General Status						
16-00	Control Word	0 N/A	1 set-up	TRUE	0	Uint16
16-01	Reference [Unit]	0 ReferenceFeedbackUnit	1 set-up	TRUE	-3	Int32
16-02	Reference [%]	0%	1 set-up	TRUE	-1	Int16
16-03	Status Word	0 N/A	1 set-up	TRUE	0	Uint16
16-05	Main Actual Value [%]	0%	1 set-up	TRUE	-2	Int16
16-09	Custom Readout	0 CustomReadoutUnit	1 set-up	TRUE	-2	Int32
16-1* Motor Status						
16-10	Power [kW]	0 kW	1 set-up	TRUE	-3	Uint32
16-11	Power [hp]	0 hp	1 set-up	TRUE	-3	Uint32
16-12	Motor Voltage	0 V	1 set-up	TRUE	-1	Uint32
16-13	Frequency	0 Hz	1 set-up	TRUE	-1	Uint32
16-14	Motor current	0 A	1 set-up	TRUE	-2	Uint16
16-15	Frequency [%]	0%	1 set-up	TRUE	-1	Uint16
16-16	Torque [Nm]	0 Nm	All set-ups	FALSE	-1	Int32
16-17	Speed [RPM]	0 RPM	All set-ups	FALSE	0	Int32
16-18	Motor Thermal	0%	1 set-up	TRUE	0	Uint8
16-22	Torque [%]	0%	All set-ups	FALSE	0	Int16
16-3* Drive Status						
16-30	DC Link Voltage	0 V	1 set-up	TRUE	0	Uint32
16-33	Brake Energy /2 min	0 kW	All set-ups	FALSE	0	Uint32
16-34	Heatsink Temp.	0 °C	1 set-up	TRUE	100	Int8
16-35	Inverter Thermal	0%	1 set-up	TRUE	0	Uint8
16-36	Inv. Nom. Current	0 A	1 set-up	TRUE	-2	Uint16
16-37	Inv. Max. Current	0 A	1 set-up	TRUE	-2	Uint16
16-38	SL Controller State	0 N/A	1 set-up	TRUE	0	Uint8
16-39	Control Card Temp.	0 °C	All set-ups	FALSE	100	Uint16
16-5* Ref. & Feedb.						
16-50	External Reference	0%	1 set-up	TRUE	-1	Int16
16-52	Feedback[Unit]	0 ProcessCtrlUnit	1 set-up	TRUE	-3	Int32
16-53	Digi Pot Reference	0 N/A	All set-ups	FALSE	-2	Int16
16-57	Feedback [RPM]	0 RPM	All set-ups	FALSE	67	Int32
16-6* Inputs & Outputs						
16-60	Digital Input	0 N/A	1 set-up	TRUE	0	Uint16
16-61	Terminal 53 Setting	ExpressionLimit	1 set-up	TRUE	-	Uint8
16-62	Analog Input 53	1 N/A	1 set-up	TRUE	-2	Uint16
16-63	Terminal 54 Setting	ExpressionLimit	1 set-up	TRUE	-	Uint8
16-64	Analog Input AI54	1 N/A	1 set-up	TRUE	-2	Uint16
16-65	Analog Output 42 [mA]	0 mA	1 set-up	TRUE	-2	Uint16
16-66	Digital Output	0 N/A	1 set-up	TRUE	0	VisStr[5]
16-67	Pulse Input 29[Hz]	0 N/A	All set-ups	FALSE	0	Int32
16-68	Pulse Input 33 [Hz]	0 N/A	All set-ups	FALSE	0	Int32
16-69	Pulse Output 27 [Hz]	0 N/A	All set-ups	FALSE	0	Int32
16-70	Pulse Output 29 [Hz]	0 N/A	All set-ups	FALSE	0	Int32
16-71	Relay Output	0 N/A	1 set-up	TRUE	0	Uint16
16-72	Counter A	0 N/A	1 set-up	TRUE	0	Int16
16-73	Counter B	0 N/A	1 set-up	TRUE	0	Int16
16-79	Analog Output AO45	0 mA	1 set-up	TRUE	-2	Uint16

Par. No. #	Parameter description	Default value	2-set-up	Change during operation	Conversion index	Type
16-8* Fieldbus & FC Port						
16-80	Fieldbus CTW 1	0 N/A	1 set-up	TRUE	0	Uint16
16-82	Fieldbus REF 1	0 N/A	1 set-up	TRUE	0	Int16
16-84	Comm. Option STW	0 N/A	1 set-up	TRUE	0	Uint16
16-85	FC Port CTW 1	1084 N/A	1 set-up	FALSE	0	uint16
16-86	FC Port REF 1	0 N/A	1 set-up	TRUE	0	Int16
16-9* Diagnosis Readouts						
16-90	Alarm Word	0 N/A	1 set-up	TRUE	0	Uint32
16-91	Alarm Word 2	0 N/A	1 set-up	TRUE	0	Uint32
16-92	Warning Word	0 N/A	1 set-up	TRUE	0	Uint32
16-93	Warning Word 2	0 N/A	1 set-up	TRUE	0	Uint32
16-94	Ext. Status Word	0 N/A	1 set-up	TRUE	0	Uint32
16-95	Ext. Status Word 2	0 N/A	1 set-up	TRUE	0	Uint32
16-97	Alarm Word 3	0 N/A	1 set-up	TRUE	0	Uint32

5.2.16 17-** Feedback Options

Par. No. #	Parameter description	Default value	2-set-up	Change during operation	Conversion index	Type
17-1* Inc.Enc.Interface						
17-10	Signal Type	[1] RS422 (5 V TTL)	All set-ups	FALSE	-	Uint8
17-11	Resolution (PPR)	1024 N/A	All set-ups	FALSE	0	Uint16
17-5* Resolver Interface						
17-50	Poles	2 N/A	1 set-up	FALSE	0	Uint8
17-51	Input Voltage	7 V	1 set-up	FALSE	-1	Uint8
17-52	Input Frequency	10 kHz	1 set-up	FALSE	2	Uint8
17-53	Transformation Ratio	0.5 N/A	1 set-up	FALSE	-1	Uint8
17-56	Encoder Sim. Resolution	[0] Disabled	1 set-up	FALSE	-	Uint8
17-59	Resolver Interface	[0] Disabled	All set-ups	FALSE	-	Uint8
17-6* Monitoring and App.						
17-60	Feedback Direction	[0] Clockwise	All set-ups	FALSE	-	Uint8
17-61	Feedback Signal Monitoring	[1] Warning	All set-ups	TRUE	-	Uint8

5.2.17 18-** Data Readouts 2

Par. No. #	Parameter description	Default value	4-set-up	Change during operation	Conversion index	Type
18-8* Center Winder Readout						
18-81	Tension PID Output	0 Hz	1 set-up	TRUE	-3	Int32
18-82	Center Winder Output	0 Hz	1 set-up	TRUE	-3	Int32
18-83	Line Speed	0 Hz	1 set-up	TRUE	-3	Int32
18-84	Diameter	0%	1 set-up	TRUE	-3	Int32
18-85	Tapered Tension Set Point	0%	1 set-up	TRUE	-1	Int32
18-86	Tension Feedback	0%	1 set-up	TRUE	-1	Int32
18-9* PID Readouts						
18-90	Process PID Error	0%	All set-ups	FALSE	-1	Int16
18-91	Process PID Output	0%	All set-ups	FALSE	-1	Int16
18-92	Process PID Clamped Output	0%	All set-ups	FALSE	-1	Int16
18-93	Process PID Gain Scaled Output	0%	All set-ups	FALSE	-1	Int16

5.2.18 21-** Ext. Closed Loop

Par. No. #	Parameter description	Default value	4-set-up	Change during operation	Conversion index	Type
21-0* Ext. CL Autotuning						
21-09	Extended PID Enable	[0] Disabled	All set-ups	TRUE	-	UInt8
21-1* Ext. CL 1 Ref./Fb.						
21-11	Ext. 1 Minimum Reference	0 ExtPID1Unit	All set-ups	TRUE	-3	Int32
21-12	Ext. 1 Maximum Reference	100 ExtPID1Unit	All set-ups	TRUE	-3	Int32
21-13	Ext. 1 Reference Source	[0] No function	All set-ups	TRUE	-	UInt8
21-14	Ext. 1 Feedback Source	[0] No function	All set-ups	TRUE	-	UInt8
21-15	Ext. 1 Setpoint	0 ExtPID1Unit	All set-ups	TRUE	-3	Int32
21-17	Ext. 1 Reference [Unit]	0 ExtPID1Unit	All set-ups	TRUE	-3	Int32
21-18	Ext. 1 Feedback [Unit]	0 ExtPID1Unit	All set-ups	TRUE	-3	Int32
21-19	Ext. 1 Output [%]	0%	All set-ups	TRUE	0	Int32
Ext. CL 1 PID						
21-20	Ext. 1 Normal/Inverse Control	[0] Normal	All set-ups	TRUE	-	UInt8
21-21	Ext. 1 Proportional Gain	0.01 N/A	All set-ups	TRUE	-2	UInt16
21-22	Ext. 1 Integral Time	10000 s	All set-ups	TRUE	-2	UInt32
21-23	Ext. 1 Differentiation Time	0 s	All set-ups	TRUE	-2	UInt16
21-24	Ext. 1 Dif. Gain Limit	5 N/A	All set-ups	TRUE	-1	UInt16

5.2.19 22-** Application Functions

Par. No. #	Parameter description	Default value	2-set-up	Change during operation	Conversion index	Type
22-4* Sleep Mode						
22-40	Minimum Run Time	10 s	All set-ups	TRUE	0	Uint16
22-41	Minimum Sleep Time	10 s	All set-ups	TRUE	0	Uint16
22-43	Wake-Up Speed [Hz]	10 N/A	All set-ups	TRUE	-1	Uint16
22-44	Wake-Up Ref./FB Diff	10%	All set-ups	TRUE	0	Uint8
22-45	Setpoint Boost	0%	All set-ups	TRUE	0	Int8
22-46	Maximum Boost Time	60 s	All set-ups	TRUE	0	Uint16
22-47	Sleep Speed [Hz]	0 N/A	All set-ups	TRUE	-1	Uint16
22-6* Broken Belt Detection						
22-60	Broken Belt Function	[0] Off	All set-ups	TRUE	-	Uint8
22-61	Broken Belt Torque	10%	All set-ups	TRUE	0	Uint8
22-62	Broken Belt Delay	10 s	All set-ups	TRUE	0	Uint16

5.2.20 30-** Special Features

Par. No. #	Parameter description	Default value	2-set-up	Change during operation	Conversion index	Type
30-2* Adv. Start Adjust						
30-20	High Starting Torque Time [s]	ExpressionLimit	All set-ups	TRUE	-2	Uint16
30-21	High Starting Torque Current [%]	ExpressionLimit	All set-ups	TRUE	-1	Uint32
30-22	Locked Rotor Protection	[0] Off	All set-ups	TRUE	-	Uint8
30-23	Locked Rotor Detection Time [s]	0.10 s	All set-ups	TRUE	-2	Uint8

5.2.21 32-** Motion Control Basic Settings

Par. No. #	Parameter description	Default value	2-set-up	Change during operation	Conversion index	Type
32-11	User Unit Denominator	1 N/A	1 set-up	TRUE	0	Uint32
32-12	User Unit Numerator	1 N/A	1 set-up	TRUE	0	Uint32
32-67	Max. Tolerated Position Error	2000000 N/A	1 set-up	TRUE	0	Uint32
32-80	Maximum Allowed Velocity	1500 RPM	1 set-up	FALSE	67	Uint16
32-81	Motion Ctrl Quick Stop Ramp	1000 ms	1 set-up	TRUE	-3	Uint32

5.2.22 33-** Motion Control Adv. Settings

Par. No. #	Parameter description	Default value	2-set-up	Change during operation	Conversion index	Type
33-00	Force Home	[0] Home not forced	1 set-up	TRUE	-	Uint8
33-01	Home Offset	0 N/A	1 set-up	TRUE	0	Int32
33-02	Home Ramp Time	10 ms	1 set-up	TRUE	-3	Uint16
33-03	Homing Velocity	100 RPM	1 set-up	TRUE	67	Int16
33-04	Homing Type	[1] Reverse no index	1 set-up	TRUE	-	Uint8
33-41	Negative Software Limit	-500000 N/A	1 set-up	TRUE	0	Int32
33-42	Positive Software Limit	500000 N/A	1 set-up	TRUE	0	Int32
33-43	Negative Software Limit Active	[0] Inactive	1 set-up	TRUE	-	Uint8
33-44	Positive Software Limit Active	[0] Inactive	1 set-up	TRUE	-	Uint8
33-47	Target Position Window	0 N/A	1 set-up	TRUE	0	Uint16

5.2.23 34-** Motion Control Data Readouts

Par. No. #	Parameter description	Default value	2-set-up	Change during operation	Conversion index	Type
34-0* PCD Write Par.						
34-01	PCD 1 Write For Application	0 N/A	All set-ups	TRUE	0	Uint16
34-02	PCD 2 Write For Application	0 N/A	All set-ups	TRUE	0	Uint16
34-03	PCD 3 Write For Application	0 N/A	All set-ups	TRUE	0	Uint16
34-04	PCD 4 Write For Application	0 N/A	All set-ups	TRUE	0	Uint16
34-05	PCD 5 Write For Application	0 N/A	All set-ups	TRUE	0	Uint16
34-06	PCD 6 Write For Application	0 N/A	All set-ups	TRUE	0	Uint16
34-07	PCD 7 Write For Application	0 N/A	All set-ups	TRUE	0	Uint16
34-08	PCD 8 Write For Application	0 N/A	All set-ups	TRUE	0	Uint16
34-09	PCD 9 Write For Application	0 N/A	All set-ups	TRUE	0	Uint16
34-10	PCD 10 Write For Application	0 N/A	All set-ups	TRUE	0	Uint16
34-2* PCD Read Par.						
34-21	PCD 1 Read For Application	0 N/A	All set-ups	TRUE	0	Uint16
34-22	PCD 2 Read For Application	0 N/A	All set-ups	TRUE	0	Uint16
34-23	PCD 3 Read For Application	0 N/A	All set-ups	TRUE	0	Uint16
34-24	PCD 4 Read For Application	0 N/A	All set-ups	TRUE	0	Uint16
34-25	PCD 5 Read For Application	0 N/A	All set-ups	TRUE	0	Uint16
34-26	PCD 6 Read For Application	0 N/A	All set-ups	TRUE	0	Uint16
34-27	PCD 7 Read For Application	0 N/A	All set-ups	TRUE	0	Uint16
34-28	PCD 8 Read For Application	0 N/A	All set-ups	TRUE	0	Uint16
34-29	PCD 9 Read For Application	0 N/A	All set-ups	TRUE	0	Uint16
34-30	PCD 10 Read For Application	0 N/A	All set-ups	TRUE	0	Uint16
34-5* Process Data						
34-50	Actual Position	0 N/A	All set-ups	TRUE	0	Int32
34-56	Track Error	0 N/A	All set-ups	TRUE	0	Int32

5.2.24 37-** Application Settings

Par. No. #	Parameter description	Default value	2-set-up	Change during operation	Conversion index	Type
37-0* Application Mode						
37-00	Application Mode	[0] Drive mode	1 set-up	FALSE	-	Uint8
37-1* Position Control						
37-01	Pos. Feedback Source	[0] 24 V Encoder	1 set-up	FALSE	-	Uint8
37-02	Pos. Target	0 N/A	1 set-up	FALSE	0	Int32
37-03	Pos. Type	[0] Absolute	1 set-up	FALSE	-	Uint8
37-04	Pos. Velocity	100 RPM	1 set-up	FALSE	67	Uint16
37-05	Pos. Ramp Up Time	5000 ms	1 set-up	FALSE	-3	Uint32
37-06	Pos. Ramp Down Time	5000 ms	1 set-up	FALSE	-3	Uint32
37-07	Pos. Auto Brake Ctrl	[1] Enable	1 set-up	TRUE	-	Uint8
37-08	Pos. Hold Delay	0 ms	1 set-up	TRUE	-3	Uint32
37-09	Pos. Coast Delay	200 ms	1 set-up	TRUE	-3	Uint16
37-10	Pos. Brake Delay	200 ms	1 set-up	TRUE	-3	Uint16
37-11	Pos. Brake Wear Limit	0 N/A	1 set-up	TRUE	0	Uint32
37-12	Pos. PID Anti Windup	[1] Enable	1 set-up	TRUE	-	Uint8
37-13	Pos. PID Output Clamp	1000 N/A	1 set-up	TRUE	0	Uint16
37-14	Pos. Ctrl. Source	[0] DI	1 set-up	TRUE	-	Uint8
37-15	Pos. Direction Block	[0] No Blocking	1 set-up	TRUE	-	Uint8
37-16	Pos. Power Recovery	[1] Enable	1 set-up	TRUE	-	Uint8
37-17	Pos. Ctrl Fault Behaviour	[0] Ramp Down&Brake	1 set-up	FALSE	-	Uint8
37-18	Pos. Ctrl Fault Reason	[0] No Fault	1 set-up	TRUE	-	Uint8
37-19	Pos. New Index	0 N/A	1 set-up	TRUE	-	Uint8
37-2* Center Winder1 set-up						
37-20	Winder Mode Selection	[0] Wind	1 set-up	FALSE	-	Uint8
37-21	Tension Set Point	0%	1 set-up	TRUE	-1	Uint16
37-22	Taper Set Point	0%	1 set-up	TRUE	-1	Int16
37-23	Partial Roll Diameter Value	5%	1 set-up	FALSE	-3	Uint32
37-24	Core1 Diameter	5%	1 set-up	FALSE	-3	Uint32
37-25	Core2 Diameter	5%	1 set-up	FALSE	-3	Uint32
37-26	Winder Jog Speed	0%	1 set-up	TRUE	0	Uint8
37-27	TLD Low Limit	0%	1 set-up	TRUE	-1	Uint16
37-28	TLD High Limit	0%	1 set-up	TRUE	-1	Uint16
37-29	TLD Timer	0.001 s	1 set-up	TRUE	-3	Uint16
37-30	TLDOnDelay	[1] Enabled	1 set-up	TRUE	-	Uint8
37-31	Diameter Limit Detector	100%	1 set-up	TRUE	-3	Uint32
37-32	Initial Diameter Measurement	[0] Set diameter when diameter reset	1 set-up	FALSE	-	Uint8
37-33	Diameter Measurement Input	[0] No Function	1 set-up	FALSE	-	Uint8
37-34	Reading at Core	0 N/A	1 set-up	TRUE	-2	Int16
37-35	Reading at Full Roll	0 V	1 set-up	TRUE	-2	Int16
37-36	Tension Set Point Input	[0] Par.3721	1 set-up	FALSE	-	Uint8
37-37	Taper Set Point Input	[0] Par.3722	1 set-up	FALSE	-	Uint8
37-38	Tension Feedback Input	[0] No Function	1 set-up	FALSE	-	Uint8
37-39	Tension Feedback Type	[0] Load cell	1 set-up	FALSE	-	Uint8
37-40	Center Winder Cmd Src	[1] Parameter 3754~3759 control the functions	1 set-up	TRUE	-	Uint8
37-41	Diameter Change Rate	0.001%	1 set-up	TRUE	-3	Uint8
37-42	Tapered Tension Change Rate	0.1%	1 set-up	TRUE	-1	Uint8

Par. No. #	Parameter description	Default value	2-set-up	Change during operation	Conversion index	Type
37-43	Diameter Calculator Min Speed	0%	1 set-up	TRUE	0	Uint16
37-44	Line Acceleration Feed Forward	0 N/A	1 set-up	TRUE	-3	Int16
37-45	Line Speed Source	[0] No function	1 set-up	FALSE	-	Uint8
37-46	Winder Speed Match Scale	1 N/A	1 set-up	FALSE	-3	Uint32
37-47	Tension PID Profile	0%	1 set-up	TRUE	-2	Uint16
37-48	Tension PID Proportional Gain	0 N/A	1 set-up	TRUE	-2	Uint16
37-49	Tension PID Derivate Time	0 s	1 set-up	TRUE	-2	Uint16
37-50	Tension PID Integral Time	501 s	1 set-up	TRUE	-2	Uint32
37-51	Tension PID Out Limit	0%	1 set-up	TRUE	-3	Uint32
37-52	Tension PID Der Gain Limit	5 N/A	1 set-up	TRUE	-1	Uint16
37-53	Tension PID Anti Windup	[1] Enabled	1 set-up	TRUE	-	Uint8
37-54	Winder Jog Reverse	[0] No Function	1 set-up	TRUE	-	Uint8
37-55	Winder Jog Forward	[0] No function	1 set-up	TRUE	-	Uint8
37-56	New Diameter Select	[0] Core diameter	1 set-up	FALSE	-	Uint8
37-57	Tension On/Off	[0] Off	1 set-up	TRUE	-	Uint8
37-58	Core Select	[0] Core1 diameter	1 set-up	FALSE	-	Uint8
37-59	Diameter Reset	[0] Off	1 set-up	FALSE	-	Uint8

6 Troubleshooting

6.1 Warnings and Alarms

When the frequency converter fault circuitry detects a fault condition or a pending fault, a warning or alarm is issued. A flashing display on the LCP indicates an alarm or warning condition and the associated number code on line 2. Sometimes a warning precedes an alarm.

6.1.1 Alarms

An alarm causes the frequency converter to trip (suspend operation). The frequency converter has 3 trip conditions, which are shown in line 1:

Trip (auto restart)

The frequency converter is programmed to restart automatically after the fault is removed. The number of automatic reset attempts can be continuous or limited to a programmed number of attempts. If the selected number of automatic reset attempts is exceeded, the trip condition changes to trip (reset).

Trip (reset)

Requires resetting of the frequency converter before operation after a fault is cleared. To reset the frequency converter manually, press [Reset] or use a digital input, or a fieldbus command. For NLCP, stop and reset are the same key, [Off/Reset]. If [Off/Reset] is used to reset the frequency converter, press [Start] to initiate a run command in either hand-on mode or auto-on mode.

Trip lock (disc>mains)

Disconnect the mains AC input power to the frequency converter long enough for the display to go blank. Remove the fault condition and reapply power. Following power-up, the fault indication changes to trip (reset) and allows for manual, digital, or fieldbus reset.

6.1.2 Warnings

During a warning, the frequency converter remains operational, although the warning flashes for as long as the condition exists. The frequency converter could, however, reduce the warning condition. For example, if the warning shown was *warning 12, Torque Limit*, the frequency converter would reduce speed to compensate for the overcurrent condition. Sometimes, if the condition is not corrected or worsens, an alarm condition is activated and the frequency converter stops output to the motor terminals. Line 1 identifies the warning in plain language, and line 2 identifies the warning number.

6.1.3 Warning/alarm Messages

The LEDs on the front of the frequency converter and a code in the display signal a warning or an alarm.

LED indication	
Warning	Yellow
Alarm	Flashing red

Table 6.1 Control Terminals and Associated Parameter

A **warning** indicates a condition that requires attention, or a trend that would eventually require attention. A warning remains active until the cause is no longer present. Under some circumstances, motor operation could continue.

An alarm triggers a **trip**. The trip removes power to the motor. It can be reset after the condition has been cleared by pressing [Reset], or through a digital input (*parameter group 5-1* Digital Inputs*). The event that caused an alarm cannot damage the frequency converter, or cause a dangerous condition. Alarms must be reset to restart operation once their cause has been rectified.

The reset can be done in 3 ways:

- Press [Reset].
- A digital reset input.
- Serial communication/optional fieldbus reset signal.

NOTICE

After a manual reset pressing [Reset], press [Auto On] to restart the motor.

A warning precedes an alarm.

A trip lock is an action when an alarm occurs which can damage the frequency converter or connected equipment. Power is removed from the motor. A trip lock can only be reset after a cycling power has cleared the condition. Once the problem has been rectified, only the alarm continues flashing until the frequency converter is reset.

The warnings and alarms are explained in *Table 6.2*.

Number	Description	Warning	Alarm	Trip lock	Cause
2	Live zero error	X	X	-	Signal on terminal 53 or 54 is less than 50% of value set in <i>parameter 6-10 Terminal 53 Low Voltage</i> , <i>parameter 6-12 Terminal 53 Low Current</i> , <i>parameter 6-20 Terminal 54 Low Voltage</i> , and <i>parameter 6-22 Terminal 54 Low Current</i> .
3	No motor	X	-	-	No motor has been connected to the output of the frequency converter, or 1 motor phase is missing.
4	Mains phase loss ¹⁾	X	X	X	Missing phase on supply side, or the voltage imbalance is too high. Check the supply voltage.
7	DC overvoltage ¹⁾	X	X	-	Intermediate circuit voltage exceeds limit.
8	DC undervoltage ¹⁾	X	X	-	Intermediate circuit voltage drops below the voltage warning low limit.
9	Inverter overloaded	X	X	-	More than 100% load for too long.
10	Motor ETR overtemperature	X	X	-	Motor is too hot due to more than 100% load for too long.
11	Motor thermistor overtemperature	X	X	-	Thermistor or thermistor connection is disconnected.
12	Torque limit	X	X	-	Torque exceeds value set in either <i>parameter 4-16 Torque Limit Motor Mode</i> or <i>parameter 4-17 Torque Limit Generator Mode</i> .
13	Overcurrent	X	X	X	Inverter peak current limit is exceeded. For J1–J6 units, if this alarm occurs on power-up, check whether power cables are mistakenly connected to the motor terminals.
14	Earth fault	-	X	X	Discharge from output phases to ground.
16	Short circuit	-	X	X	Short circuit in motor or on motor terminals. For J7 units, if this alarm occurs on power-up, check whether power cables are mistakenly connected to the motor terminals.
17	Control word timeout	X	X	-	No communication to frequency converter.
18	Start failed	-	X	-	-
25	Brake resistor short-circuited	-	X	X	Brake resistor is short-circuited, thus the brake function is disconnected.
26	Brake overload	X	X	-	The power transmitted to the brake resistor over the last 120 s exceeds the limit. Possible corrections: Decrease brake energy via lower speed or longer ramp time.
27	Brake IGBT/Brake chopper short-circuited	-	X	X	Brake transistor is short-circuited, thus brake function is disconnected.
28	Brake check	-	X	-	Brake resistor is not connected/working.
30	U phase loss	-	X	X	Motor phase U is missing. Check the phase.
31	V phase loss	-	X	X	Motor phase V is missing. Check the phase.
32	W phase loss	-	X	X	Motor phase W is missing. Check the phase.
34	Fieldbus fault	X	X	-	PROFIBUS communication issues have occurred.
35	Option fault	-	X	-	Fieldbus or option B detects internal faults.
36	Mains failure	X	X	-	This warning/alarm is only active if the supply voltage to the frequency converter is less than the value set in <i>parameter 14-11 Mains Fault Voltage Level</i> , and <i>parameter 14-10 Mains Failure</i> is NOT set to [0] No Function.
38	Internal fault	-	X	X	Contact the local Danfoss supplier.
40	Overload T27	X	-	-	Check the load connected to terminal 27 or remove short-circuit connection.
41	Overload T29	X	-	-	Check the load connected to terminal 29 or remove short-circuit connection.
46	Gate drive voltage fault	-	X	X	-

Number	Description	Warning	Alarm	Trip lock	Cause
47	24 V supply low	X	X	X	24 V DC may be overloaded.
50	AMA calibration	-	X	-	-
51	AMA check U_{nom} and I_{nom}	-	X	-	Wrong setting for motor voltage and/or motor current.
52	AMA low I_{nom}	-	X	-	Motor current is too low. Check the settings.
53	AMA big motor	-	X	-	The power size of the motor is too large for the AMA to operate.
54	AMA small motor	-	X	-	The power size of the motor is too small for the AMA to operate.
55	AMA parameter range	-	X	-	The parameter values of the motor are outside of the acceptable range. AMA does not run.
56	AMA interrupt	-	X	-	The AMA is interrupted.
57	AMA timeout	-	X	-	-
58	AMA internal	-	X	-	Contact Danfoss.
59	Current limit	X	X	-	Frequency converter overload.
60	External Interlock	-	X	-	-
61	Feedback error	X	X	-	-
63	Mechanical brake low	-	X	-	Actual motor current has not exceeded release brake current within start delay time window.
65	Control card temp	X	X	X	The cutout temperature of the control card is 80 °C (176 °F).
69	Power card temp	X	X	X	-
70	Illegal FC config	-	X	X	-
80	Frequency converter initialized to default value	-	X	-	All parameter settings are initialized to default settings.
87	Auto DC brake	X	-	-	Occurs in IT mains when the frequency converter coasts and the DC voltage are higher than 830 V. Energy on DC-link is consumed by the motor. This function can be enabled/disabled in <i>parameter 0-07 Auto DC Braking</i> .
90	Feedback monitor	X	X	-	A feedback fault is detected by option B.
95	Broken belt	X	X	-	-
99	Locked rotor	-	X	-	-
101	Flow/pressure information missing	-	X	X	-
120	Position control fault	-	X	-	-
124	Tension limit	-	X	-	-
126	Motor rotating	-	X	-	-
127	Back EMF too high ²⁾	X	-	-	Try to start PM motor which is rotating in an abnormal high speed.
250	New spare part	-	X	X	-
251	New type code	-	X	X	-

Table 6.2 Warnings and Alarms Code List

1) These faults may be caused by mains distortions. Installing a Danfoss line filter may rectify this problem.

2) For enclosure size J7, the warning can also be caused by high UDC voltage.

For diagnosis, read out the alarm words, warning words, and extended status words.

Bit	Hex	Dec	Alarm word (parameter 1 6-90 Alarm Word)	Alarm word 2 (parameter 16-91 Alarm Word 2)	Alarm word 3 (parameter 1 6-97 Alarm Word 3)	Warning word (parameter 16- 92 Warning Word)	Warning word 2 (parameter 16 -93 Warning Word 2)	Extended status word (parameter 16- 94 Ext. Status Word)	Extended status word 2 (parameter 16-95 Ext . Status Word 2)
0	000000 01	1	Brake check	Reserved	Reserved	Reserved	Reserved	Ramping	Off
1	000000 02	2	Pwr. card temp	Gate drive voltage fault	Reserved	Pwr. card temp	Reserved	AMA tuning	Hand/Auto
2	000000 04	4	Earth fault	Reserved	Reserved	Reserved	Reserved	Start CW/CCW	PROFIBUS OFF1 active
3	000000 08	8	Ctrl. card temp	Reserved	Reserved	Ctrl. card temp	Reserved	Slowdown	PROFIBUS OFF2 active
4	000000 10	16	Ctrl. word TO	Illegal FC config	Reserved	Ctrl. word TO	Reserved	Catch up	PROFIBUS OFF3 active
5	000000 20	32	Overcurrent	Reserved	Reserved	Overcurrent	Reserved	Feedback high	Reserved
6	000000 40	64	Torque limit	Reserved	Reserved	Torque limit	Reserved	Feedback low	Reserved
7	000000 80	128	Motor Th. over	Reserved	Reserved	Motor Th. over	Reserved	Output current high	Control ready
8	000001 00	256	Motor ETR over	Broken belt	Reserved	Motor ETR over	Broken belt	Output current low	Frequency converter ready
9	000002 00	512	Inverter overld.	Reserved	Reserved	Inverter overld.	Reserved	Output freq. high	Quick stop
10	000004 00	1024	DC undervolt.	Start failed	Reserved	DC undervolt.	Reserved	Output freq. low	DC brake
11	000008 00	2048	DC overvolt.	Reserved	Reserved	DC overvolt.	Reserved	Brake check OK	Stop
12	000010 00	4096	Short circuit	External interlock	Reserved	Reserved	Reserved	Braking max	Latched
13	000020 00	8192	Reserved	Reserved	Reserved	Reserved	Reserved	Braking	Reserved
14	000040 00	16384	Mains ph. loss	Reserved	Reserved	Mains ph. loss	Reserved	Reserved	Freeze output
15	000080 00	32768	AMA not OK	Reserved	Reserved	No motor	Auto DC brake	OVC active	Reserved
16	000100 00	65536	Live zero error	Reserved	Reserved	Live zero error	Reserved	AC brake	Jog
17	000200 00	131072	Internal fault	Reserved	Reserved	Reserved	Reserved	Reserved	Reserved
18	000400 00	262144	Brake overload	Reserved	Reserved	Brake resistor power limit	Reserved	Reserved	Start
19	000800 00	524288	U phase loss	Reserved	Reserved	Reserved	Reserved	Reference high	Reserved
20	001000 00	1048576	V phase loss	Option detection	Reserved	Reserved	Overload T27	Reference low	Start delay
21	002000 00	2097152	W phase loss	Option fault	Reserved	Reserved	Reserved	Reserved	Sleep

Bit	Hex	Dec	Alarm word (parameter 1 6-90 Alarm Word)	Alarm word 2 (parameter 16-91 Alarm Word 2)	Alarm word 3 (parameter 1 6-97 Alarm Word 3)	Warning word (parameter 16- 92 Warning Word)	Warning word 2 (parameter 16 -93 Warning Word 2)	Extended status word (parameter 16- 94 Ext. Status Word)	Extended status word 2 (parameter 16-95 Ext . Status Word 2)
22	004000 00	4194304	Fieldbus fault	Locked rotor	Reserved	Fieldbus fault	Reserved	Reserved	Sleep boost
23	008000 00	8388608	24 V supply low	Position ctrl. fault	Reserved	24 V supply low	Reserved	Reserved	Running
24	010000 00	16777216	Mains failure	Tension Limit	Reserved	Mains failure	Reserved	Reserved	Bypass
25	020000 00	33554432	Reserved	Current limit	Reserved	Current limit	Reserved	Reserved	Reserved
26	040000 00	67108864	Brake resistor	Reserved	Reserved	Reserved	Reserved	Reserved	External interlock
27	080000 00	13421772 8	Brake IGBT	Reserved	Reserved	Reserved	Reserved	Reserved	Reserved
28	100000 00	26843545 6	Option change	Feedback fault	Reserved	Encoder loss	Reserved	Reserved	FlyStart active
29	200000 00	53687091 2	Frequency converter initialized	Encoder loss	Reserved	Reserved	Back EMF too high	Reserved	Heat sink clean warning
30	400000 00	10737418 24	Reserved	Reserved	Reserved	Reserved	Reserved	Reserved	Reserved
31	800000 00	21474836 48	Mech. brake low	Reserved	Reserved	Reserved	Reserved	Database busy	Reserved

Table 6.3 Description of Alarm Word, Warning Word, and Extended Status Word

The alarm words, warning words and extended status words can be accessed via fieldbus or optional fieldbus for diagnosis.

WARNING/ALARM 2, Live zero error

This warning or alarm only appears if programmed in *parameter 6-01 Live Zero Timeout Function*. The signal on 1 of the analog inputs is less than 50% of the minimum value programmed for that input. Broken wiring or faulty device sending the signal can cause this condition.

Troubleshooting

- Check connections on all the analog input terminals. Control card terminals 53 and 54 for signals, terminal 55 common.
- Check that the frequency converter programming and switch settings match the analog signal type.
- Perform the input terminal signal test.

WARNING/ALARM 4, Mains phase loss

A phase is missing on the supply side, or the mains voltage imbalance is too high. This message also appears for a fault in the input rectifier. Options are programmed in *parameter 14-12 Function at Mains Imbalance*.

Troubleshooting

- Check the supply voltage and supply currents to the frequency converter.

WARNING/ALARM 7, DC overvoltage

If the DC-link voltage exceeds the limit, the frequency converter trips after a time.

Troubleshooting

- Extend the ramp time.
- Change the ramp type.

WARNING/ALARM 8, DC under voltage

If the DC-link voltage (DC-link) drops below the undervoltage limit, the frequency converter trips after a fixed time delay. The time delay varies with unit size.

Troubleshooting

- Check that the supply voltage matches the frequency converter voltage.
- Perform the input voltage test.
- Perform the soft charge circuit test.

WARNING/ALARM 9, Inverter overload

The frequency converter is about to cut out because of an overload (too high current for too long). The counter for electronic, thermal inverter protection issues a warning at 90% and trips at 100%, while giving an alarm. The frequency converter cannot be reset until the counter is below 0%.

The fault occurs when the frequency converter has run with more than 100% overload for too long.

Troubleshooting

- Compare the output current shown on the LCP with the frequency converter rated current.
- Compare the output current shown on the LCP with measured motor current.

- Show the thermal frequency converter load on the LCP and monitor the value. When running above the frequency converter continuous current rating, the counter increases. When running below the frequency converter continuous current rating, the counter decreases.

WARNING/ALARM 10, Motor overload temperature

According to the electronic thermal protection (ETR), the motor is too hot. Select whether the frequency converter issues a warning or an alarm when the counter reaches 100% in *parameter 1-90 Motor Thermal Protection*. The fault occurs when the motor runs with more than 100% overload for too long.

Troubleshooting

- Check for motor overheating.
- Check if the motor is mechanically overloaded.
- Check that the motor current set in *parameter 1-24 Motor Current* is correct.
- Ensure that motor data in *parameters 1-20 to 1-25* is set correctly.
- Running AMA in *parameter 1-29 Automatic Motor Adaptation (AMA)* tunes the frequency converter to the motor more accurately and reduces thermal loading.

WARNING/ALARM 11, Motor thermistor over temp

Check whether the thermistor is disconnected. Select whether the frequency converter issues a warning or an alarm in *parameter 1-90 Motor Thermal Protection*.

Troubleshooting

- Check for motor overheating.
- Check if the motor is mechanically overloaded.
- When using terminal 53 or 54, check that the thermistor is connected correctly between either terminal 53 or 54 (analog voltage input) and terminal 50 (+10 V supply). Also check that the terminal switch for 53 or 54 is set for voltage. Check that *parameter 1-93 Thermistor Resource* selects terminal 53 or 54.
- When using terminal 18, 19, 31, 32, or 33 (digital inputs), check that the thermistor is connected correctly between the digital input terminal used (digital input PNP only) and terminal 50. Select the terminal to use in *parameter 1-93 Thermistor Resource*.

WARNING/ALARM 12, Torque limit

The torque has exceeded the value in *parameter 4-16 Torque Limit Motor Mode* or the value in *parameter 4-17 Torque Limit Generator Mode*. *Parameter 14-25 Trip Delay at Torque Limit* can change this warning from a warning-only condition to a warning followed by an alarm.

Troubleshooting

- If the motor torque limit is exceeded during ramp-up, extend the ramp-up time.
- If the generator torque limit is exceeded during ramp-down, extend the ramp-down time.
- If torque limit occurs while running, increase the torque limit. Make sure that the system can operate safely at a higher torque.
- Check the application for excessive current draw on the motor.

WARNING/ALARM 13, Over current

The inverter peak current limit (approximately 200% of the rated current) is exceeded. The warning lasts about 5 s, then the frequency converter trips and issues an alarm. Shock loading or fast acceleration with high-inertia loads can cause this fault.

Troubleshooting

- Remove power and check if the motor shaft can be turned.
- Check that the motor size matches the frequency converter.
- Check *parameters 1-20 to 1-25* for correct motor data.

ALARM 14, Earth (ground) fault

There is current from the output phases to ground, either in the cable between the frequency converter and the motor, or in the motor itself.

Troubleshooting

- Remove power to the frequency converter and repair the ground fault.
- Check for ground faults in the motor by measuring the resistance to ground of the motor cables and the motor with a megohmmeter.

ALARM 16, Short circuit

There is short-circuiting in the motor or motor wiring.

- Remove power to the frequency converter and repair the short circuit.

WARNING/ALARM 17, Control word timeout

There is no communication to the frequency converter. The warning is only active when *parameter 8-04 Control Word Timeout Function* is NOT set to [0] Off.

If *parameter 8-04 Control Word Timeout Function* is set to [5] Stop and Trip, a warning appears. The frequency converter then ramps down until it trips, while giving an alarm. *Parameter 8-03 Control Timeout Time* could possibly be increased.

Troubleshooting

- Check connections on the serial communication cable.
- Increase *parameter 8-03 Control Word Timeout Time*.

- Check the operation of the communication equipment.
- Verify a proper installation based on EMC requirements.

ALARM 18, Start failed

The speed cannot exceed the value set in *parameter 1-78 Compressor Start Max Speed [Hz]* during start within the allowed time which is set in *parameter 1-79 Compressor Start Max Time to Trip*. The alarm may be caused by a blocked motor.

WARNING 25, Brake resistor short circuit

The brake resistor is monitored during start-up. If a short circuit occurs, the brake function is disabled and the alarm appears. The frequency converter is tripped.

Troubleshooting

- Remove the power to the frequency converter and check the connection of the brake resistor.

WARNING/ALARM 26, Brake resistor power limit

The power transmitted to the brake resistor is calculated as a mean value over the last 120 s of run time. The calculation is based on the DC-link voltage and the brake resistor value set in *parameter 2-11 Brake Resistor (ohm)*. The warning is active when the dissipated braking power is higher than the value set in *parameter 2-12 Brake Power Limit (kW)*. The frequency converter trips if the warning persists for 1200 s.

Troubleshooting

- Decrease brake energy via lower speed or longer ramp time.

WARNING/ALARM 27, Brake chopper fault

The brake transistor is monitored during start-up. If a short circuit occurs, the brake function is disabled, and an alarm is issued. The frequency converter is tripped.

Troubleshooting

- Remove the power to the frequency converter and remove the brake resistor.

WARNING/ALARM 28, Brake check failed

The brake resistor is not connected or not working.

Troubleshooting

- Check if brake resistor is connected or it is too large for the frequency converter.

ALARM 30, Motor phase U missing

Motor phase U between the frequency converter and the motor is missing.

Troubleshooting

- Remove power from the frequency converter and check motor phase U.

ALARM 31, Motor phase V missing

Motor phase V between the frequency converter and the motor is missing.

Troubleshooting

- Remove power from the frequency converter and check motor phase V.

ALARM 32, Motor phase W missing

Motor phase W between the frequency converter and the motor is missing.

Troubleshooting

- Remove power from the frequency converter and check motor phase W.

WARNING/ALARM 34, communication fault

The fieldbus on the communication option card is not working.

ALARM 38, Internal fault

When an internal fault occurs, a code number is shown.

Troubleshooting

See *Table 6.4* for the causes and solutions for different internal faults. If the fault persists, contact the Danfoss supplier or service department for assistance.

Fault number	Cause	Solution
5632	Option hardware version error	The hardware version of the option or the fieldbus variant is not compatible with the frequency converter software.
5888	Option software version error	The software version of the option or the fieldbus variant is not compatible with the frequency converter software. Change either the fieldbus software or the frequency converter software.
6144	The option is not supported	Check if the product supports this option.
6400	The option combination error	Remove the option.
Other	Other internal faults	Power cycle the frequency converter. If the alarm occurs again, contact a Danfoss supplier.

Table 6.4 Internal Fault List

Fault number	Cause	Solution
140–142	Power board EEPROM data error	Upgrade the software in the frequency converter to the latest version.
176	The firmware in the frequency converter does not match the frequency converter.	Upgrade the software in the frequency converter to the latest version.
256	Flash ROM checksum error	Upgrade the software in the frequency converter to the latest version.
2304	Firmware mismatch between the control card and the power card.	Upgrade the software in the frequency converter to the latest version.
2560	Communication error between the control card and the power card.	Upgrade the software in the frequency converter to the latest version. If the alarm occurs again, check the connection between the control card and the power card.
3840	Serial flash version error	Upgrade the software in the frequency converter to the latest version.
4608	Frequency converter power size error	Upgrade the software in the frequency converter to the latest version. If the alarm occurs again, contact a Danfoss supplier.

WARNING 40, Overload of digital output terminal 27

Check the load connected to terminal 27 or remove the short-circuit connection. Check *parameter 5-00 Digital I/O Mode* and *parameter 5-01 Terminal 27 Mode*.

WARNING 41, Overload of digital output terminal 29

Check the load connected to terminal 29 or remove the short circuit connection. Check *parameter 5-00 Digital I/O Mode* and *parameter 5-02 Terminal 29 Mode*.

ALARM 46, Power card supply

The supply for the gate drive on the power card is out of range. It is generated by the switch mode supply (SMPS) on the power card.

Troubleshooting

- Check for a defective power card.

WARNING 47, 24 V supply low

The 24 V DC is measured on the control card.

ALARM 50, AMA calibration failed

A calibration error has occurred. Contact a Danfoss supplier or the Danfoss Service Department.

ALARM 51, AMA check U_{nom} and I_{nom}

The settings for motor voltage, motor current, and motor power are wrong.

Troubleshooting

- Check the settings in *parameters 1-20 to 1-25*.

ALARM 52, AMA low I_{nom}

The motor current is too low.

Troubleshooting

- Check the setting in *parameter 1-24 Motor Current*.

ALARM 53, AMA motor too big

The motor is too large for the AMA to operate.

ALARM 54, AMA motor too small

The motor is too small for the AMA to operate.

ALARM 55, AMA parameter out of range

The parameter values of the motor are outside of the acceptable range. The AMA does not run.

ALARM 56, AMA interrupted by user

The AMA is manually interrupted.

ALARM 57, AMA internal fault

Try to restart the AMA again. Repeated restarts can overheat the motor.

ALARM 58, Internal fault

Contact a Danfoss supplier.

WARNING 59, Current limit

The current is higher than the value in *parameter 4-18 Current Limit*.

Troubleshooting

- Ensure that motor data in *parameters 1-20 to 1-25* is set correctly.
- Possibly increase the current limit.
- Be sure that the system can operate safely at a higher limit.

ALARM 60, External interlock

A digital input signal indicates a fault condition external to the frequency converter. An external interlock has commanded the frequency converter to trip.

Troubleshooting

- Clear the external fault condition.
- To resume normal operation, apply 24 V DC to the terminal programmed for external interlock.
- Reset the frequency converter.

WARNING/ALARM 61, Feedback error

An error between calculated speed and speed measurement from feedback device.

Troubleshooting

- Check the settings for warning/alarm/disabling in *parameter 4-30 Motor Feedback Loss Function*.
- Set the tolerable error in *parameter 4-31 Motor Feedback Speed Error*.
- Set the tolerable feedback loss time in *parameter 4-32 Motor Feedback Loss Timeout*.

ALARM 63, Mechanical brake low

The actual motor current has not exceeded the release brake current within the start delay time window.

WARNING/ALARM 65, Control card over temperature

The cutout temperature of the control card has exceeded the upper limit.

Troubleshooting

- Check that the ambient operating temperature is within the limits.
- Check the fan operation.
- Check the control card.

ALARM 67, Option module configuration has changed

One or more options have either been added or removed since the last power-down. Check that the configuration change is intentional and reset the unit.

ALARM 68, Safe stop activated

Safe Torque Off (STO) is activated. If STO is in manual restart mode (default), to resume normal operation, apply 24 V DC to terminals 37 and 38 and initiate a reset signal (via fieldbus, digital I/O, or [Reset]/[Off Reset] key). If STO is in automatic restart mode, applying 24 V DC to terminals 37 and 38 automatically resumes the frequency converter to normal operation.

ALARM 69, Power card temperature Power card temperature

The cutout temperature of the power card has exceeded the upper limit.

Troubleshooting

- Check that the ambient operating temperature is within limits.
- Check fan operation.
- Check the power card.

ALARM 80, Drive initialised to default value

Parameter settings are initialized to default settings after a manual reset.

Troubleshooting

- To clear the alarm, reset the unit.

WARNING 87, Auto DC-Braking

Occurs in IT mains when the frequency converter coasts, and the DC voltage is higher than 830 V for 400 V units and 425 V for 200 V units. The motor consumes energy on the DC link. This function can be enabled/disabled in *parameter 0-07 Auto DC Braking*.

ALARM 88, Option detection

A new option configuration has been detected. Set *parameter 14-89 Option Detection* to [1] *Enable Option Change*, and power cycle the frequency converter to accept the new configuration.

ALARM 95, Broken belt

Torque is below the torque level set for no load, indicating a broken belt. *Parameter 22-60 Broken Belt Function* is set for alarm.

Troubleshooting

- Troubleshoot the system and reset the frequency converter after clearing the fault.

ALARM 99, Locked Rotor

The rotor is blocked. It is only enabled for PM motor control.

Troubleshooting

- Check if the motor shaft is locked.
- Check if the start current triggers the current limit set in *parameter 4-18 Current Limit*.
- Check if it increases the value in *parameter 30-23 Locked Rotor Detection Time [s]*.

ALARM 126, Motor Rotating

During AMA start-up, the motor is rotating. It is only valid for PM motor.

Troubleshooting

- Check if the motor is rotating before starting the AMA.

WARNING 127, Back EMF too High

This warning applies to PM motors only. When the back EMF exceeds $90\% \times U_{invmax}$ (overvoltage threshold) and does not drop to normal level within 5 s, this warning is reported. The warning remains until the back EMF returns to a normal level.

Index

A

Abbreviations..... 3

Adjustable warning..... 56

Alarm log..... 19, 106

AMA..... 5, 154, 156

Analog signal..... 154

Approvals and certifications..... 4

Auto on..... 19

Automatic motor adaptation..... 5, 23, 37

B

Brake

- energy function, 2-1* 46
- power..... 5
- resistor..... 5
- resistor power limit..... 155

Break-away torque..... 4

Broken-belt detection..... 116

Broken-belt torque..... 116

C

Catch up..... 59

Coast..... 4

Comparator..... 95

Control

- cable..... 8
- terminal..... 19, 152
- Current limit control..... 104
- Process control feedback..... 76
- Process PID control..... 76
- Speed PID control..... 74
- Torque PI control..... 76

Control card

- Control card..... 154

Current rating..... 154

D

Data readout..... 108

DC brake current..... 45

DC brake cut-in speed..... 46

DC braking time..... 45

Default setting..... 20, 125

Digital Input..... 57

Discharge time..... 11

E

Electrical wiring..... 7

Electronic thermal relay..... 5

see also *ETR*

EMC..... 155

ETR..... 5, 109

- see also *Electronic thermal relay*

External process PID control, 7-5*..... 78

F

Fault

- log..... 19

FC MC protocol..... 80

Feedback conversion, 7-6* 79

Fieldbus..... 153

Freeze output..... 4

Frequency converter identification..... 106

Frequency converter status..... 109

G

General settings..... 79

General status..... 108

H

Hand on..... 19

High altitude..... 12

High voltage..... 11

I

Identification, frequency converter..... 106

Initialization

- Manual procedure..... 21
- Procedure..... 20

Input signal..... 157

Inputs

- Analog input..... 4, 5, 154
- Digital input mode..... 57

Intermittent duty cycle..... 5

Inverter switching..... 100

J

Jog..... 4

L

LCP..... 4, 5, 149

LCP copy/save..... 32

Leakage current..... 12

LED..... 149

Live zero..... 71

Load compensation..... 33

Load sharing..... 11, 102

Local control.....	19	Port setting.....	80
Local reference.....	24	Potentiometer reference.....	10
Logic rule.....	96	Power cycle.....	5
M		Preset reference.....	49
Main menu.....	16, 19	Programming.....	19, 20, 154
Main reactance.....	37, 38	Pulse input.....	67
Mains		Pulse output, 5-6*.....	68
on/off.....	100	Pulse reference.....	5
supply.....	6	Q	
Voltage.....	18	Qualified personnel.....	11
Mechanical brake.....	47	Quick menu.....	14, 18, 19
Menu key.....	13, 18, 19	R	
Menu structure.....	19	Rated motor current.....	4
Minimum sleep time.....	115	Rated motor speed.....	4
Motor		RCD.....	6
High back EMF.....	158	Reference.....	18, 109
control principle.....	33	Relay configuration.....	63
current.....	18, 23, 37, 156	Relay output.....	61
data.....	21, 23, 154, 157	Reset.....	18, 19, 21, 154, 157
limit.....	54	Rotor resistance.....	38
magnetization at 0 speed.....	40	S	
pole.....	39	Safety.....	12
power.....	18, 156	Serial bus.....	149
rotating.....	158	Serial communication.....	4, 19
speed direction.....	54	Set-up operation, 0-1*.....	25
status.....	108	Short circuit.....	155
voltage.....	36	SLC.....	93
Overheating.....	154	Sleep mode.....	115
Warning.....	154	Sleep speed [Hz].....	116
N		Slip compensation.....	6
Navigation key.....	13, 18, 19	Smart logic control.....	93
Nominal motor speed.....	37	Start delay.....	41
NPN.....	57	Start/stop.....	9
Numeric display.....	13	Start-up.....	20
O		Stator leakage reactance.....	37, 38
Operating data.....	106	Stator resistance.....	38
Operating mode.....	24	Status menu.....	16
Operation key.....	13, 18	Synchronous motor speed.....	4
Output current.....	154	T	
Outputs		Terminal 42	
Analog output.....	5	Terminal 42 mode.....	73
P		Terminal 45	
Password.....	32	Terminal 45 mode.....	73
PELV.....	12		
Phase loss.....	154		
PNP.....	57		
Port diagnostics.....	83		

Terminal 53	
Terminal 53 filter time constant.....	72
Terminal 53 high current.....	71
Terminal 53 high voltage.....	71
Terminal 53 low current.....	71
Terminal 53 low voltage.....	71
Terminal 53 mode.....	72
Terminal 54	
Terminal 54 filter time constant.....	72
Terminal 54 high current.....	72
Terminal 54 high voltage.....	72
Terminal 54 low current.....	72
Terminal 54 low voltage.....	72
Terminal 54 mode.....	72
Terminals	
Control terminal.....	19
Input terminal.....	154
Thermal load.....	40, 109
Thermistor.....	6
Timer.....	95
Torque	
Limit.....	154
[%].....	109
Trip.....	6
Trip condition.....	149
Trip lock.....	149
U	
Unintended start.....	11, 102
V	
Voltage imbalance.....	154
VVC+.....	6
W	
Warning and alarm list.....	151
Warning current high.....	56
Warning current low.....	56



.....
Danfoss can accept no responsibility for possible errors in catalogues, brochures and other printed material. Danfoss reserves the right to alter its products without notice. This also applies to products already on order provided that such alterations can be made without subsequential changes being necessary in specifications already agreed. All trademarks in this material are property of the respective companies. Danfoss and the Danfoss logotype are trademarks of Danfoss A/S. All rights reserved.
.....

Danfoss A/S
Ulsnaes 1
DK-6300 Graasten
vlt-drives.danfoss.com

